



DANIEL WEEK 3



DANIEL

DANIEL WEEK 3

THE TREE

FOCUS

DANIEL 4:10-12, 16, 23, 31, 33-34 & 36

King Nebuchadnezzar has had another dream that troubled him! He asked Daniel what it meant, and Daniel told him. Even though Daniel warned the king to be humble before God, the king didn't listen! Now the king will suffer the consequences!

MATERIALS

Tree picture
King and Daniel actors and songs
Large tree with animals, fruit and branches
Tree coloring page (1 per child)
Consequences coloring page (1 per child)
Voice recording and speaker
Edible grass (1 handful per child)
Feathers and headband (1 per child)
Crayons, markers, tape and glue

ACTIVITIES

1. INTRODUCTION

TALK: Ask the children if they remember King Nebuchadnezzar and Daniel from week 1.

ACTIVITY: Show children the Tree picture and hang nearby for them to see.

2. ANOTHER DREAM

TALK: The king had a troubling dream and he wanted to know what it meant. He asked the wise men, and they could not tell him, so he asked Daniel. Daniel was able to tell him the dream and give him advice about what to do so the events in the dream would not happen.

ACTIVITY: Have king and Daniel sing the "I've had a dream" song.

CORRESPONDING VERSE

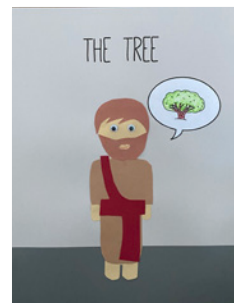

"THESE ARE THE VISIONS
I SAW WHILE LYING IN MY
BED: I LOOKED AND THERE
BEFORE ME STOOD A TREE."

DANIEL 4:10

ACTIVITIES

3. THE TREE

TALK: The king had a dream about a tree! The tree was huge! Animals lived underneath the leaves, birds flew from branch to branch and the tree had fruit for everyone!

ACTIVITY: Show children the large tree with the animals underneath and fruit on its branches. Then have children trace their hand in the shape of a tree then glue fruit and animals on it.

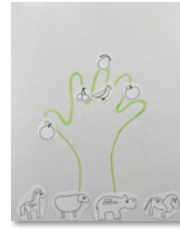

CORRESPONDING VERSE

"THE TREE GREW LARGE AND STRONG AND ITS TOP TOUCHED THE SKY... ITS FRUIT ABUNDANT."

DANIEL 4:11-12

4. CONSEQUENCES

TALK: The king liked the dream about the tree, until he heard a voice say to cut down the tree and trim off its branches! Daniel told him this meant he would be changed! He would have the mind of an animal and eat grass like an ox for 7 years! All the king had to do was to renounce his sins by doing what was right and to be kind to the oppressed. What would he choose?

ACTIVITY: Have children color the flip-up consequences page.

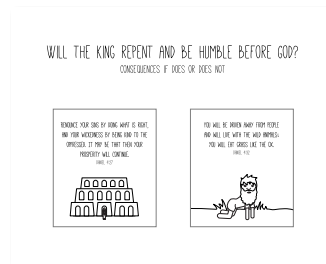

LET HIM BE DRENCHED WITH THE DEW OF HEAVEN, AND LET HIM LIVE WITH THE ANIMALS AMONG THE PLANTS OF THE EARTH. LET HIS MIND BE CHANGED FROM THAT OF A MAN AND LET HIM BE GIVEN THE MIND OF AN ANIMAL."

DANIEL 4:16

5. THE KING'S CHOICE

TALK: The king had a choice, he could either be kind and do what was right, and humble himself before God or he would have the mind of an animal for 7 years and eat grass like an ox! A year later the king was walking on the roof of his palace, saying about how great he was, and all of a sudden a voice from heaven told him that his royal authority was being taken away!

ACTIVITY: Have king stand before kids and talk about his amazing city, then play sound of the voice talking to the king, then have the king take off crown, get on all fours and run away.

YOUR ROYAL AUTHORITY HAS BEEN TAKEN FROM YOU.

DANIEL 4:31

6. IN TROUBLE

TALK: The king choose to not humble himself. He was proud of everything he had and did not thank God for everything he had given him. So everything he had dreamed about came true.

ACTIVITY: Have children take everything off the tree then take off the top of the tree, leaving a stump.

CUT DOWN THE TREE AND DESTROY IT, BUT LEAVE THE STUMP.

DANIEL 4:23

ACTIVITIES

7. EAT GRASS

TALK: Once the king had the mind of an animal he went into the wild and lived with the wild donkeys and ate grass like an ox!

ACTIVITY: Give each child a handful of edible grass to eat.



CORRESPONDING VERSE

ATE GRASS LIKE AN OX

DANIEL 4:33

8. HAIR LIKE AN EAGLE

TALK: The king lived in the wild and his hair grew like the feathers of an eagle!

ACTIVITY: Have each child make a headband with feathers.



HIS HAIR GREW LIKE THE FEATHERS OF AN EAGLE.

DANIEL 4:33

9. BACK AGAIN

TALK: Just like the voice and Daniel had said, at the end of 7 years the king looked up to heaven and his sanity was restored. Do you think he was mad that he had spent 7 years living like an animal? No! He praised God! He even sent out a letter to everyone in his kingdom to hear what God had done to him!

ACTIVITY: Have king take off headband then put on crown and heart necklace then look up to heaven and say:

KING: I have eaten grass! I have lived with wild donkeys for 7 years! I am alive! You Lord, are mighty. You are awesome to behold. Not me!



AT THE END OF THAT TIME, I ... RAISED MY EYES TOWARD HEAVEN, AND MY SANITY WAS RESTORED. THEN I PRAISED THE MOST HIGH

DANIEL 4:34

10. RESTORED

TALK: God restored the king to his throne and he became even greater than before! God was able to humble the king and show him that He was the greatest of all!

ACTIVITY: Have kids put the tree back together then tape hearts on the tree.



I WAS RESTORED TO MY THRONE AND BECAME EVEN GREATER THAN BEFORE.

DANIEL 4:36

OPTIONAL: Hand out each child a bible verse to take home.

AND THOSE WHO
WALK IN PRIDE
HE IS ABLE TO HUMBLE.

DANIEL 4:37

THE TREE

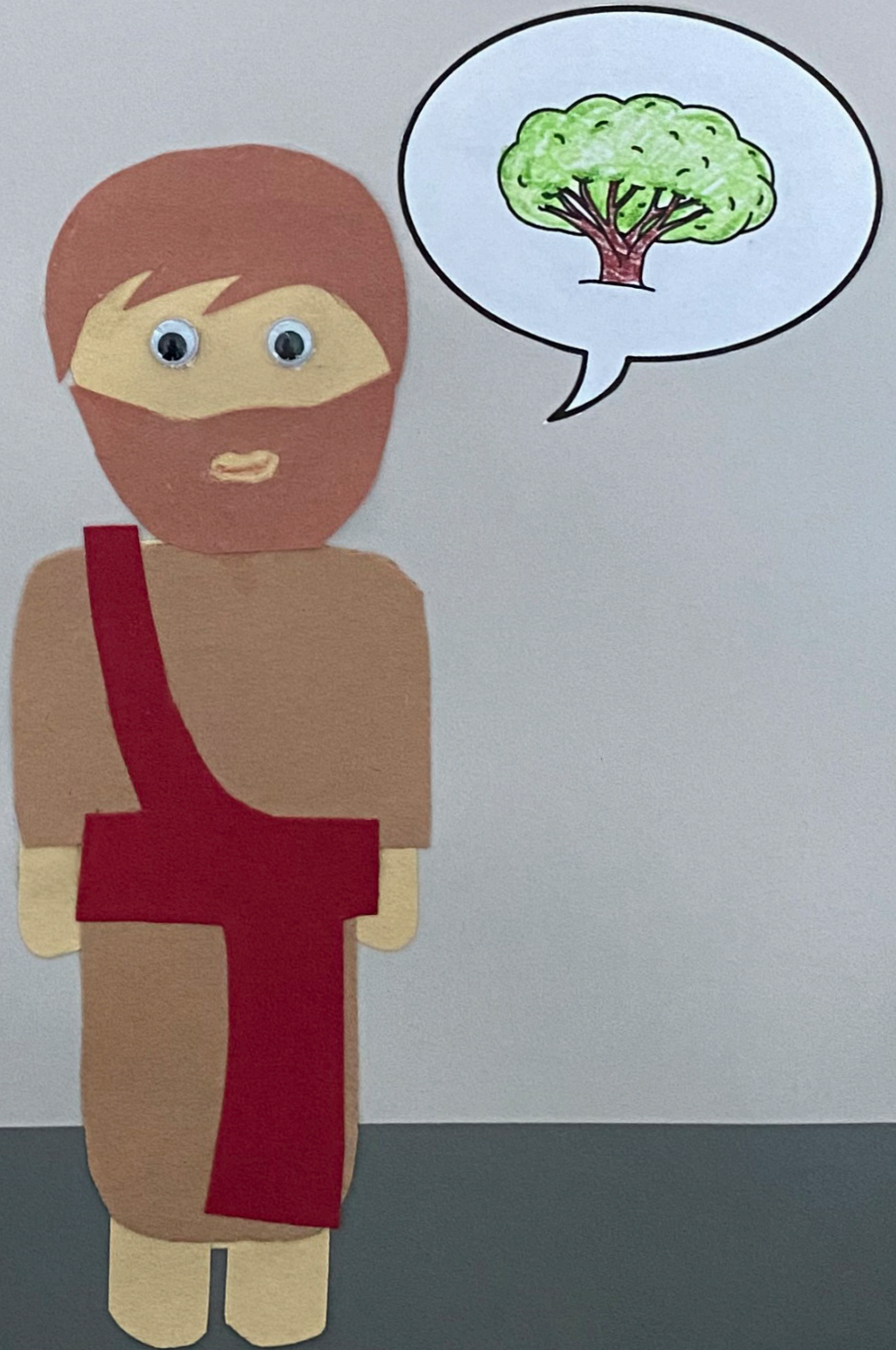

I'VE HAD A DREAM

KING: I'VE HAD A DREAM! I'VE HAD A DREAM, NOW DANIEL,
TELL ME WHAT IS MEANS! WHAT IT MEANS!

DANIEL: YOU ARE A TREE OH KING, MIGHTY AND STRONG.
WITH FRUIT TO SPARE AND BRANCHES SO LONG. BUT
BE SURE TO TELL THE GOD ABOVE THANKS! OR HE
WILL CUT YOU DOWN WITH A BIG BIG THWANK. WITH
A BIG BIG THWANK.

TREE

1 1/4" CROSS (1)

1" CROSS (1)

3/4" CROSS (1)
NOT PICTURED

1 1/4" TEE (5)

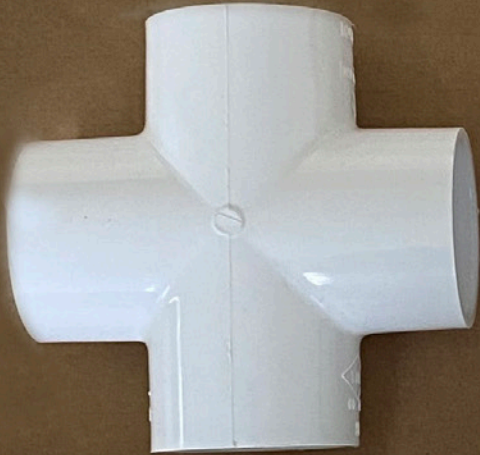

1 1/4" 2'
PVC PIPE (5)



1 1/4"
45*
ELBOW (6)



1" 2' PVC
PIPE (3)



1" 45*
ELBOW (2)



1" TEE (2)



3/4" 2' PVC PIPE (2)

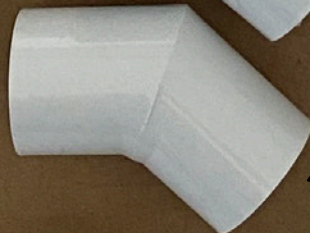

3/4" 45*
ELBOW (2)



3/4" TEE (2)



1 1/4" END
CAPS (8)



1" END
CAPS (4)



3/4" END
CAPS (5)



1-3/4"
REDUCER (1)



1 1/4-1"
REDUCER (1)

TREE

1 1/4" 2' PVC PIPE (5)

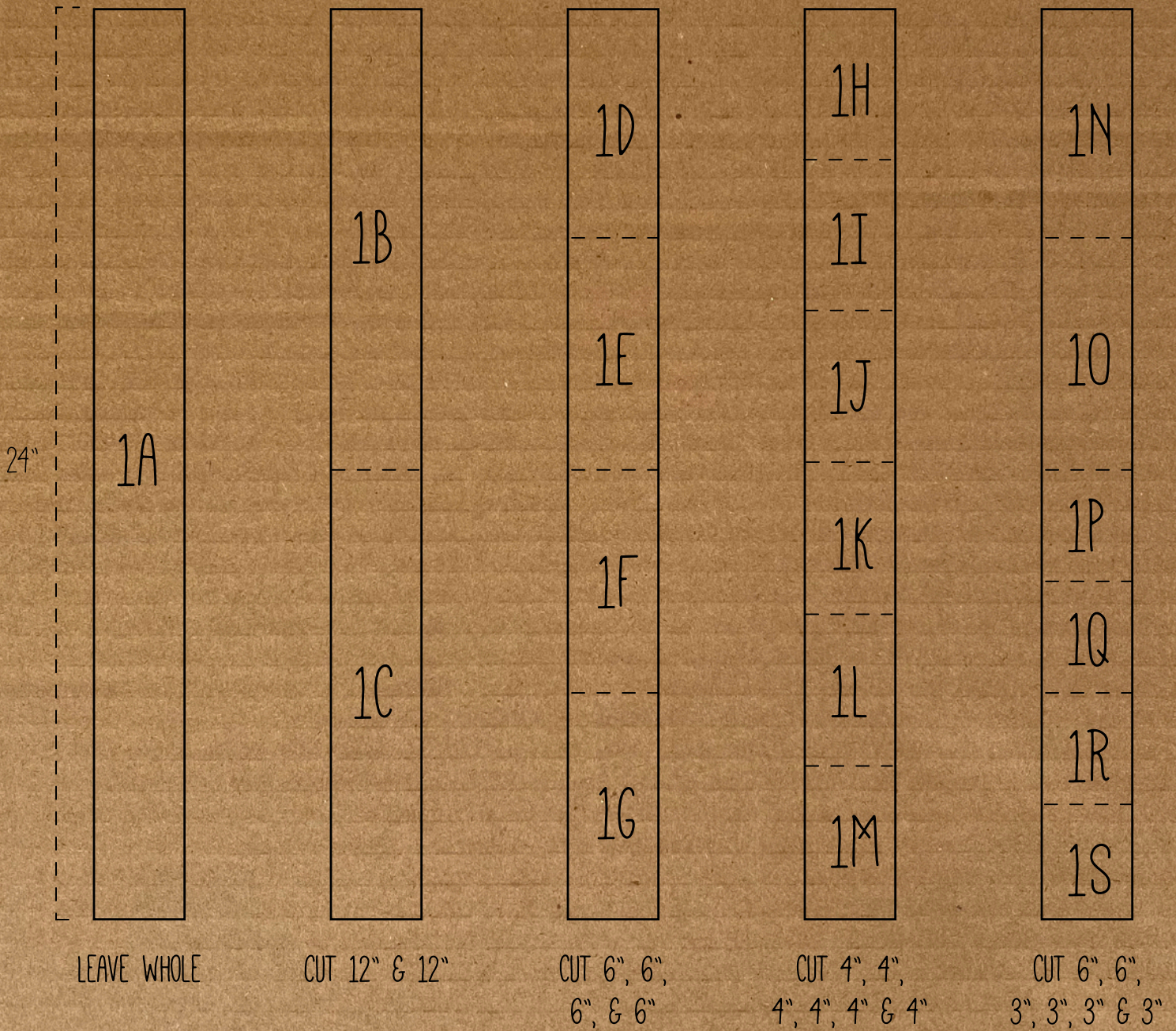

TREE

1" 2' PVC PIPE (3)

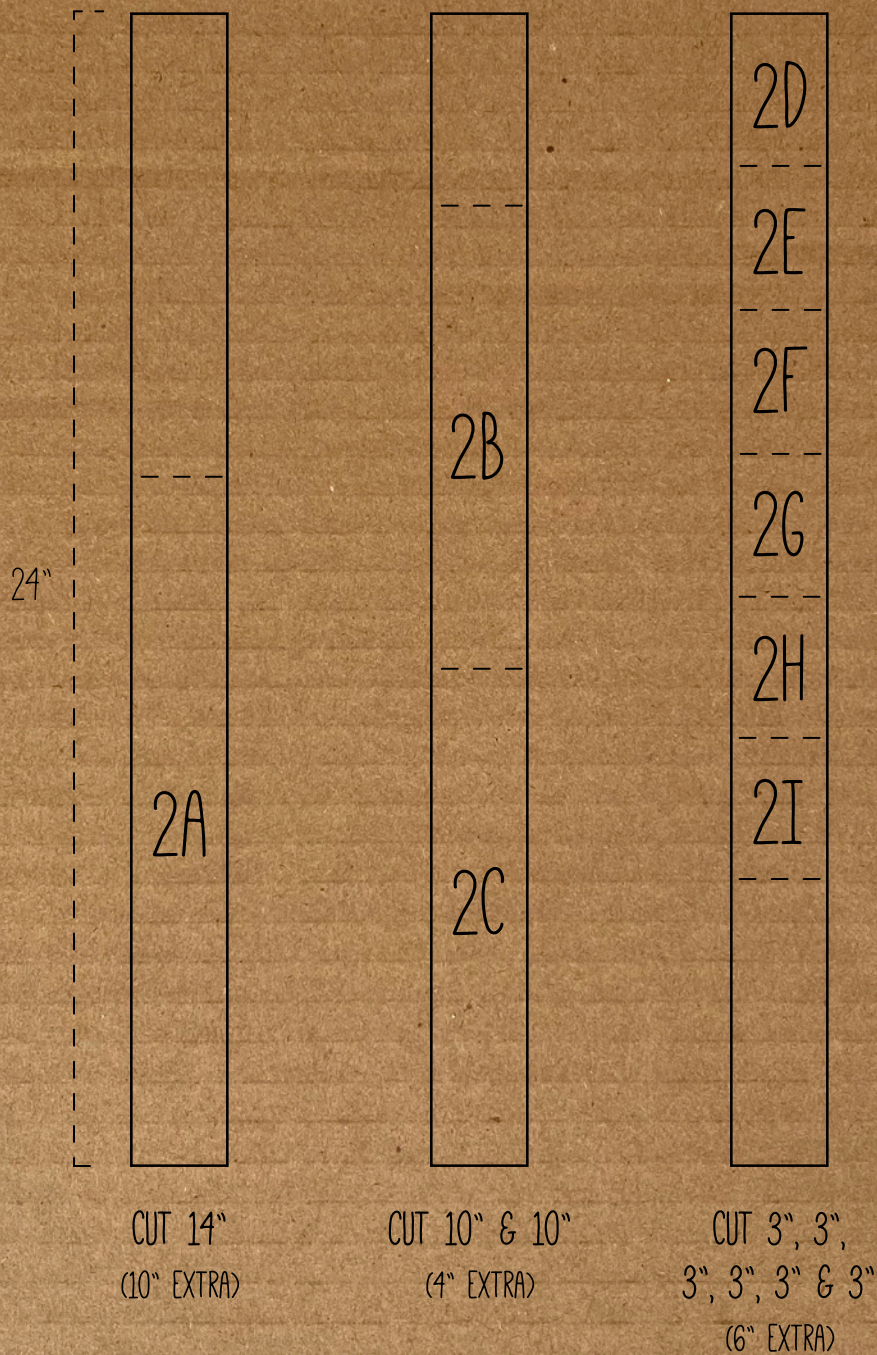

TREE

3/4" 2' PVC PIPE (2)

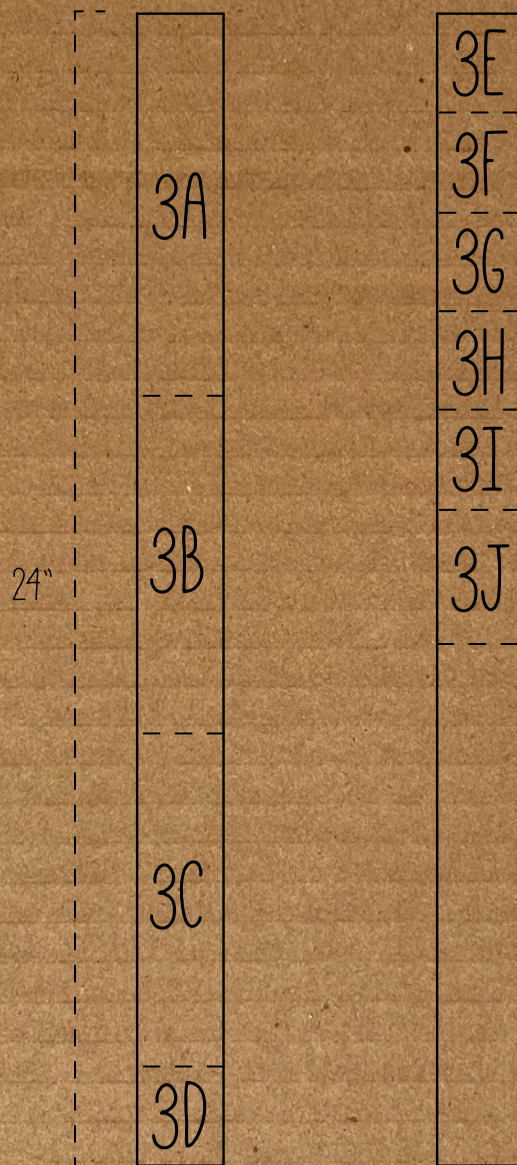

CUT 8"
7", 7" & 2"

CUT 2", 2"
2", 2", 2" & 3"
(11" EXTRA)

TREE

ROOTS (BASE)

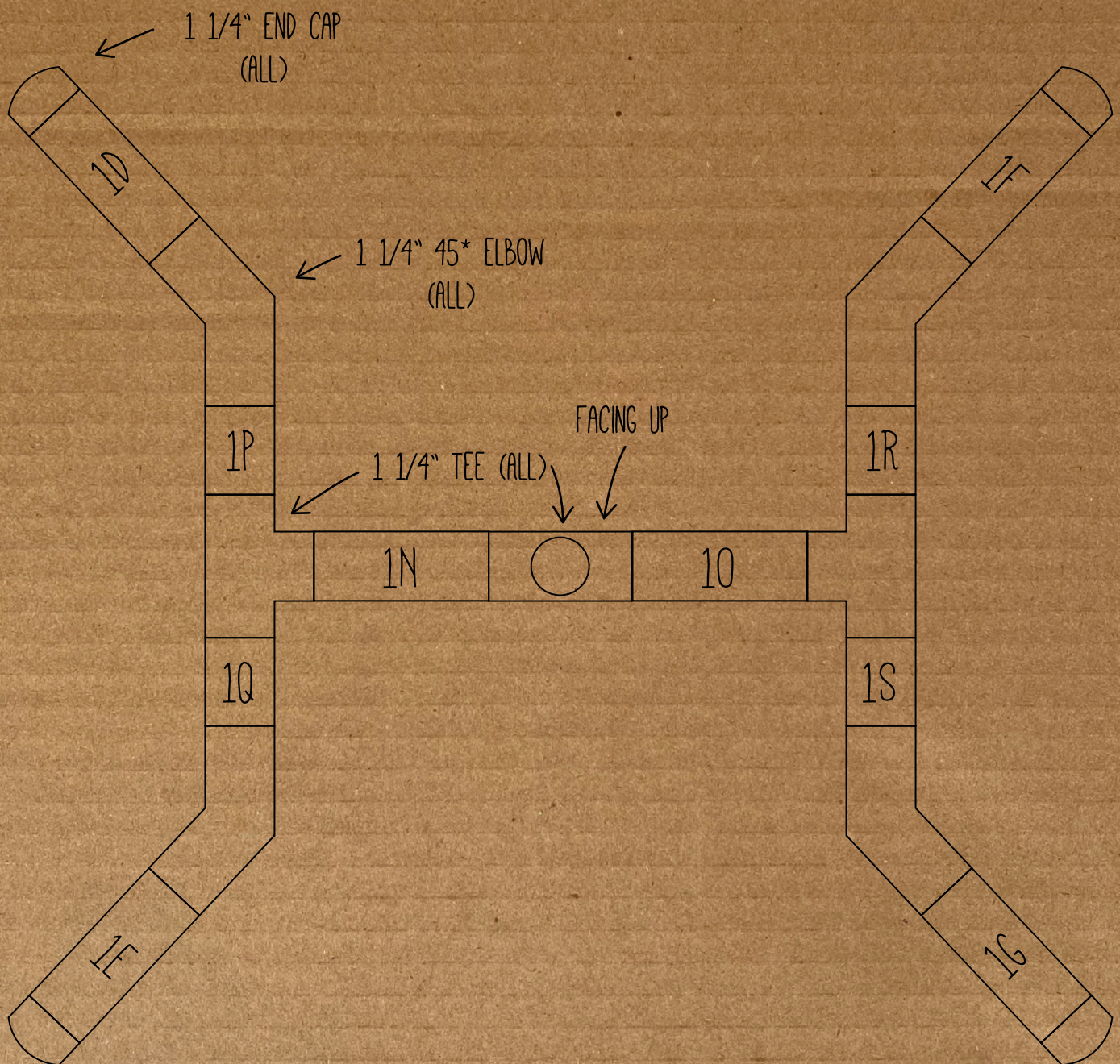

TREE

TRUNK (CONNECTED TO ROOTS)



TREE

LOWER BRANCHES (CONNECTED TO TRUNK)

LEFT SIDE SHOWN, REPEAT FOR RIGHT SIDE

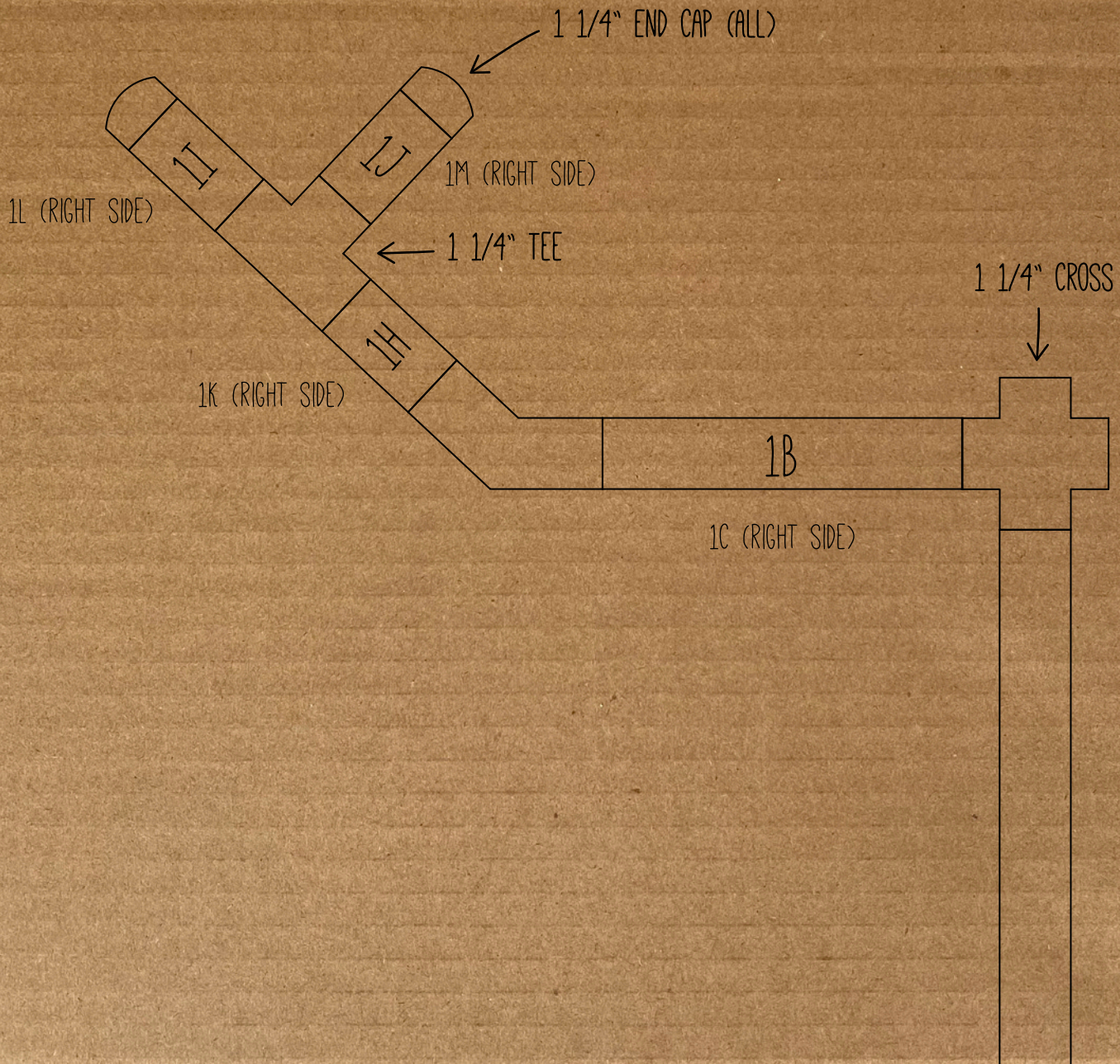

TREE

MIDDLE TRUNK (CONNECTED TO TRUNK)

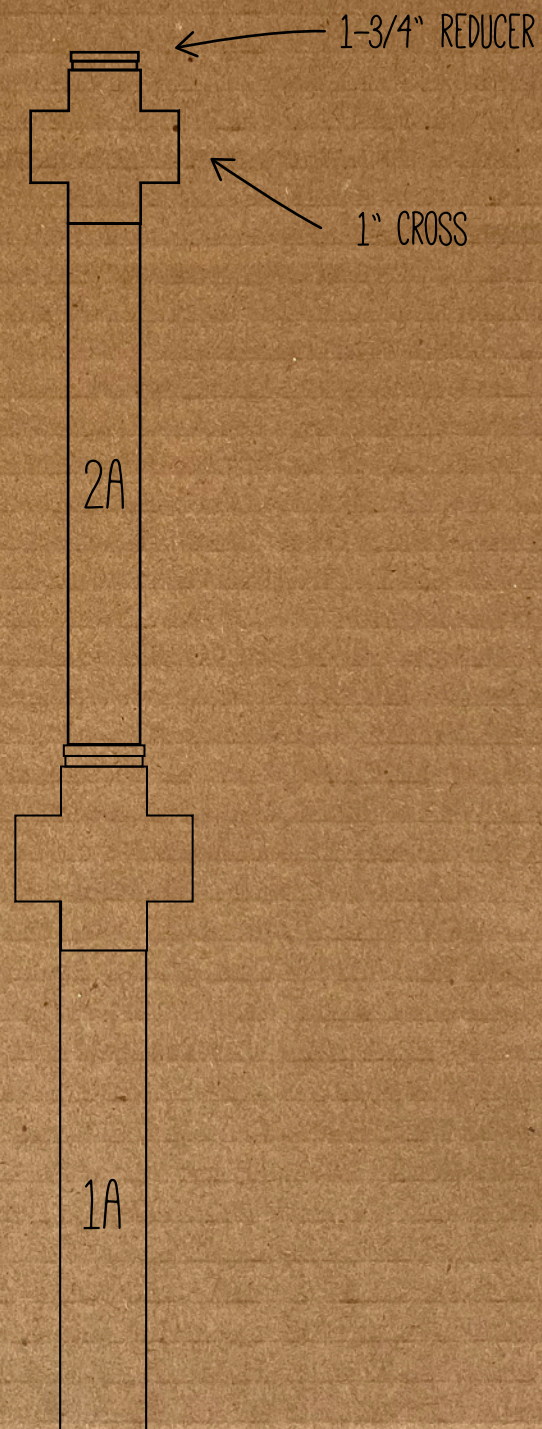

TREE

MIDDLE BRANCHES (CONNECTED TO MIDDLE TRUNK)

LEFT SIDE SHOWN, REPEAT FOR RIGHT SIDE

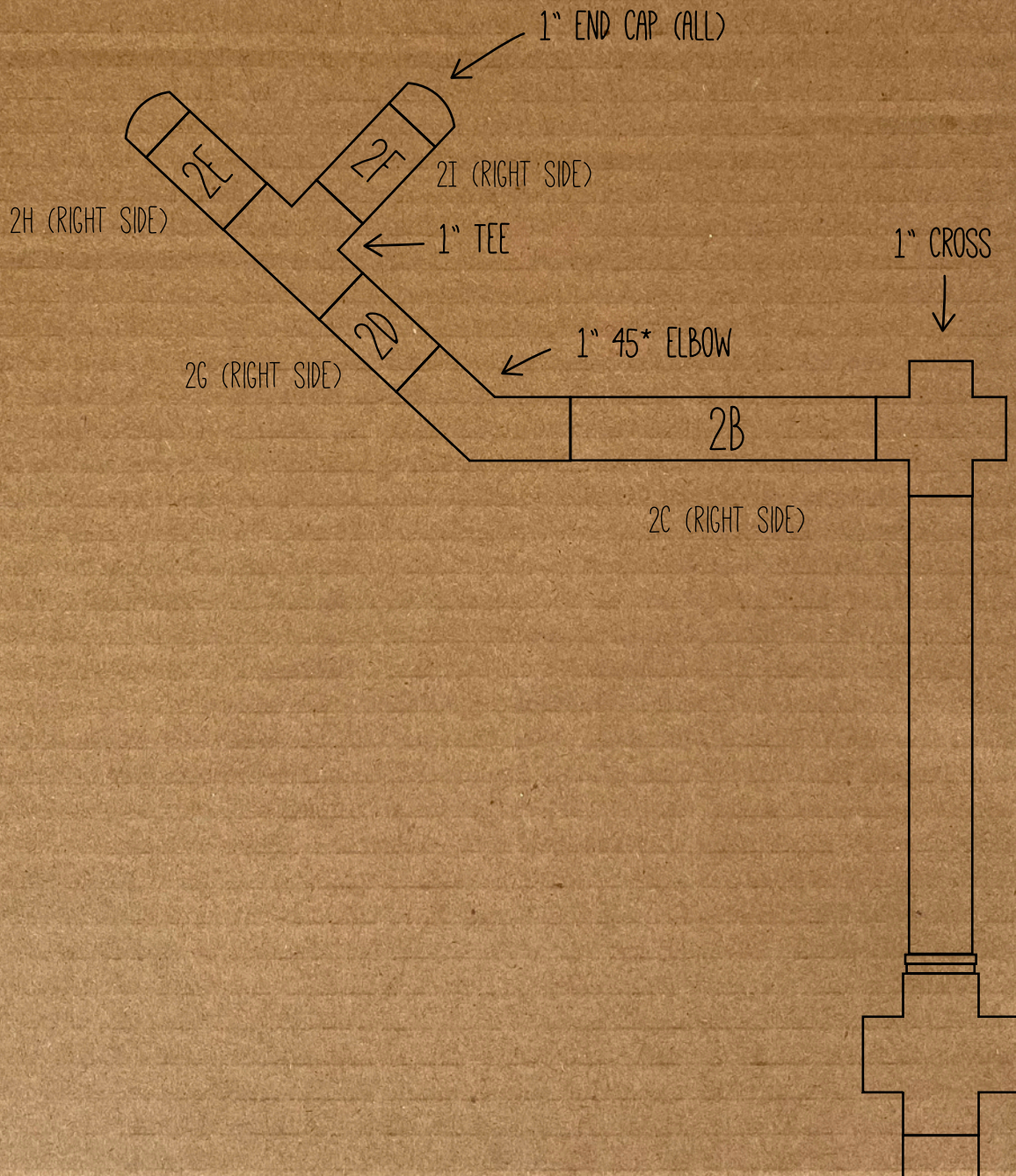

TREE

UPPER BRANCHES (CONNECTED TO UPPER TRUNK)

LEFT SIDE SHOWN, REPEAT FOR RIGHT SIDE

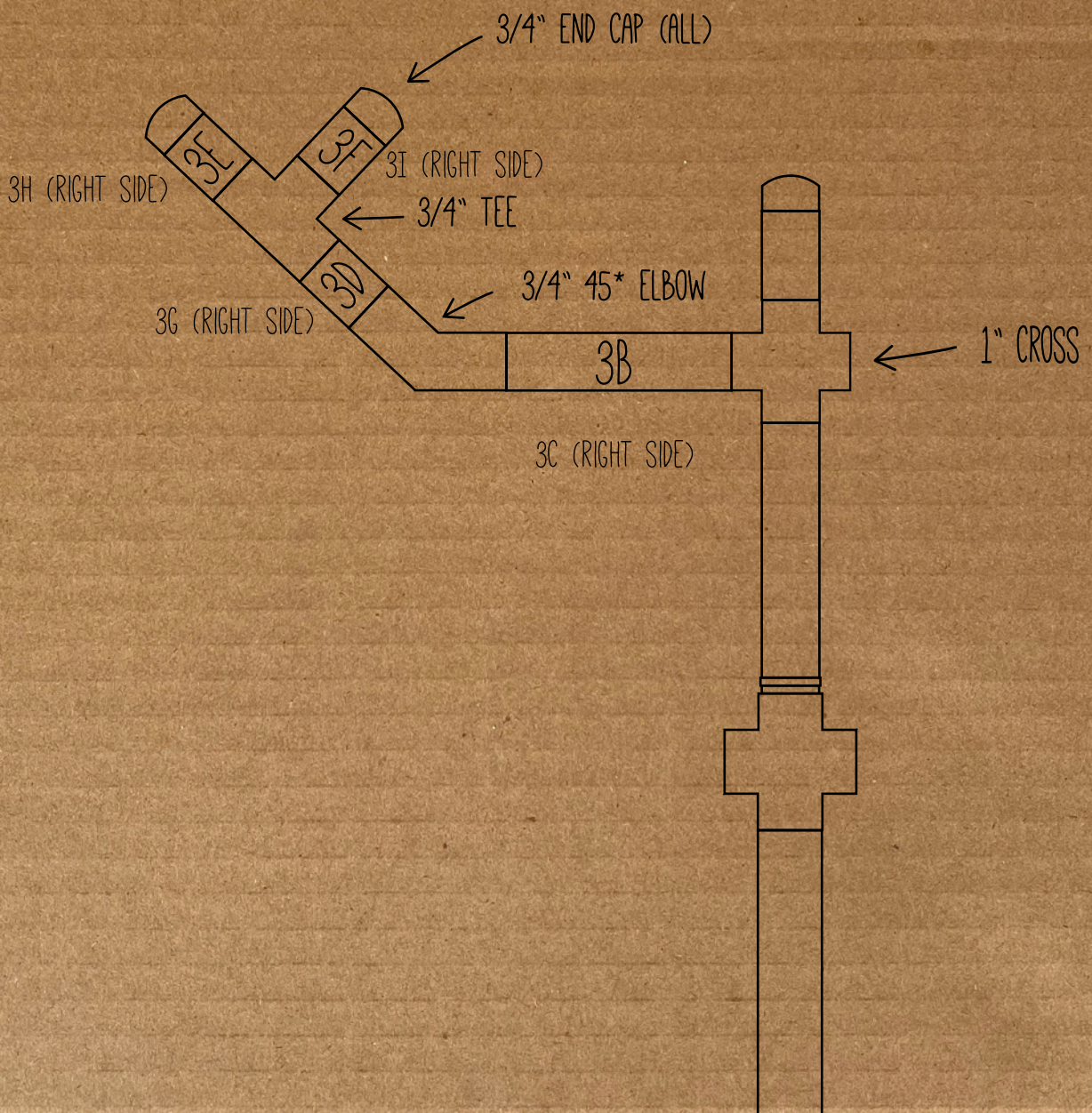

TREE

UPPER TRUNK (CONNECTED TO MIDDLE TRUNK)

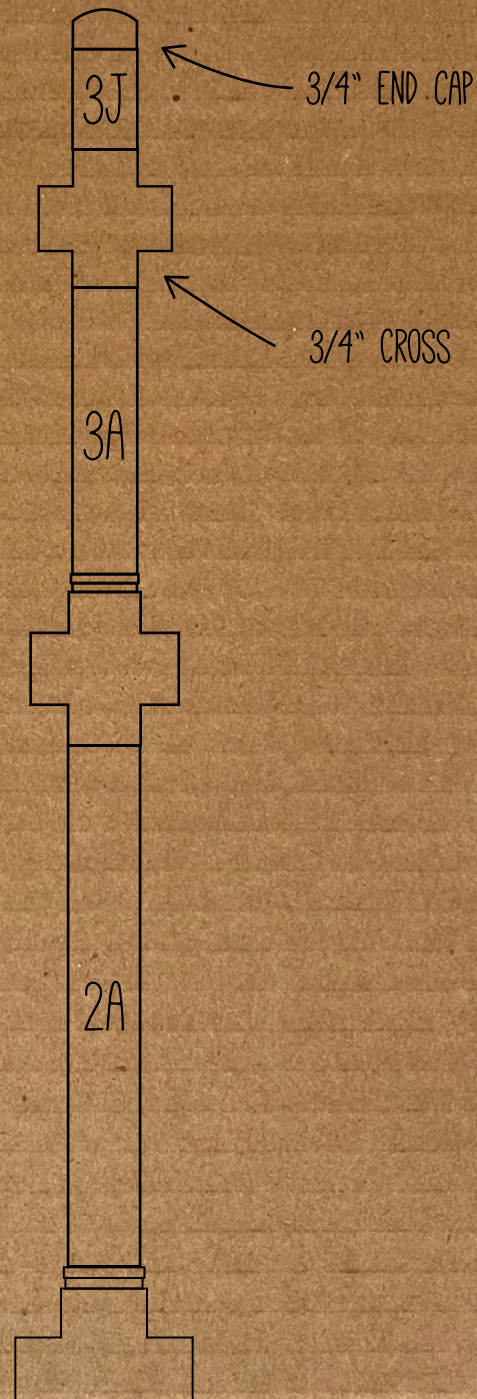

TREE

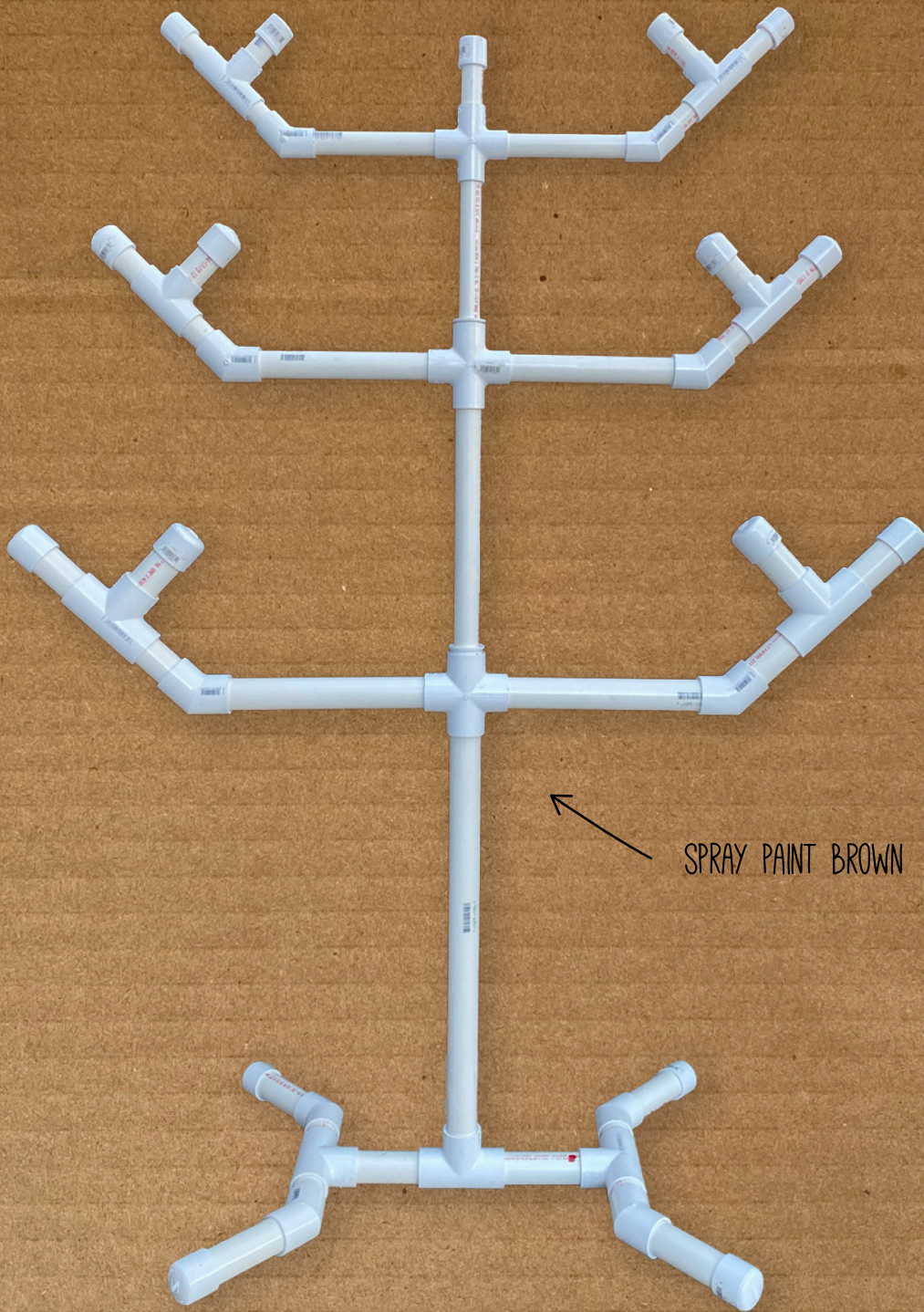

SPRAY PAINT BROWN

TREE BRANCH

GREEN CONSTRUCTION PAPER

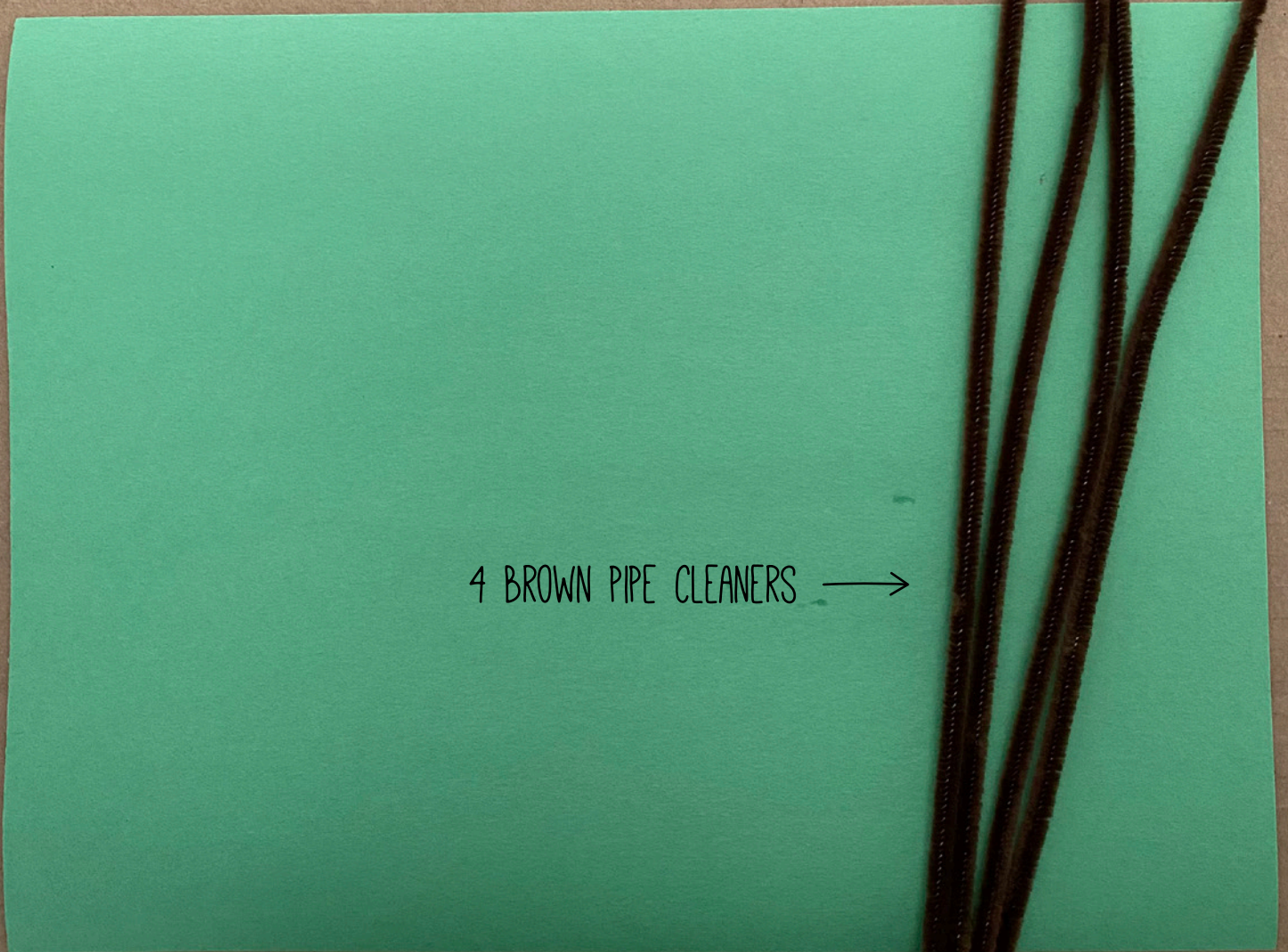
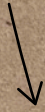

4 BROWN PIPE CLEANERS →



TREE BRANCH

CUT THREE VARIOUS SIZE LEAVES PER BRANCH



MAKE 2 HOLE PUNCH
HOLES AT ONE END

TREE BRANCH

TWIST 2 PIPE CLEANERS
TOGETHER FOR EXTRA
STRENGTH. MAKING SURE THEY →
ARE SECURE ON BOTH ENDS
SO THEY WILL NOT UNRAVEL.

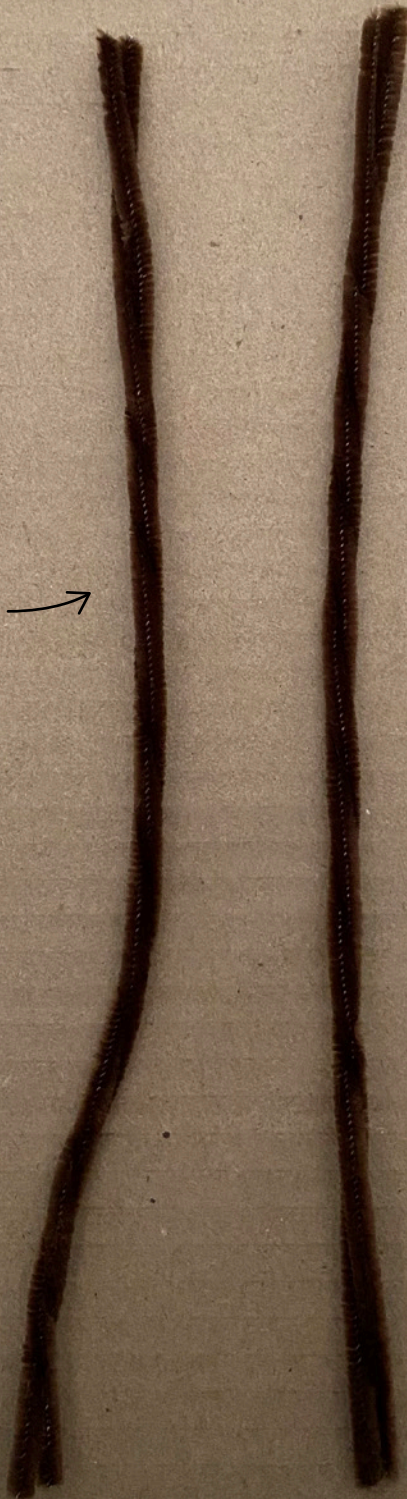

TREE BRANCH

TWIST 2 PIPE CLEANERS
TOGETHER SECURELY TO
MAKE THREE BRANCHES

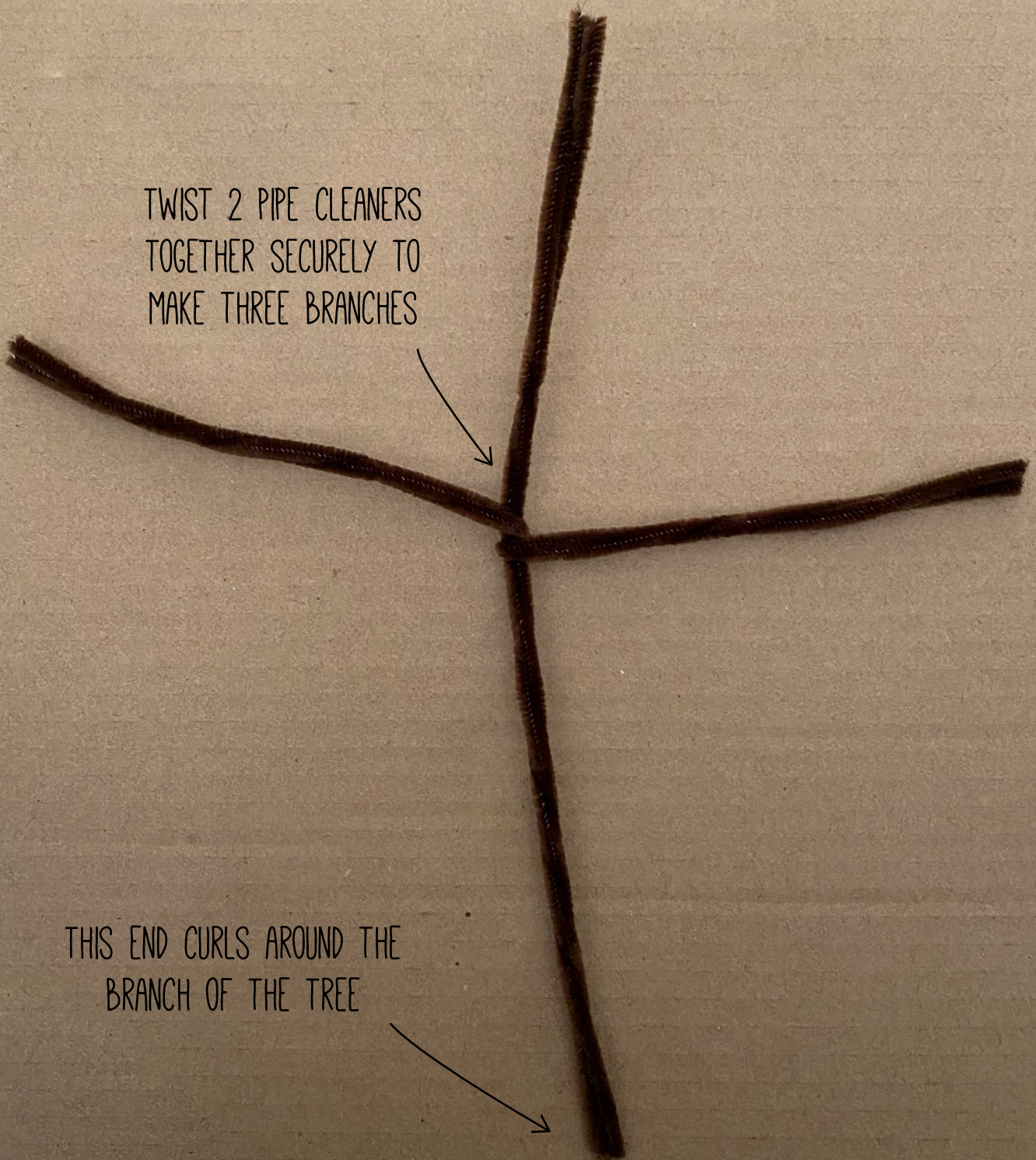

THIS END CURLS AROUND THE
BRANCH OF THE TREE

TREE BRANCH

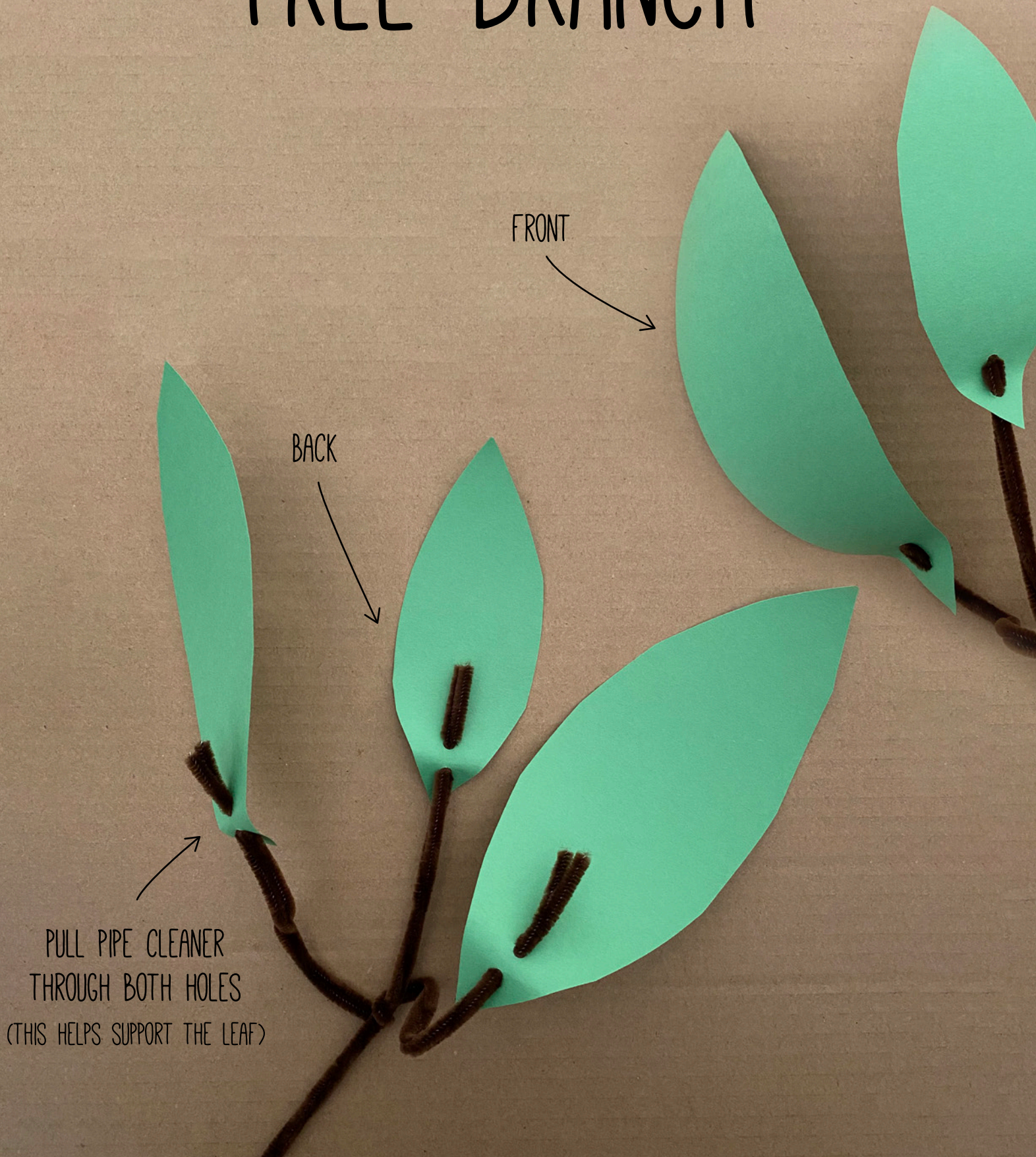

FRONT

BACK

PULL PIPE CLEANER
THROUGH BOTH HOLES
(THIS HELPS SUPPORT THE LEAF)

FRUIT

CUT OUT A STEM SHAPE



CUT OUT A LEAF SHAPE

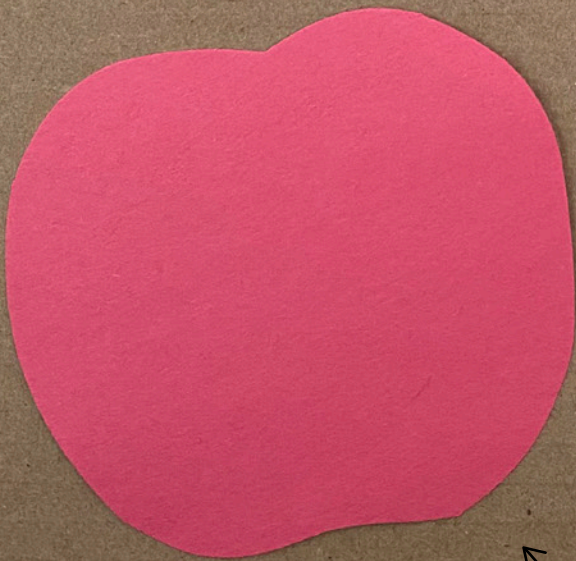

CUT OUT AN APPLE SHAPE



CUT 1 PIECE OF
BROWN PIPE CLEANER
IN HALF

FRUIT

CUT A SMALL HOLE WITH A HOLE PUNCH

GLUE STEM ON APPLE

GLUE LEAF ON TOP OF STEM

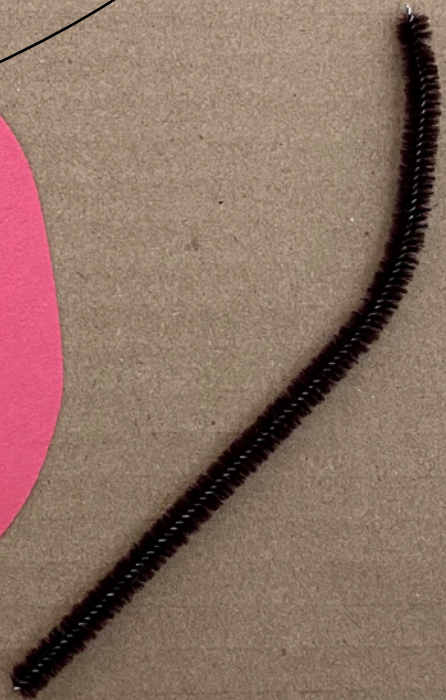
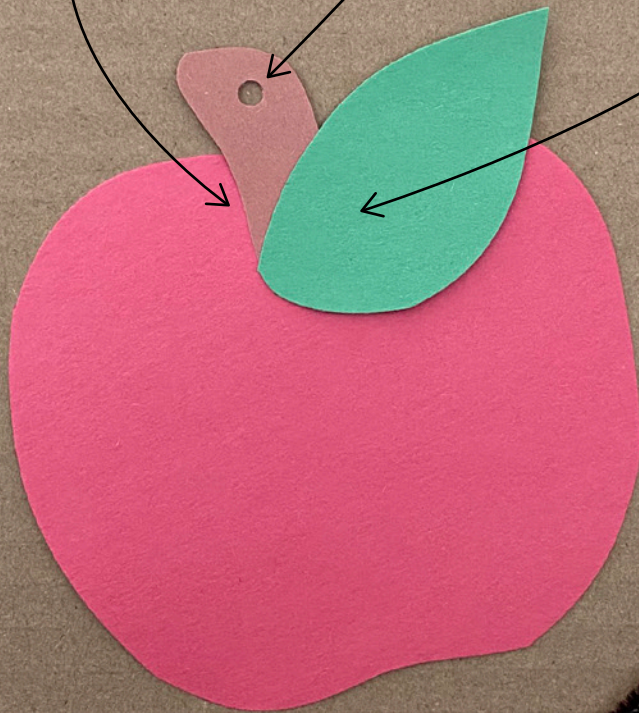

FRUIT

CURVE PIPE CLEANER
TO FORM A HOOK

PLACE PIPE CLEANER THROUGH HOLE
AND TWIST TOGETHER

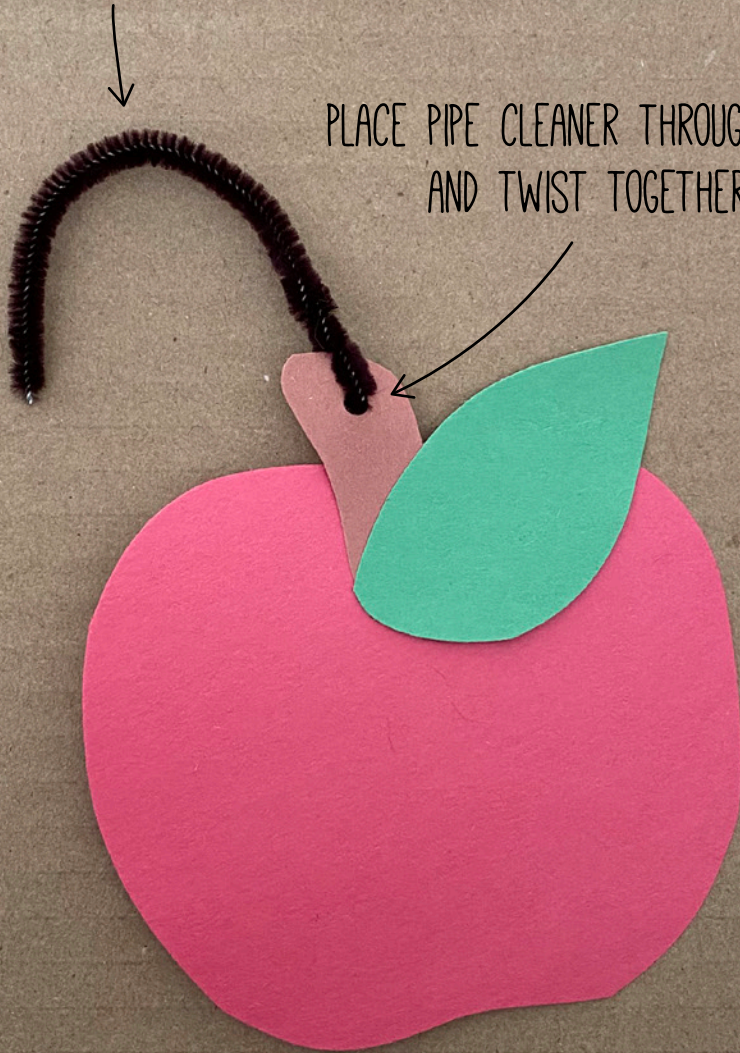

"HAND" TREE

TRACE OUTLINE OF CHILD'S HAND & ARM

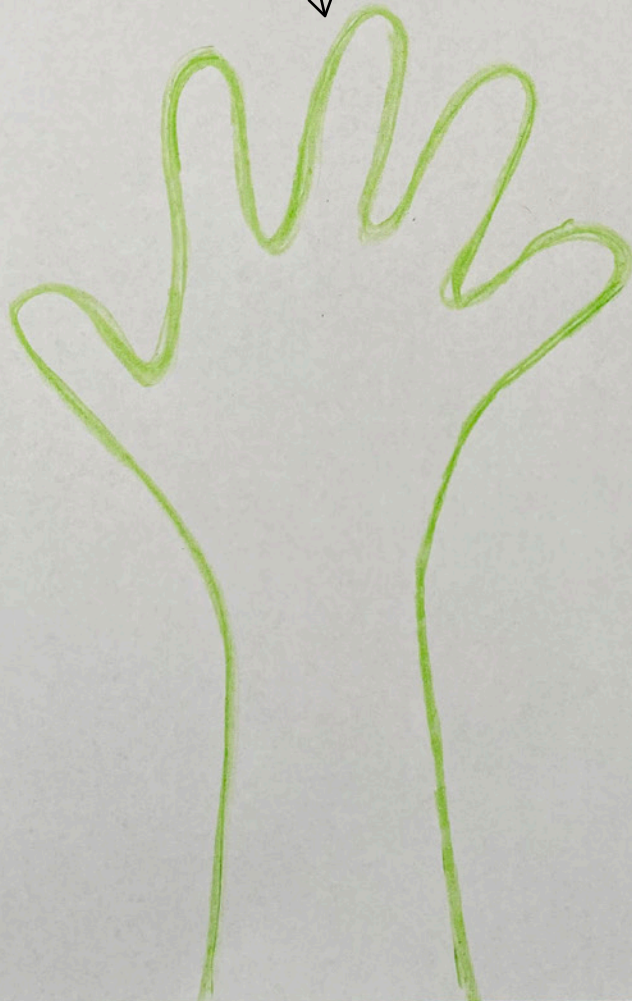

PRECUT

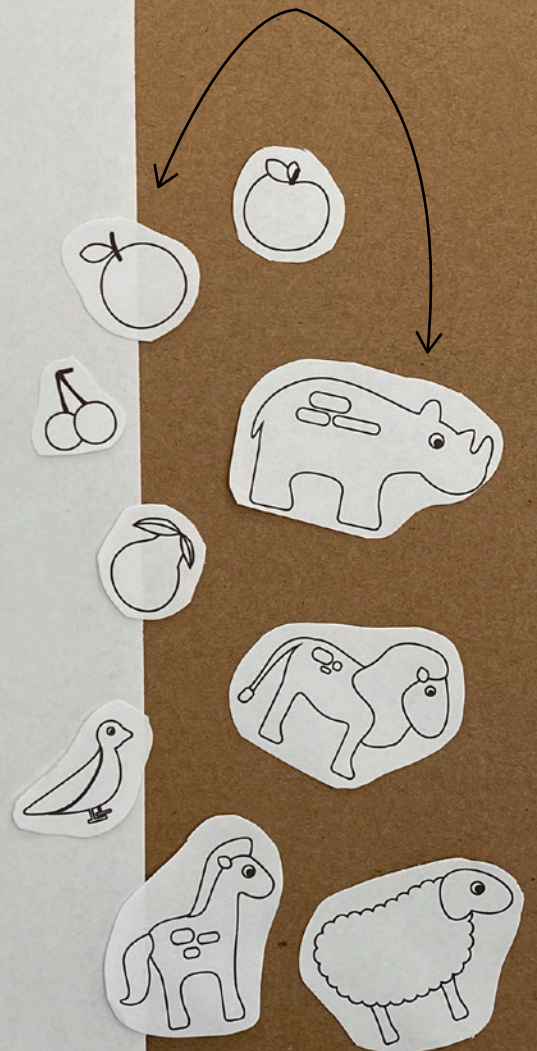

"HAND" TREE

GLUE FRUIT & BIRDS IN THE BRANCHES

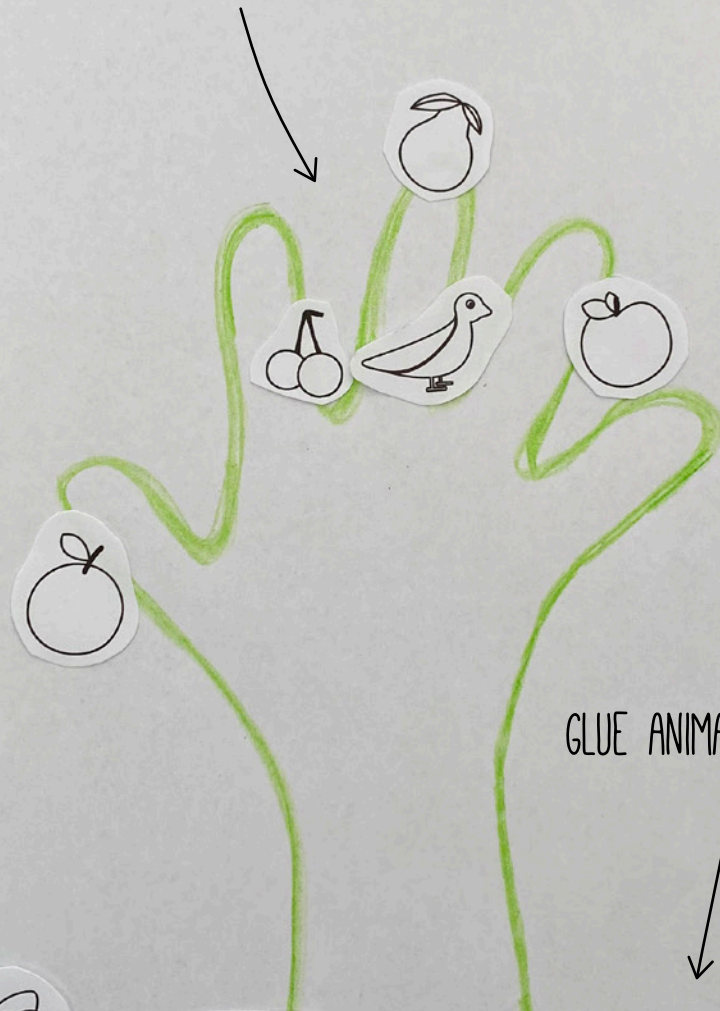

GLUE ANIMALS AT BOTTOM



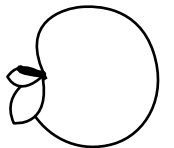
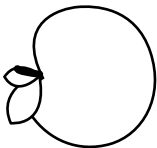
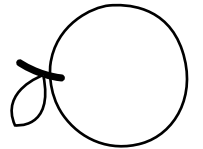
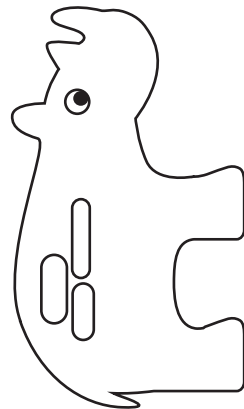
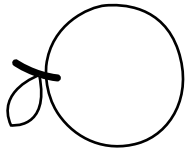
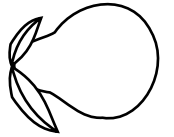
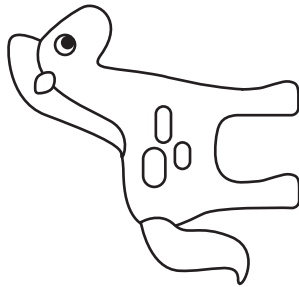
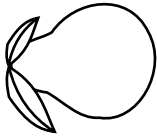
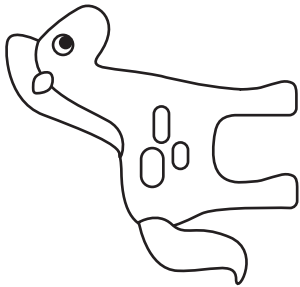
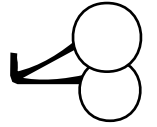
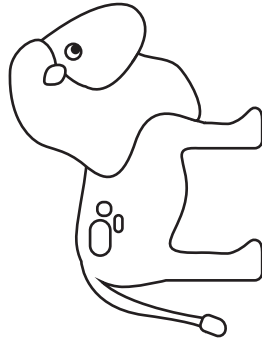
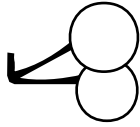
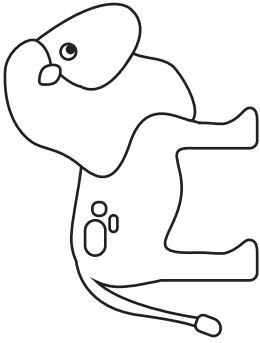
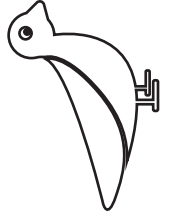
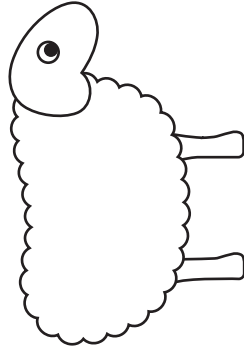
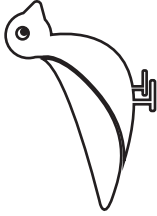
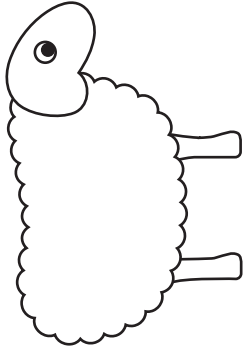

CONSEQUENCES

PRINT



PRINT & CUT

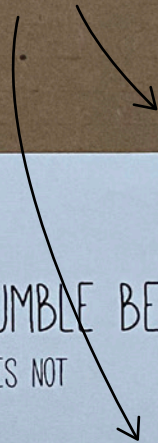

WILL THE KING REPENT AND BE HUMBLE BEFORE
CONSEQUENCES IF DOES OR DOES NOT

RENOUNCE YOUR SINS BY DOING WHAT IS RIGHT,
AND YOUR WICKEDNESS BY BEING KIND TO THE
OPPRESSED. IT MAY BE THAT THEN YOUR
PROSPERITY WILL CONTINUE.
DANIEL 4:27

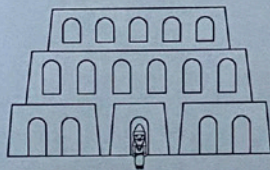

YOU WILL BE DRIVEN AWAY
AND WILL LIVE WITH THE WILD ANIMALS.
YOU WILL EAT GRASS LIKE
DANIEL 4:32



DOES

DOES NOT

CONSEQUENCES

TAPE ON TOP

WILL THE KING REPENT AND BE HUMBLE BEFORE GOD?
CONSEQUENCES IF DOES OR DOES NOT

DOES

DOES NOT

DOES

DOES NOT

WILL THE KING REPENT AND BE HUMBLE BEFORE GOD?

CONSEQUENCES IF DOES OR DOES NOT

RENOUNCE YOUR SINS BY DOING WHAT IS RIGHT,
AND YOUR WICKEDNESS BY BEING KIND TO THE
OPPRESSED. IT MAY BE THAT THEN YOUR
PROSPERITY WILL CONTINUE.

DANIEL 4:27

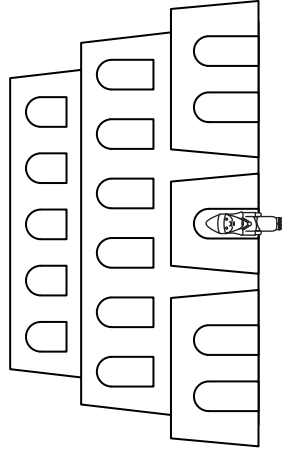

YOU WILL BE DRIVEN AWAY FROM PEOPLE
AND WILL LIVE WITH THE WILD ANIMALS;
YOU WILL EAT GRASS LIKE THE OX.

DANIEL 4:32

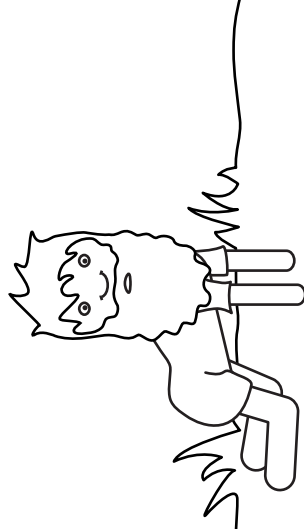

This is what is decreed for you, King Nebuchadnezzar: Your royal authority has been taken from you. You will be driven away from people and will live with the wild animals; you will eat grass like the ox. Seven times will pass by for you until you acknowledge that the Most High is sovereign over all kingdoms on earth and gives them to anyone he wishes.

EDIBLE GRASS

1. Turn oven on to 350* for 10 minutes.
2. Mix 2 cups of sweetened shredded coconut with 4 tsp of spinach puree.
3. Turn oven off and bake for at least 10 minutes, stirring the coconut every few minutes.



FEATHER HAT

BUNCH OF COLORED FEATHERS



2 LONG STRIPS OF PAPER →



FEATHER HAT

PLACE FEATHERS IN A ROW AND
TAPE ON WITH A LONG STRIP OF TAPE



GLUE AND TAPE THE TWO STRIPS OF PAPER TOGETHER TO FORM ONE LONG STRIP.
AFTER TAPING ON THE FEATHERS, TAPE OTHER ENDS OF THE STRIPS TOGETHER
TO FIT CHILD AND FORM A HEADBAND.

HUMBLE HEART

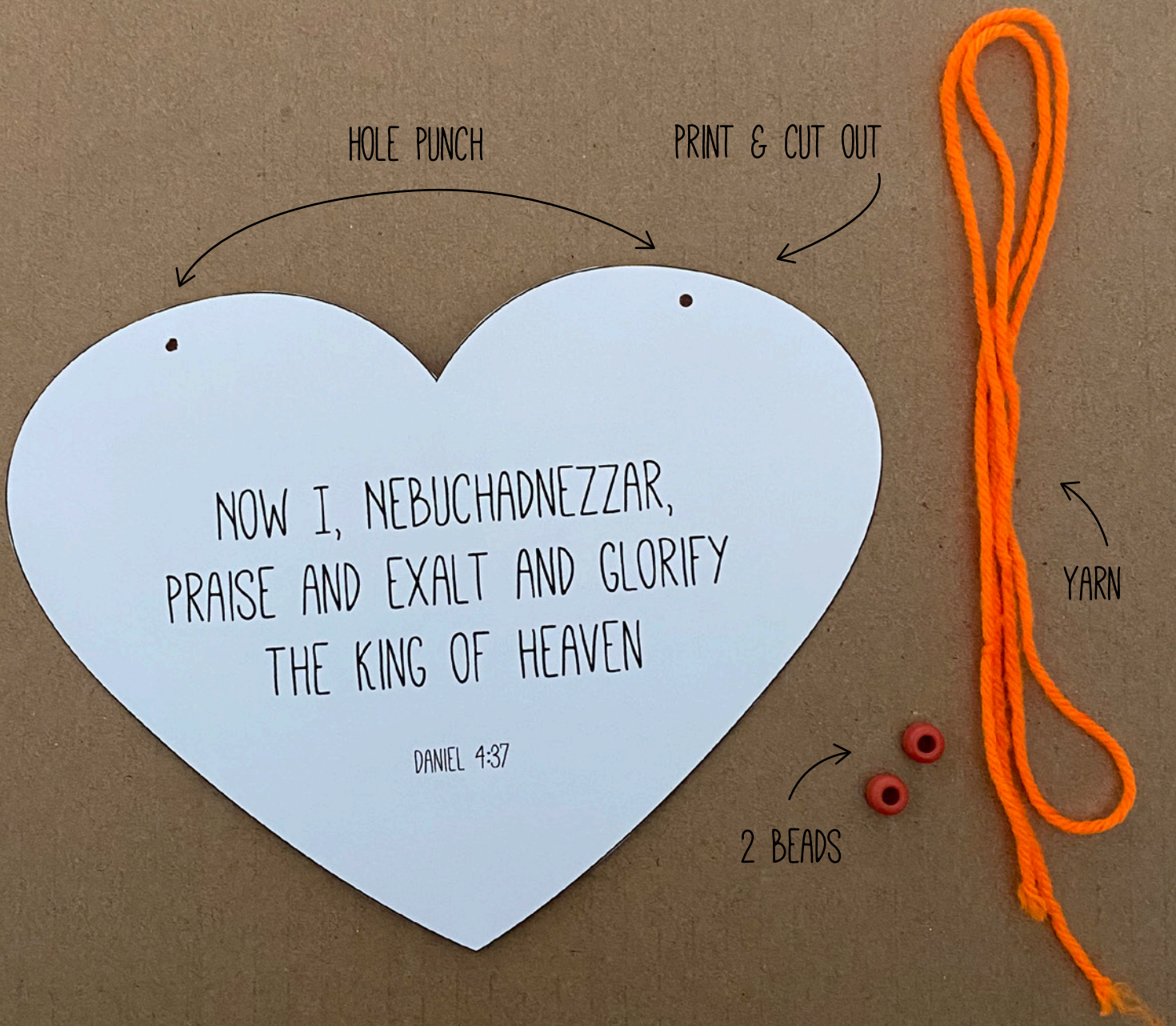

HUMBLE HEART

LACE YARN THROUGH HOLE PUNCH
AND PLACE BEAD THROUGH HOLE
ON BACK SIDE OF HEART

TIE BEAD SECURELY

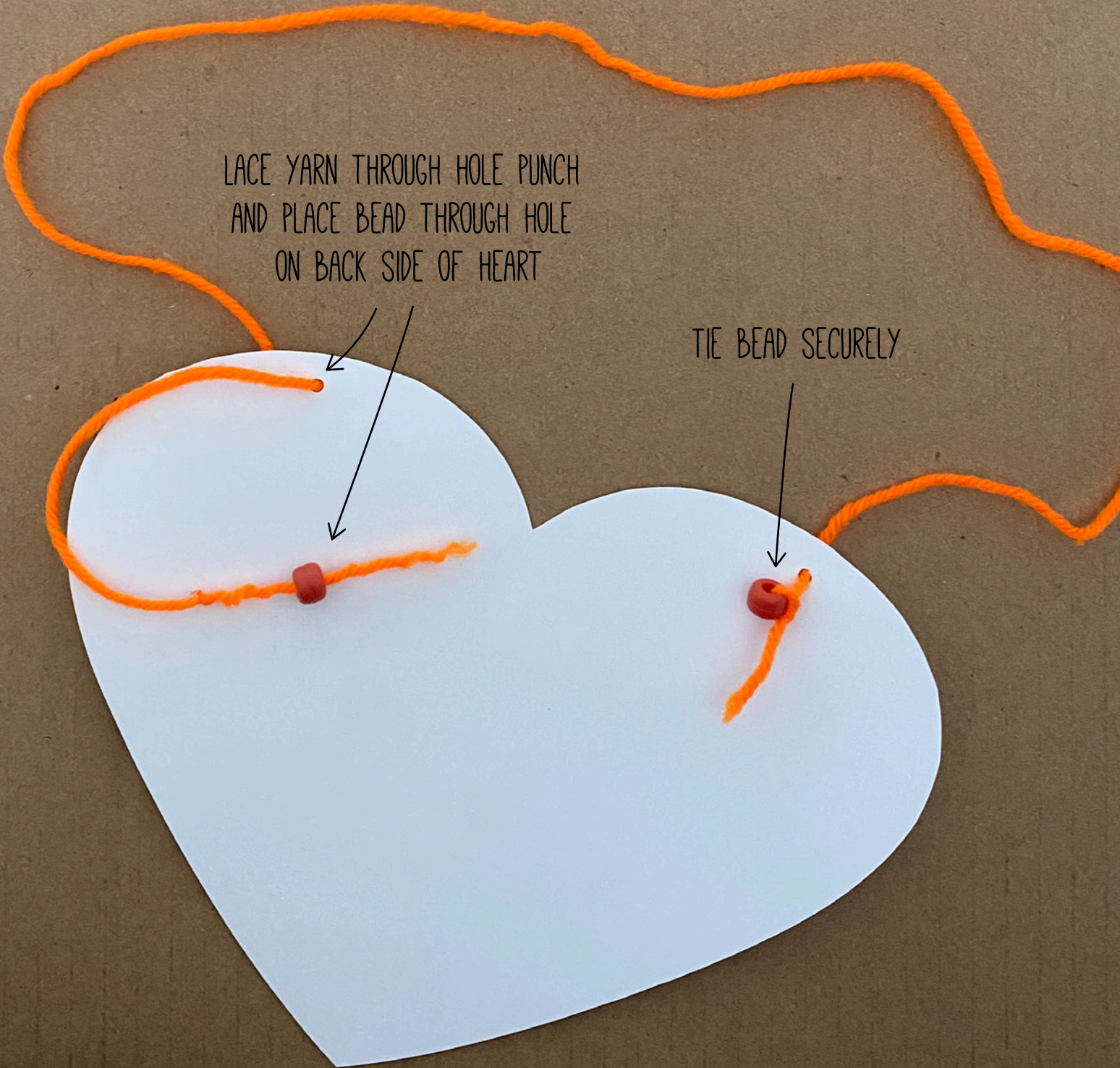

NOW I, NEBUCHADNEZZAR,
PRAISE AND EXALT AND GLORIFY
THE KING OF HEAVEN

DANIEL 4:37

NOW I, NEBUCHADNEZZAR, PRAISE
AND EXALT AND GLORIFY THE
KING OF HEAVEN

DANIEL 4:37

NOW I, NEBUCHADNEZZAR, PRAISE
AND EXALT AND GLORIFY THE
KING OF HEAVEN

DANIEL 4:37

NOW I, NEBUCHADNEZZAR, PRAISE
AND EXALT AND GLORIFY THE
KING OF HEAVEN

DANIEL 4:37

NOW I, NEBUCHADNEZZAR, PRAISE
AND EXALT AND GLORIFY THE
KING OF HEAVEN

DANIEL 4:37

NOW I, NEBUCHADNEZZAR, PRAISE
AND EXALT AND GLORIFY THE
KING OF HEAVEN

DANIEL 4:37

NOW I, NEBUCHADNEZZAR, PRAISE
AND EXALT AND GLORIFY THE
KING OF HEAVEN

DANIEL 4:37

NOW I, NEBUCHADNEZZAR, PRAISE
AND EXALT AND GLORIFY THE
KING OF HEAVEN

DANIEL 4:37

NOW I, NEBUCHADNEZZAR, PRAISE
AND EXALT AND GLORIFY THE
KING OF HEAVEN

DANIEL 4:37

NOW I, NEBUCHADNEZZAR, PRAISE
AND EXALT AND GLORIFY THE
KING OF HEAVEN

DANIEL 4:37

NOW I, NEBUCHADNEZZAR, PRAISE
AND EXALT AND GLORIFY THE
KING OF HEAVEN

DANIEL 4:37

NOW I, NEBUCHADNEZZAR, PRAISE
AND EXALT AND GLORIFY THE
KING OF HEAVEN

DANIEL 4:37

NOW I, NEBUCHADNEZZAR, PRAISE
AND EXALT AND GLORIFY THE
KING OF HEAVEN

DANIEL 4:37

NOW I, NEBUCHADNEZZAR, PRAISE
AND EXALT AND GLORIFY THE
KING OF HEAVEN

DANIEL 4:37

NOW I, NEBUCHADNEZZAR, PRAISE
AND EXALT AND GLORIFY THE
KING OF HEAVEN

DANIEL 4:37

NOW I, NEBUCHADNEZZAR, PRAISE
AND EXALT AND GLORIFY THE
KING OF HEAVEN

DANIEL 4:37

NOW I, NEBUCHADNEZZAR, PRAISE
AND EXALT AND GLORIFY THE
KING OF HEAVEN

DANIEL 4:37

AND THOSE WHO
WALK IN PRIDE
HE IS ABLE TO HUMBLE.

DANIEL 4:37

AND THOSE WHO
WALK IN PRIDE
HE IS ABLE TO HUMBLE.

DANIEL 4:37

AND THOSE WHO
WALK IN PRIDE
HE IS ABLE TO HUMBLE.

DANIEL 4:37

AND THOSE WHO
WALK IN PRIDE
HE IS ABLE TO HUMBLE.

DANIEL 4:37