

# DAY 1

## GOD'S WONDERS

# PHARAOH'S ORDER

---

### FOCUS

EXODUS 1:22

Pharaoh's order to kill the baby Hebrew boys.

### MATERIALS

Pharaoh's hat coloring page (1 per child)

Crayons, scissors and glue

### ACTIVITY

#### LEAVING HOME

**TALK:** Let's rewind back to before Moses was born. Pharaoh did not like how the Israelites were increasing. They were too numerous and too powerful! And even after Pharaoh enslaved them, they grew even more. So Pharaoh took matters into his own hands.

**ACTIVITY:** Let's wear our Pharaoh hat and act out Exodus 1:22.

### CORRESPONDING VERSE

THEN PHARAOH GAVE THIS ORDER TO ALL HIS PEOPLE. "EVERY HEBREW BOY THAT IS BORN YOU MUST THROW INTO THE NILE, BUT LET EVERY GIRL LIVE."

EXODUS 1:22

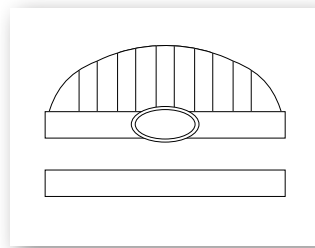

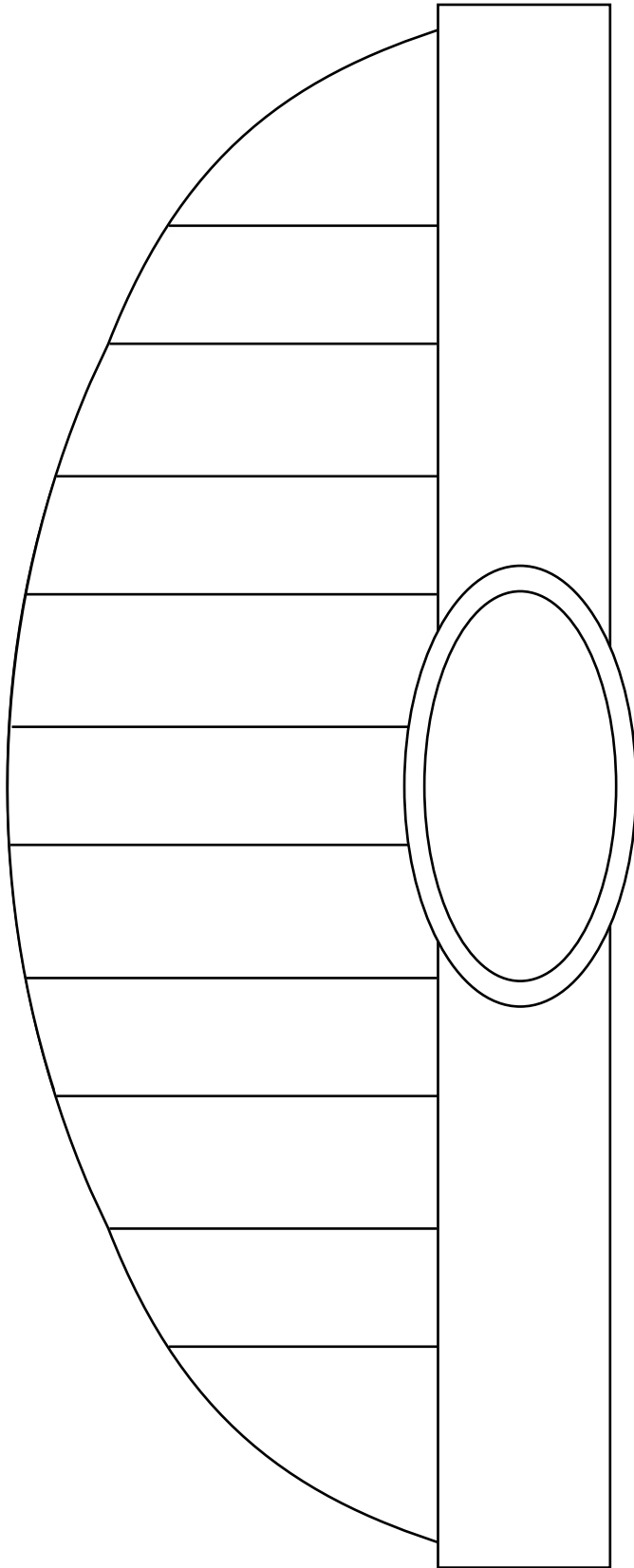

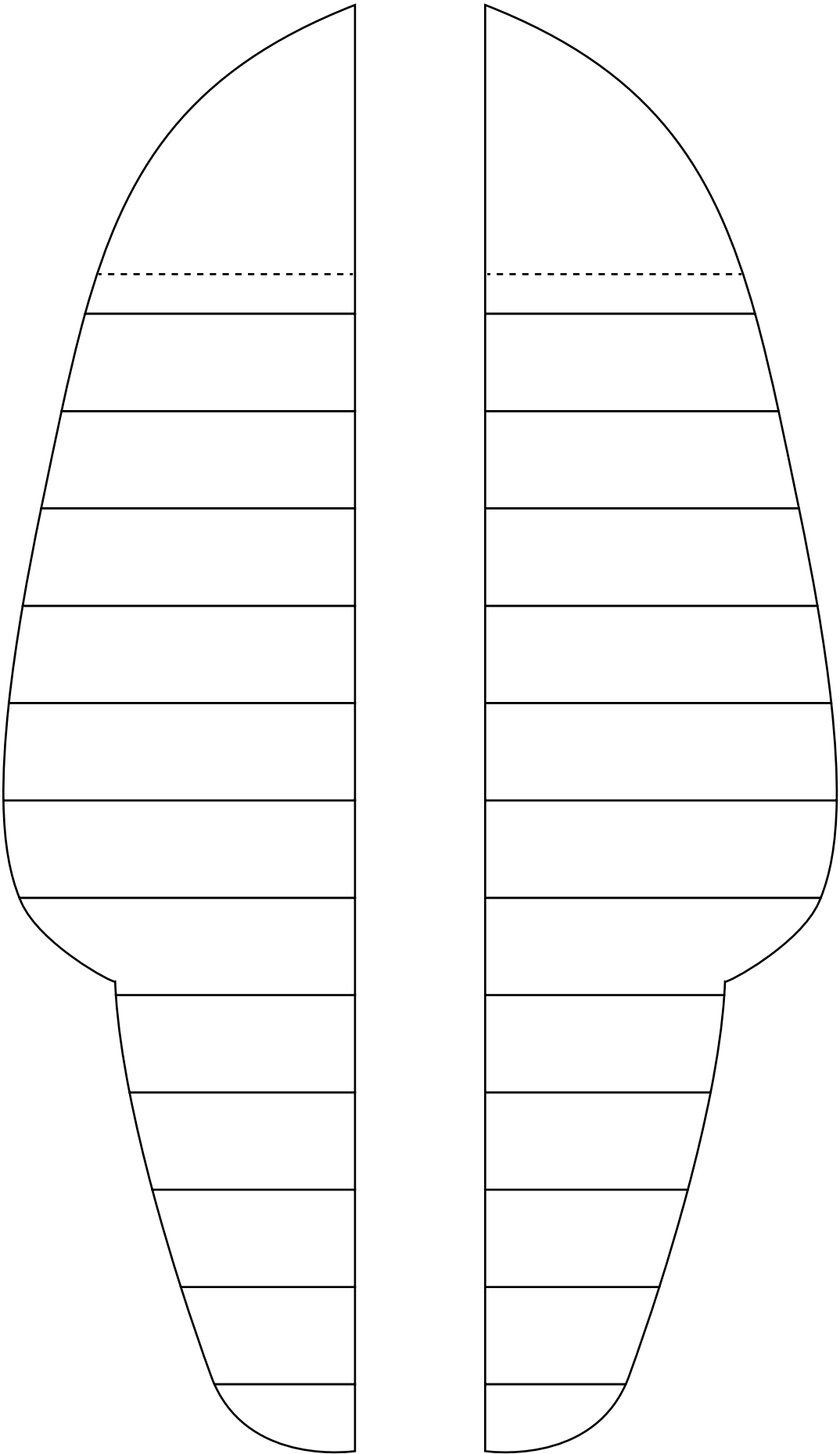

# DAY 2

## GOD'S WONDERS

# ISRAELITE'S REACTION TO MOSES

---

### FOCUS

EXODUS 4:29-31

How the Israelites reacted after Moses came back to Egypt and told them everything God had said.

### MATERIALS

Worship music

### ACTIVITY

#### BOW DOWN AND WORSHIP

**TALK:** When Moses came back to Egypt, how do you think the Israelites reacted?

**ACTIVITY:** Let's read Exodus 4:29-31 then worship like we are the Israelites and are about to be set free!

### CORRESPONDING VERSE

MOSES AND AARON BROUGHT TOGETHER ALL THE ELDERS OF THE ISRAELITES, AND AARON TOLD THEM EVERYTHING THE LORD HAD SAID TO MOSES. HE ALSO PERFORMED THE SIGNS BEFORE THE PEOPLE, AND THEY BELIEVED. AND WHEN THEY HEARD THAT THE LORD WAS CONCERNED ABOUT THEM AND HAD SEEN THEIR MISERY, THEY BOWED DOWN AND WORSHIPED.

EXODUS 4:29-31

# DAY 3

## GOD'S WONDERS

### ISRAELITES REACTION TO NO STRAW

---

#### FOCUS

EXODUS 5:19-21

The Israelites reaction to Moses and Aaron after they were given no more straw to make bricks.

#### MATERIALS

#### ACTIVITY

##### BAD REACTION

**TALK:** After the Israelites were given no more straw to make bricks, how do you think they reacted? Were they happy that their job just got harder? When Moses came they were excited and worshipping, but now when things got harder they complained.

**ACTIVITY:** Read Exodus 5:19-21. Let's pray that when God promises us something, and when it gets tough, we will trust in him and not get upset how things have gotten harder, but be joyful that God is moving to make change!

#### CORRESPONDING VERSE

THE ISRAELITE OVERSEERS REALIZED THEY WERE IN TROUBLE WHEN THEY WERE TOLD, "YOU ARE NOT TO REDUCE THE NUMBER OF BRICKS REQUIRED OF YOU FOR EACH DAY." WHEN THEY LEFT PHARAOH, THEY FOUND MOSES AND AARON WAITING TO MEET THEM, AND THEY SAID, "MAY THE LORD LOOK ON YOU AND JUDGE YOU! YOU HAVE MADE US OBNOXIOUS TO PHARAOH AND HIS OFFICIALS AND HAVE PUT A SWORD IN THEIR HANDS TO KILL US!"

EXODUS 5:19-21

# DAY 4

## GOD'S WONDERS

### WHICH PLAGUE AFFECTED WHERE?

---

#### FOCUS

EXODUS 5:1-9

A reminder about which plague affected Egypt, and which affected Goshen.

#### MATERIALS

9 plagues coloring page (1 per child)

Crayons, scissors and glue

#### ACTIVITY

#### 9 PLAGUES

**TALK:** Let's remind our Tiny Arrows about last week. About each plague and which area is affected.

**ACTIVITY:** Cut out each plague and place them in the correct order, and which ones affected Egypt and which affected Goshen.

#### CORRESPONDING VERSE

CUT THE PLAGUES IN ORDER FROM 1-9 IN THE ORDER THEY APPEARED	
EGYPT	GOSHEN

GLUE THE PLAGUES IN ORDER FROM 1-9 IN THE AREAS THEY AFFECTED

EGYPT

GOSHEN

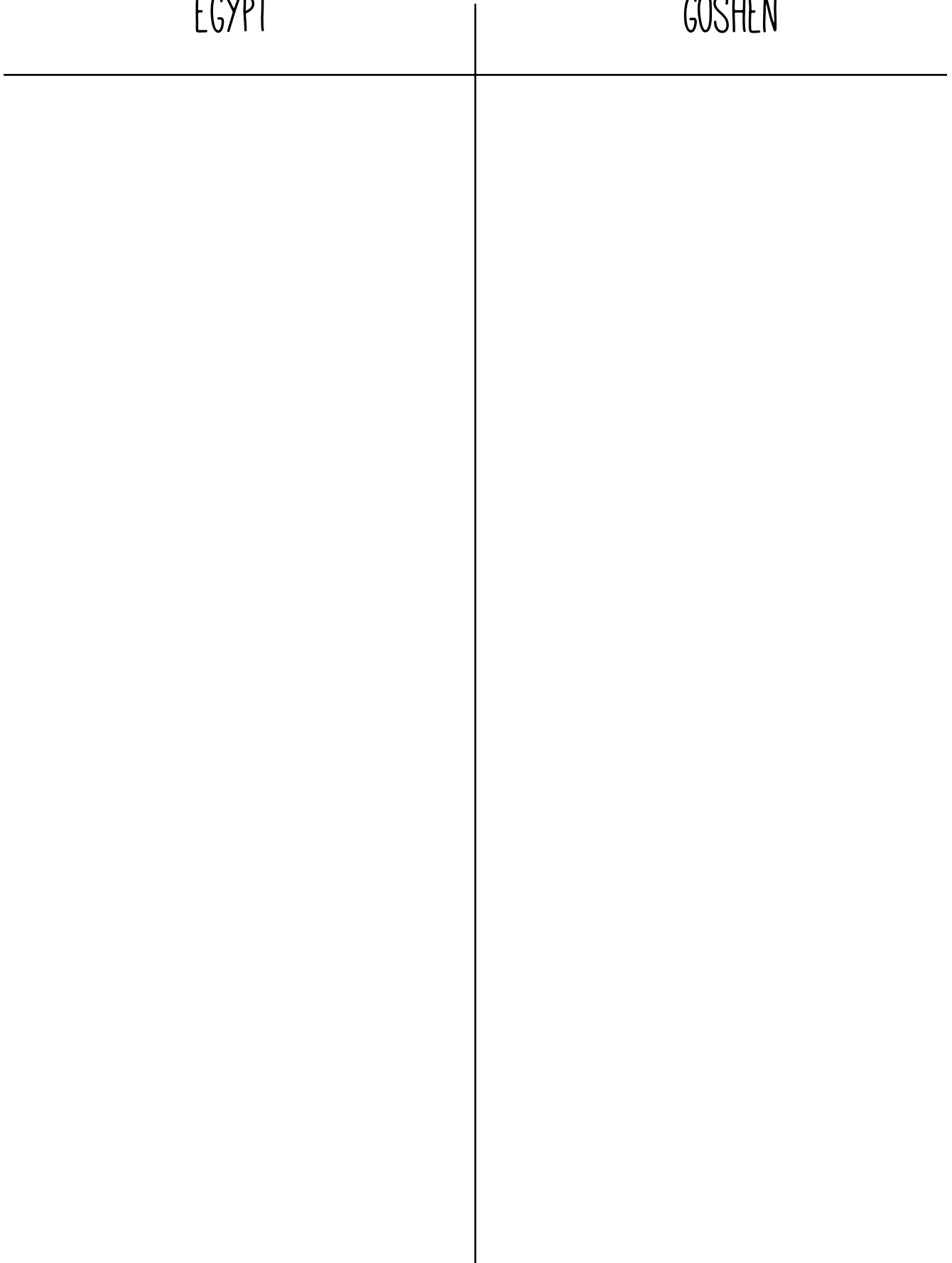

# EGYPT

CUT OUT WHICH PLAGUES AFFECTED EGYPT

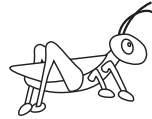
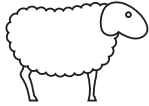

# GOSHEN

CUT OUT WHICH PLAGUES AFFECTED GOSHEN

