



JUSTICE WEEK 1



JUSTICE

JUSTICE WEEK 1

THE LORD'S THRONE

FOCUS

PSALM 89:14, 99:4-5 & 97:2-4, EZEKIEL 1:26,
AMOS 5:24 & REVELATION 4:3 & 22:1

Just like a king on earth, the Lord
has a throne in heaven!

MATERIALS

The Lord's Throne picture

The Lord's Throne coloring page (1 per child)

Throne, pedestal, river and surroundings

Red, orange, yellow, green, blue, indigo and violet streamers

Bucket of water and 1 empty cup per child

Righteousness & Justice sign (1 per child)

Gold and yellow paint, crayons and glue

ACTIVITIES

1. INTRODUCTION

TALK: Ask the children if they know about the Lord's throne in heaven!

ACTIVITY: Show children the The Lord's Throne picture and hang nearby for them to see.

2. THE THRONE

TALK: The Lord sits on a chair that looks like lapis lazuli, or a pretty dark blue with streaks of gold!

ACTIVITY: Have the children color the throne blue and gold and paint gold streaks on the **blue plastic chair representing the throne.**

CORRESPONDING VERSE

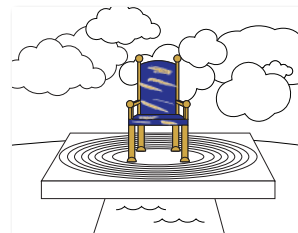

ABOVE THE VAULT OVER THEIR HEADS WAS WHAT LOOKED LIKE A THRONE OF LAPIS LAZULI, AND HIGH ABOVE ON THE THRONE WAS A FIGURE LIKE THAT OF A MAN.

EZEKIEL 1:26

ACTIVITIES

3. A RAINBOW

TALK: There is a rainbow around His throne!

ACTIVITY: Color the rainbow on the coloring page and circle streamers in the colors of the rainbow around the chair.

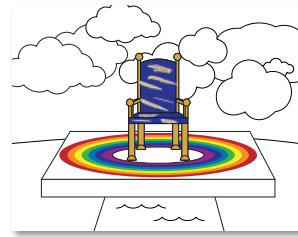

CORRESPONDING VERSE

RAINBOW THAT SHONE LIKE AN EMERALD ENCLOSED THE THRONE.

REVELATION 4:3

4. THE FOUNDATION

TALK: The foundation, or where God's throne sits, is righteousness and justice!

ACTIVITY: Glue "Righteousness and Justice" on the pedestal of the coloring page and color and glue **Righteousness and Justice** to the side of the pedestal under the blue chair.



RIGHTEOUSNESS
& JUSTICE

RIGHTEOUSNESS AND JUSTICE ARE THE FOUNDATION OF YOUR THRONE; LOVE AND FAITHFULNESS GO BEFORE YOU.

PSALM 89:14

5. DARK & LIGHT

TALK: Clouds and thick darkness surround His throne and it is lit up with lightening!

ACTIVITY: Color the clouds and glue lightening around the throne on the coloring page. Then paint lightening on the clouds surrounding the throne.

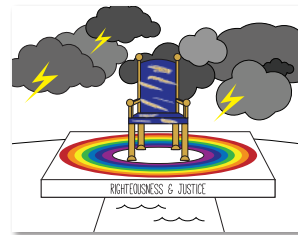

CLOUDS AND THICK DARKNESS SURROUND HIM; RIGHTEOUSNESS AND JUSTICE ARE THE FOUNDATION OF HIS THRONE. FIRE GOES BEFORE HIM AND CONSUMES HIS FOES ON EVERY SIDE. HIS LIGHTNING LIGHTS UP THE WORLD; THE EARTH SEES AND TREMBLES.

PSALM 97:2-4

6. WATER

TALK: There is a river of living water that comes from His throne!

ACTIVITY: Color the water blue on the coloring page. Let the children use their cups to take water from the bucket and pour it into the river until the bucket is empty.

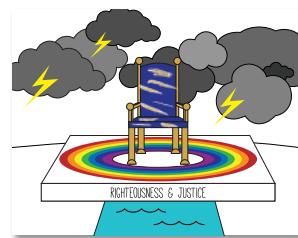

THEN THE ANGEL SHOWED ME A RIVER OF THE WATER OF LIFE, AS CLEAR AS CRYSTAL, FLOWING FROM THE THRONE OF GOD AND OF THE LAMB.

REVELATION 22:1

ACTIVITIES

7. DOWN THE RIVER

TALK: Righteousness and justice flow from the foundation of God's throne into the river!

ACTIVITY: After the children are done filling the water, place the Righteousness & Justice sign in the river and encourage the children to get one.



8. PRAISE BEFORE HIS THRONE

TALK: God loves justice! It is apart of his foundation and He loves to give us what is right and just!

ACTIVITY: Dance and sing to a worship song around the throne.

OPTIONAL: Hand out each child a bible verse to take home.

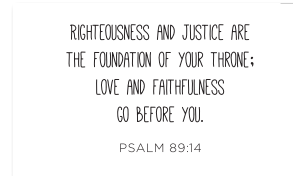

CORRESPONDING VERSE

BUT LET JUSTICE ROLL ON LIKE A RIVER, RIGHTEOUSNESS LIKE A NEVER-FAILING STREAM!

AMOS 5:24

THE KING IS MIGHTY, HE LOVES JUSTICE— YOU HAVE ESTABLISHED EQUITY; IN JACOB YOU HAVE DONE WHAT IS RIGHT AND JUST. EXALT THE LORD OUR GOD AND WORSHIP AT HIS FOOTSTOOL; HE IS HOLY.

PSALM 99:4-5

THE LORD'S THRONE

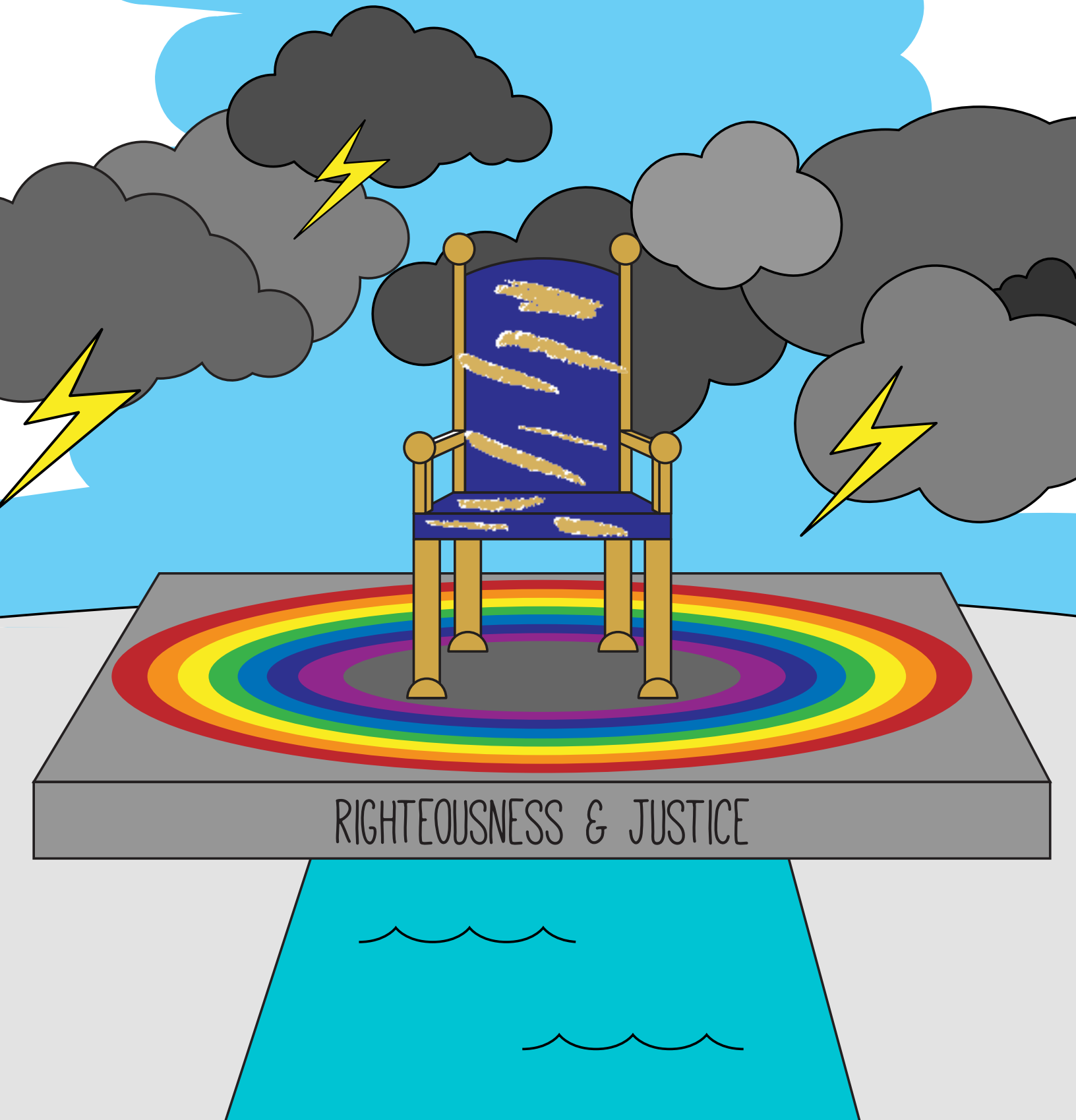

THE THRONE

I used a wooden pallet for the foundation and stapled a large, thick piece of cardboard on the top of the wood for support, and then stapled a silver vinyl tablecloth above that. Then I nailed a thin wooden Righteousness and Justice sign to the front of the foundation. For the chair, I used a dark blue child's plastic outdoor chair.



CLOUDS

Using gray spray paint, I painted 5 pieces of large cardboard. Then I taped 4 pieces of them together, and using a large black sharpie, outlined gray clouds on the cardboard and cut out the tops of the board to follow the line of the clouds. For the last piece of cardboard I drew 4 smaller clouds and cut them out. I used a thicker piece of angled cardboard taped to the back as their base to let them sit freely.

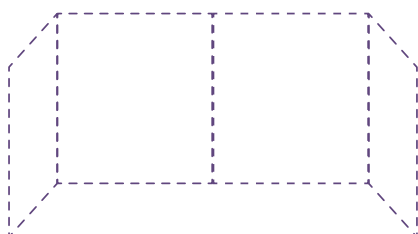
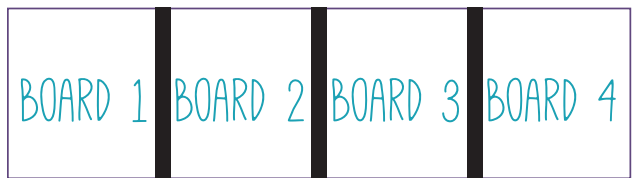

RIVER

For the river in front of the throne, I used 6 small pool noodles and a large blue vinyl rectangular plastic tablecloth. I laid out the noodles to be in the shape of a rectangle, then for the two end noodles, I cut off 4 inches, so it was not as wide. For the other noodles, I cut one end to be in the shape of a v, so the v end would fit snug into the top and bottom noodle. I taped the v noodle against the edges of the other noodles. For better support, you can also tape the two middle noodles together.

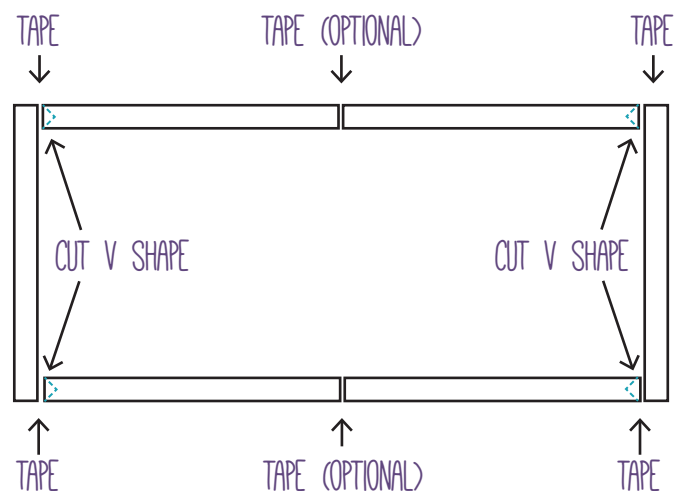

RIVER

When the noodles were in the shape of a rectangle, I placed the blue vinyl tablecloth on top. Then I flipped the tablecloth and noodle formation upside down, making sure the rectangle was in the middle of the table cloth. I loosely taped the edges of the tablecloth to the bottom of the noodles so when it is flipped over, the table cloth would go to the ground when water was in it and would not be too tight. For the start of class I filled the pool partly with water so the children could add more during their lesson.





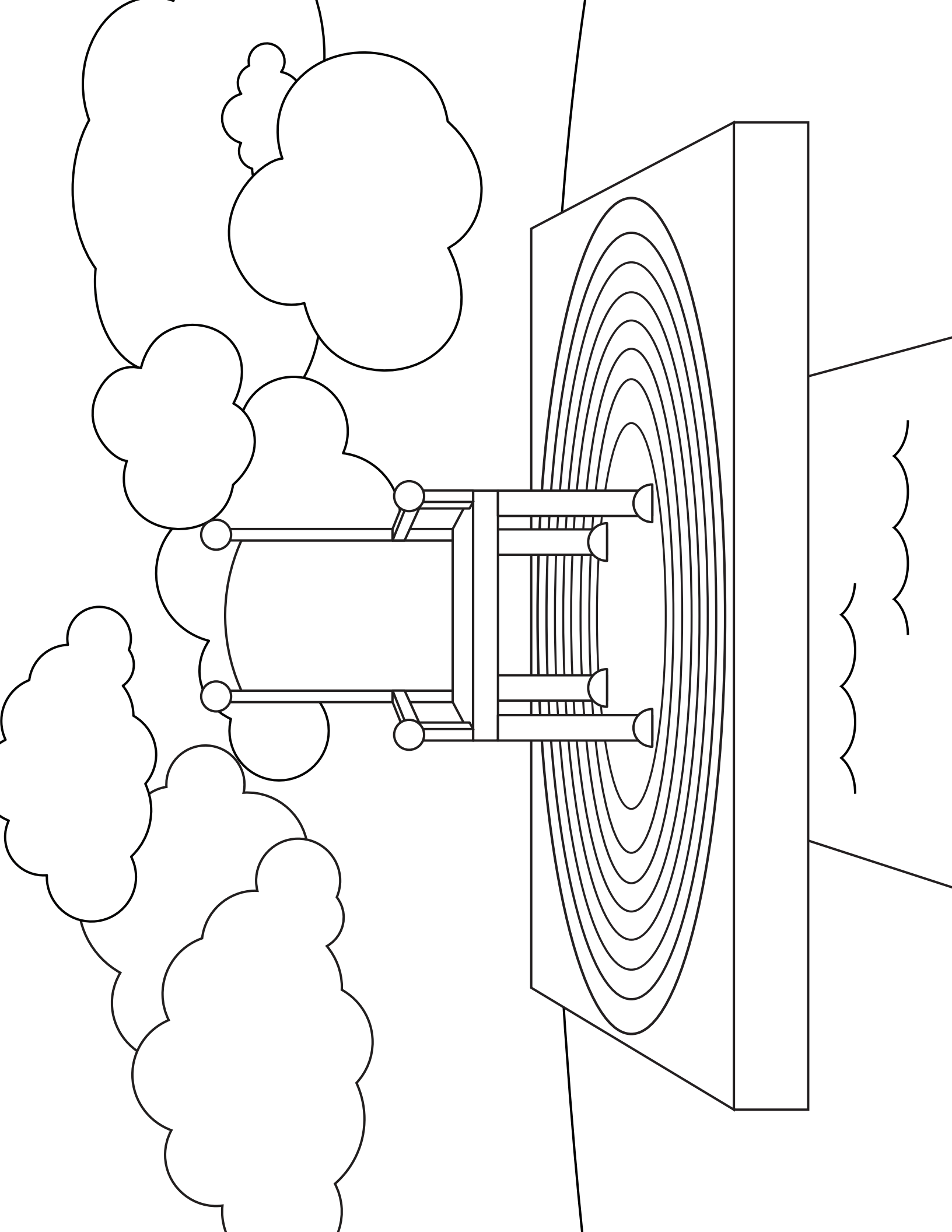

RIGHTEOUSNESS & JUSTICE

RIGHTEOUSNESS & JUSTICE

RIGHTEOUSNESS & JUSTICE

RIGHTEOUSNESS & JUSTICE

RIGHTEOUSNESS & JUSTICE

RIGHTEOUSNESS & JUSTICE

RIGHTEOUSNESS & JUSTICE

RIGHTEOUSNESS & JUSTICE

RIGHTEOUSNESS & JUSTICE

RIGHTEOUSNESS
& JUSTICE

RIGHTEOUSNESS
& JUSTICE

RIGHTEOUSNESS
& JUSTICE

RIGHTEOUSNESS
& JUSTICE

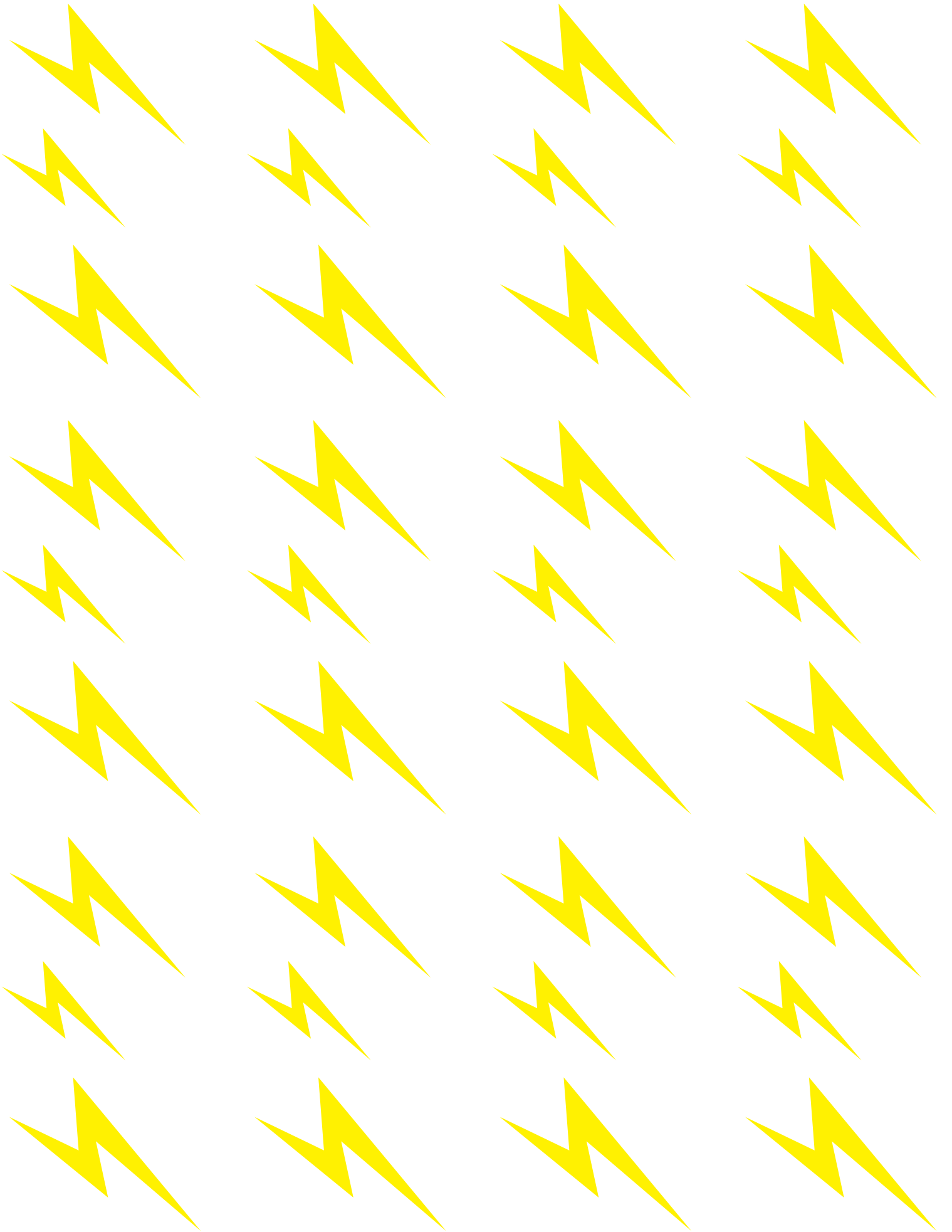

RIGHTEOUSNESS & JUSTICE SIGN

PRINT OUT STENCIL & USE IT ON THE WOOD

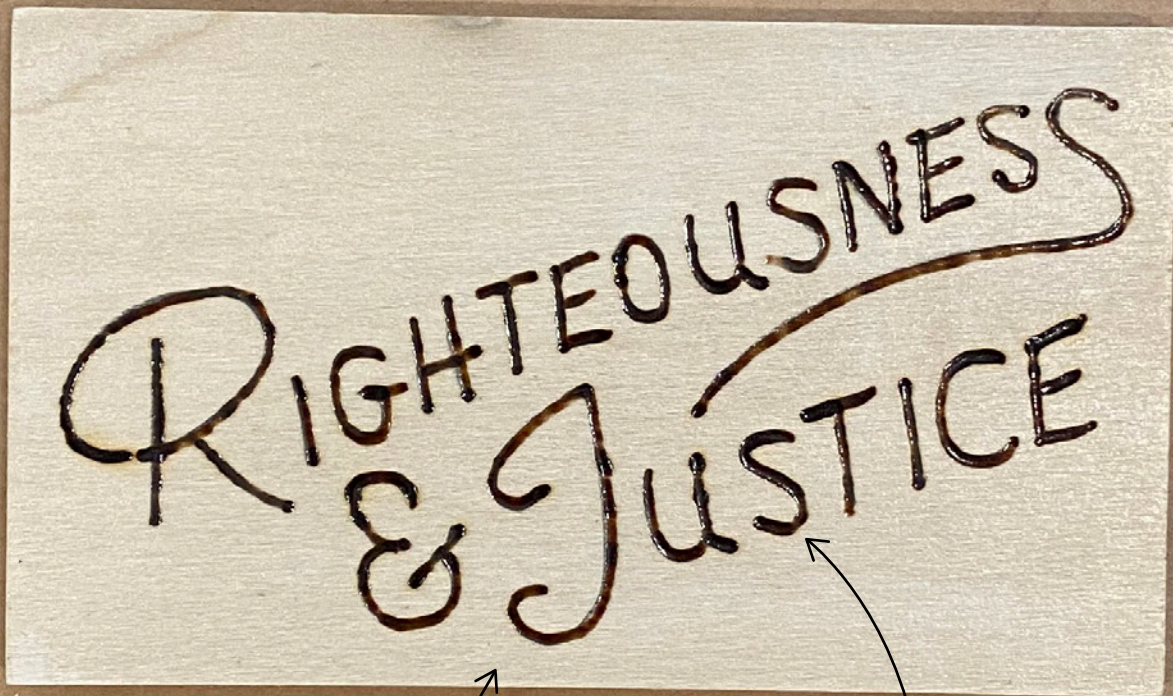
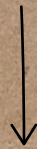

6" X 3.5" WOOD

USE POLY TO
SECURE THE WOOD

I WOOD BURNED THE SIGN
YOU CAN ALSO USE A MARKER

*ANOTHER OPTION IS TO PRINT THE SIGN & PLACE IN A BAGGIE SO IT IS WATERPROOF

RIGHTEOUSNESS
& JUSTICE

RIGHTEOUSNESS
& JUSTICE

RIGHTEOUSNESS
& JUSTICE

— — — — —
| — — — — —
— — — — —
| — — — — —
| — — — — —
— — — — —
| — — — — —
| — — — — —
— — — — —
| — — — — —
| — — — — —
— — — — —
| — — — — —
| — — — — —
— — — — —

RIGHTEOUSNESS AND JUSTICE ARE
THE FOUNDATION OF YOUR THRONE;
LOVE AND FAITHFULNESS
GO BEFORE YOU.

PSALM 89:14

— — — — —
| — — — — —
| — — — — —
— — — — —
| — — — — —
| — — — — —
— — — — —
| — — — — —
| — — — — —
— — — — —
| — — — — —
| — — — — —
— — — — —
| — — — — —
| — — — — —
— — — — —

RIGHTEOUSNESS AND JUSTICE ARE
THE FOUNDATION OF YOUR THRONE;
LOVE AND FAITHFULNESS
GO BEFORE YOU.

PSALM 89:14

— — — — —
| — — — — —
| — — — — —
— — — — —
| — — — — —
| — — — — —
— — — — —
| — — — — —
| — — — — —
— — — — —
| — — — — —
| — — — — —
— — — — —
| — — — — —
| — — — — —
— — — — —

RIGHTEOUSNESS AND JUSTICE ARE
THE FOUNDATION OF YOUR THRONE;
LOVE AND FAITHFULNESS
GO BEFORE YOU.

PSALM 89:14

— — — — —
| — — — — —
| — — — — —
— — — — —
| — — — — —
| — — — — —
— — — — —
| — — — — —
| — — — — —
— — — — —
| — — — — —
| — — — — —
— — — — —
| — — — — —
| — — — — —
— — — — —

RIGHTEOUSNESS AND JUSTICE ARE
THE FOUNDATION OF YOUR THRONE;
LOVE AND FAITHFULNESS
GO BEFORE YOU.

PSALM 89:14