



BLOOD WEEK 1

BLOOD

BLOOD WEEK 1

WATER & LAMBS

FOCUS

EXODUS 7:15-21 & 12:7 & 23

The first plague in Egypt was the water turning to blood, and the last was the death of the firstborn, but the Israelites were saved by the blood of a lamb!

MATERIALS

Water & Lambs picture

Moses & Aaron by the Nile coloring page (1 per child)

River, 2 cups and 1 pitcher water

Staff (1 per child)

Red PAAS pellets, frosting (1/2 oz) (1 set per child) and vinegar

Red food coloring (about 3-5 drops per cup/pitcher)

Moses, Aaron and Pharaoh actor

First to Last Plague coloring page (1 per child)

Consequences coloring page (1 per child)

House and snack (1 per child)

Crayons, red paint and glue

ACTIVITIES

1. INTRODUCTION

TALK: Ask the children if they know about the first and last plague in Egypt!

ACTIVITY: Show children the Water & Lambs picture and hang nearby for them to see.



2. GO TO PHARAOH

TALK: Moses went to pharaoh to ask him to let God's people go, and Pharaoh said no! So God told Moses to go to the Nile River and show Pharaoh a sign that God was bigger than him and his gods!

ACTIVITY: Coloring page of Moses, Aaron and Pharaoh by the Nile.



CORRESPONDING VERSE

GO TO PHARAOH IN THE MORNING AS HE GOES OUT TO THE RIVER. CONFRONT HIM ON THE BANK OF THE NILE, EXODUS 7:15A

ACTIVITIES

3. GO TO THE RIVER

TALK: God wanted Moses and Aaron to show Pharaoh who was the real God! So Moses and Aaron were supposed to take their staff's and walk to the river.

ACTIVITY: Grab a staff and walk to the river.

4. NILE TO BLOOD

TALK: Moses told Pharaoh that the water in the Nile would change to blood!

ACTIVITY: Tell Pharaoh that the Nile will change to blood and he won't be able to drink it!

5. BLOOD WILL BE EVERYWHERE

TALK: Moses was suppose to strike the Nile River for the water to change, and Aaron was suppose to stretch out his hand over the water by the river, and not only would the Nile turn to blood, but all the water everywhere! Even the water in people's water bottles.

ACTIVITY: Show children the cups and pitcher of water.

CORRESPONDING VERSE

AND TAKE IN YOUR HAND
THE STAFF THAT WAS
CHANGED INTO A SNAKE.

EXODUS 7:15B

BY THIS YOU WILL KNOW THAT
I AM THE LORD: WITH THE
STAFF THAT IS IN MY HAND
I WILL STRIKE THE WATER
OF THE NILE, AND IT WILL BE
CHANGED INTO BLOOD. THE FISH
IN THE NILE WILL DIE, AND
THE RIVER WILL STINK; THE
EGYPTIANS WILL NOT BE ABLE
TO DRINK ITS WATER.”

EXODUS 7:17-18

THE LORD SAID TO MOSES,
“TELL AARON, ‘TAKE YOUR
STAFF AND STRETCH OUT
YOUR HAND OVER THE
WATERS OF EGYPT—OVER
THE STREAMS AND CANALS,
OVER THE PONDS AND ALL
THE RESERVOIRS—AND THEY
WILL TURN TO BLOOD.’ BLOOD
WILL BE EVERYWHERE IN
EGYPT, EVEN IN VESSELS OF
WOOD AND STONE.”

EXODUS 7:19

ACTIVITIES

6. STRIKE THE WATER

TALK: Moses struck the water with his staff and Aaron lifted his staff in the air and the water everywhere turned to blood!

ACTIVITY: Have children strike the river with their staff and watch it turn red. Then have them lift their staff high and then show them the red water in the buckets and bottles!

CORRESPONDING VERSE

MOSES AND AARON DID JUST AS THE LORD COMMANDED. HE RAISED HIS STAFF IN THE PRESENCE OF PHARAOH AND HIS OFFICIALS AND STRUCK THE WATER OF THE NILE, AND ALL THE WATER WAS CHANGED INTO BLOOD. THE FISH IN THE NILE DIED, AND THE RIVER SMELLED SO BAD THE THE EGYPTIANS COULD NOT DRINK ITS WATER. BLOOD WAS EVERYWHERE IN EGYPT.
EXODUS 7:20-21

7. FIRST TO LAST PLAGUE

TALK: The first plague God gave Pharaoh was the waters turning to blood! The last plague was the death of the first born! But God wanted to save his people and used the blood of the lamb to do it!

ACTIVITY: Have children color the First to Last Plague coloring page of the.

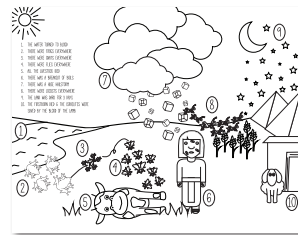

THE BLOOD WILL BE A SIGN FOR YOU ON THE HOUSES WHERE YOU ARE, AND WHEN I SEE THE BLOOD, I WILL PASS OVER YOU.

EXODUS 12:13

8. OBEY OR NOT

TALK: The last plague was the death of the first born. But God was going to protect the Israelites! All they had to do was to take a lamb's blood and smear the blood on the door posts of their houses!

ACTIVITY: Color blood on the first door and see the consequences if they obeyed or not.

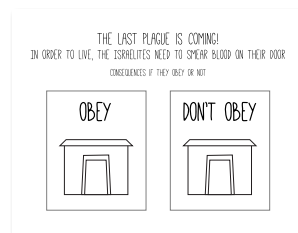

THEN THEY ARE TO TAKE SOME OF THE BLOOD AND PUT IT ON THE SIDES AND TOPS OF THE DOORFRAMES OF THE HOUSES WHERE THEY EAT THE LAMBS.

EXODUS 12:7

ACTIVITIES

9. BLOOD ON THE DOOR

TALK: The blood acted as protection! Whoever had the blood would be saved!

ACTIVITY: Have children paint blood on the door posts of the house then go inside of the house and have a snack.

OPTIONAL: Hand out each child a bible verse to take home.

CORRESPONDING VERSE

WHEN THE LORD GOES THROUGH THE LAND TO STRIKE DOWN THE EGYPTIANS, HE WILL SEE THE BLOOD ON THE TOP AND SIDES OF THE DOORFRAME AND WILL PASS OVER THAT DOORWAY, AND HE WILL NOT PERMIT THE DESTROYER TO ENTER YOUR HOUSES AND STRIKE YOU DOWN.

EXODUS 12:23

WITH THE STAFF THAT IS IN
MY HAND I WILL STRIKE THE WATER
OF THE NILE, AND IT WILL
BE CHANGED INTO BLOOD

EXODUS 7:17

WATER & LAMBS

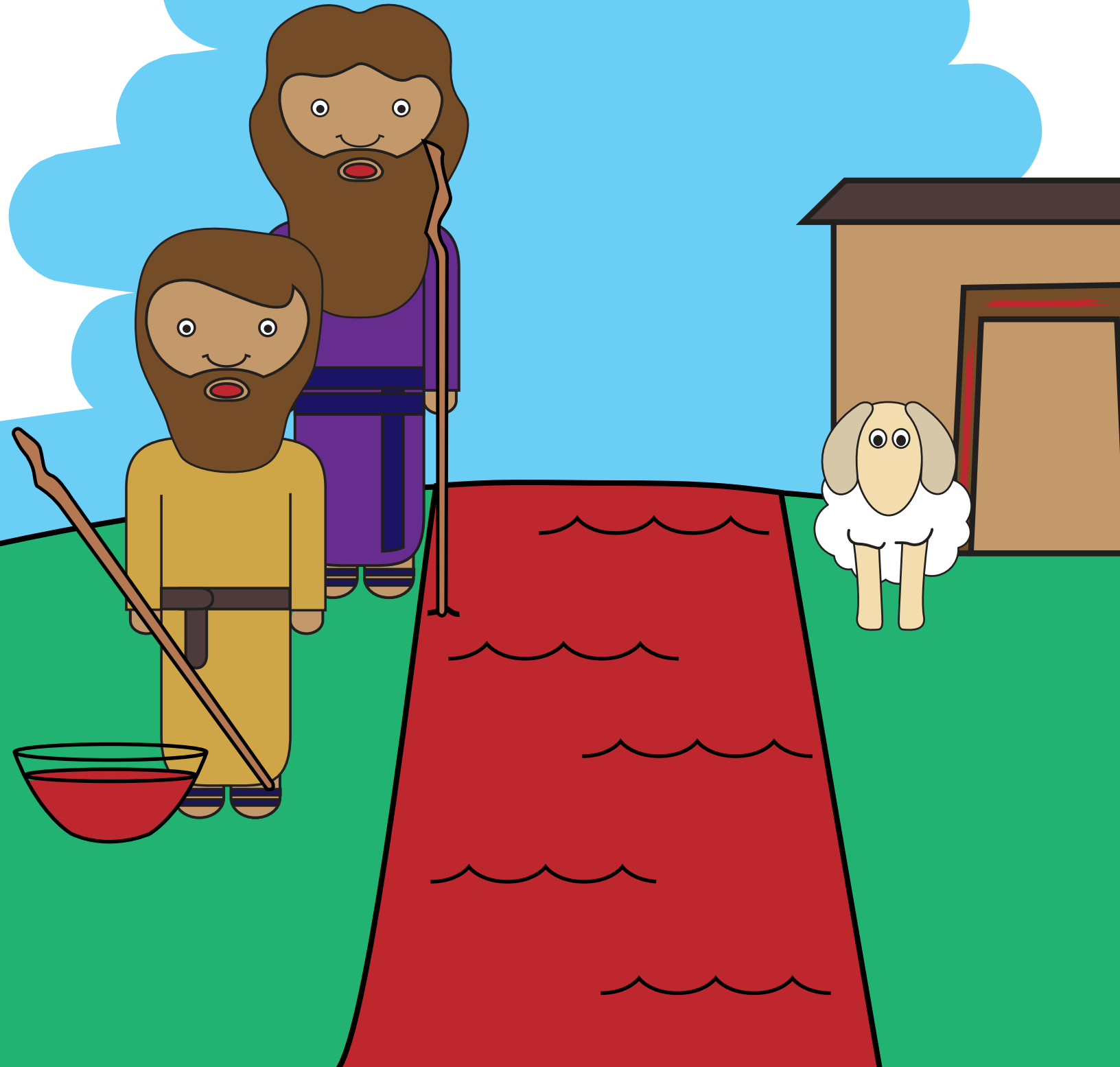

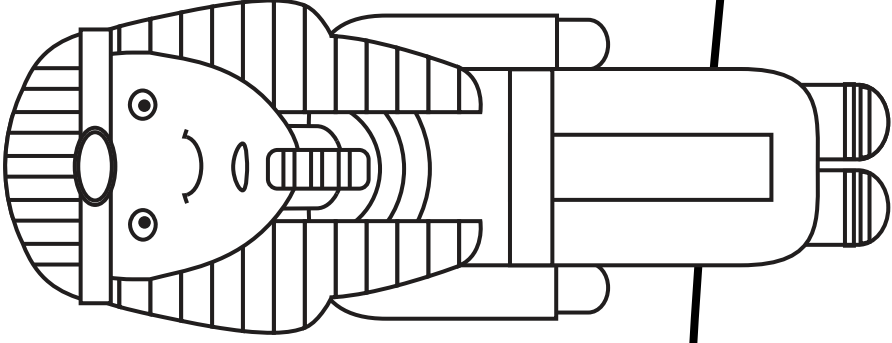

LET MY PEOPLE GO!

NO!

THEN THE WATERS WILL BE TURNED TO BLOOD!

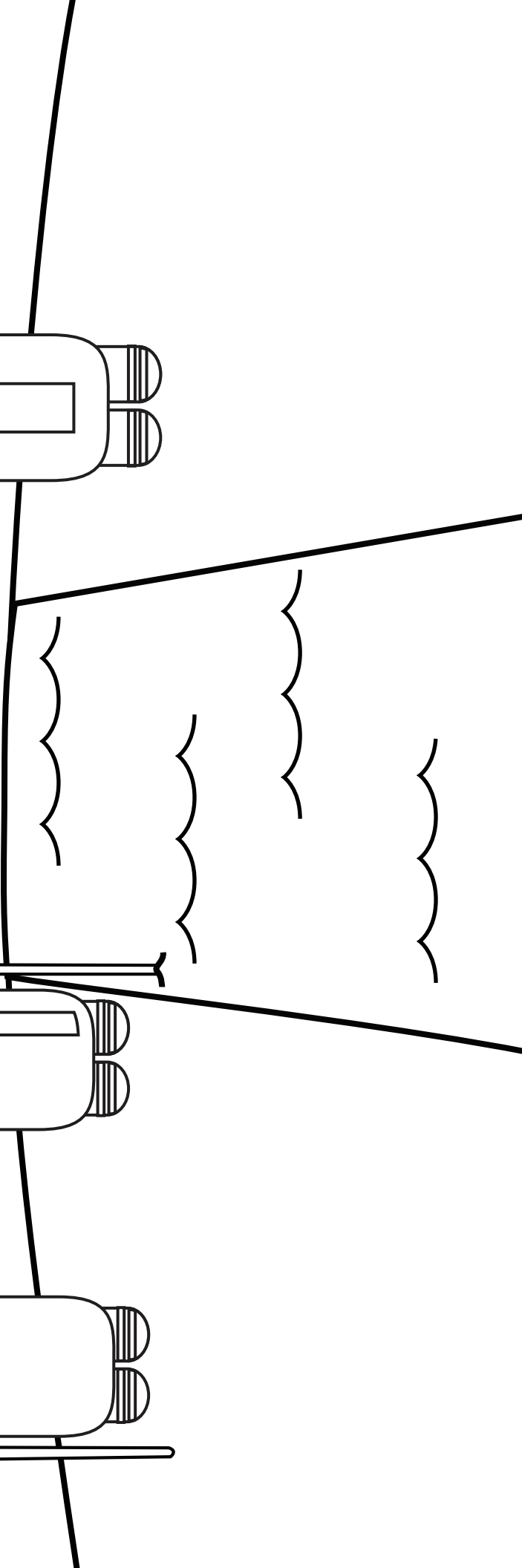
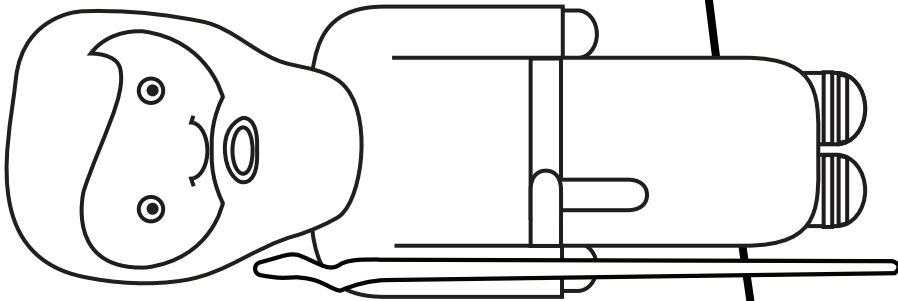
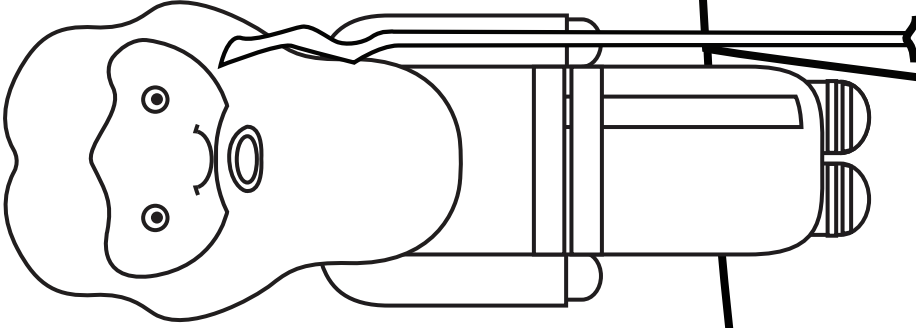

STAFF

I sanded and polyurethaned large sticks to be staves.

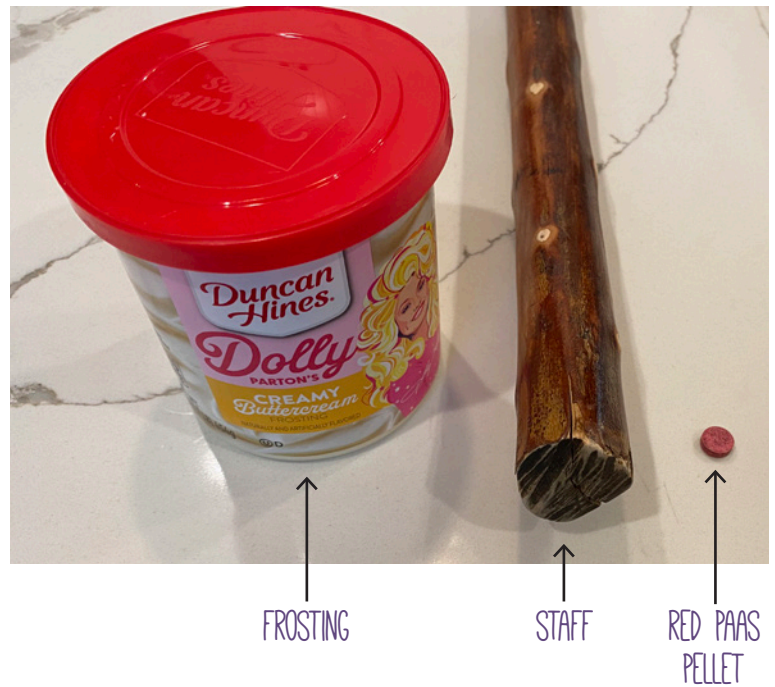

Then I put a small amount of icing on the bottom of the staff and placed the red PAAS pellet in the icing.

When the staff struck the water and vinegar, the PAAS pellet turned the water red.

Note: The water in the river did not all turn red, just a portion of it.

RIVER

For the river in front of the throne, I used 6 small pool noodles and a large blue vinyl rectangular plastic tablecloth. I laid out the noodles to be in the shape of a rectangle, then for the two end noodles, I cut off 4 inches, so it was not as wide. For the other noodles, I cut one end to be in the shape of a v, so the v end would fit snug into the top and bottom noodle. I taped the v noodle against the edges of the other noodles. For better support, you can also tape the two middle noodles together.

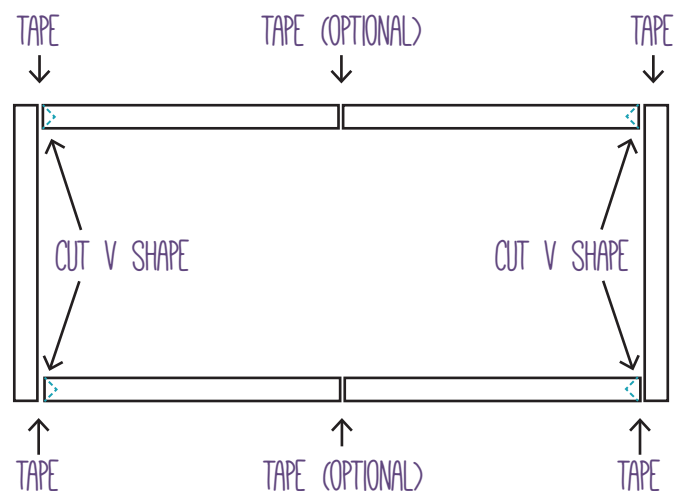

RIVER

When the noodles were in the shape of a rectangle, I placed the blue vinyl tablecloth on top. Then I flipped the tablecloth and noodle formation upside down, making sure the rectangle was in the middle of the table cloth. I loosely taped the edges of the tablecloth to the bottom of the noodles so when it is flipped over, the table cloth would go to the ground when water was in it and would not be too tight. For the start of class I filled the pool with water and a few cups of vinegar.



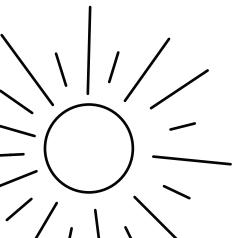

1. THE WATER TURNED TO BLOOD
2. THERE WERE FROGS EVERYWHERE
3. THERE WERE GNATS EVERYWHERE
4. THERE WERE FLIES EVERYWHERE
5. ALL THE LIVESTOCK DIED
6. THERE WAS A BREAKOUT OF BOILS
7. THERE WAS A HUGE HAILSTORM
8. THERE WERE LOCUSTS EVERYWHERE
9. THE LAND WAS DARK FOR 3 DAYS
10. THE FIRSTBORN DIED & THE ISRAELITES WERE SAVED BY THE BLOOD OF THE LAMB

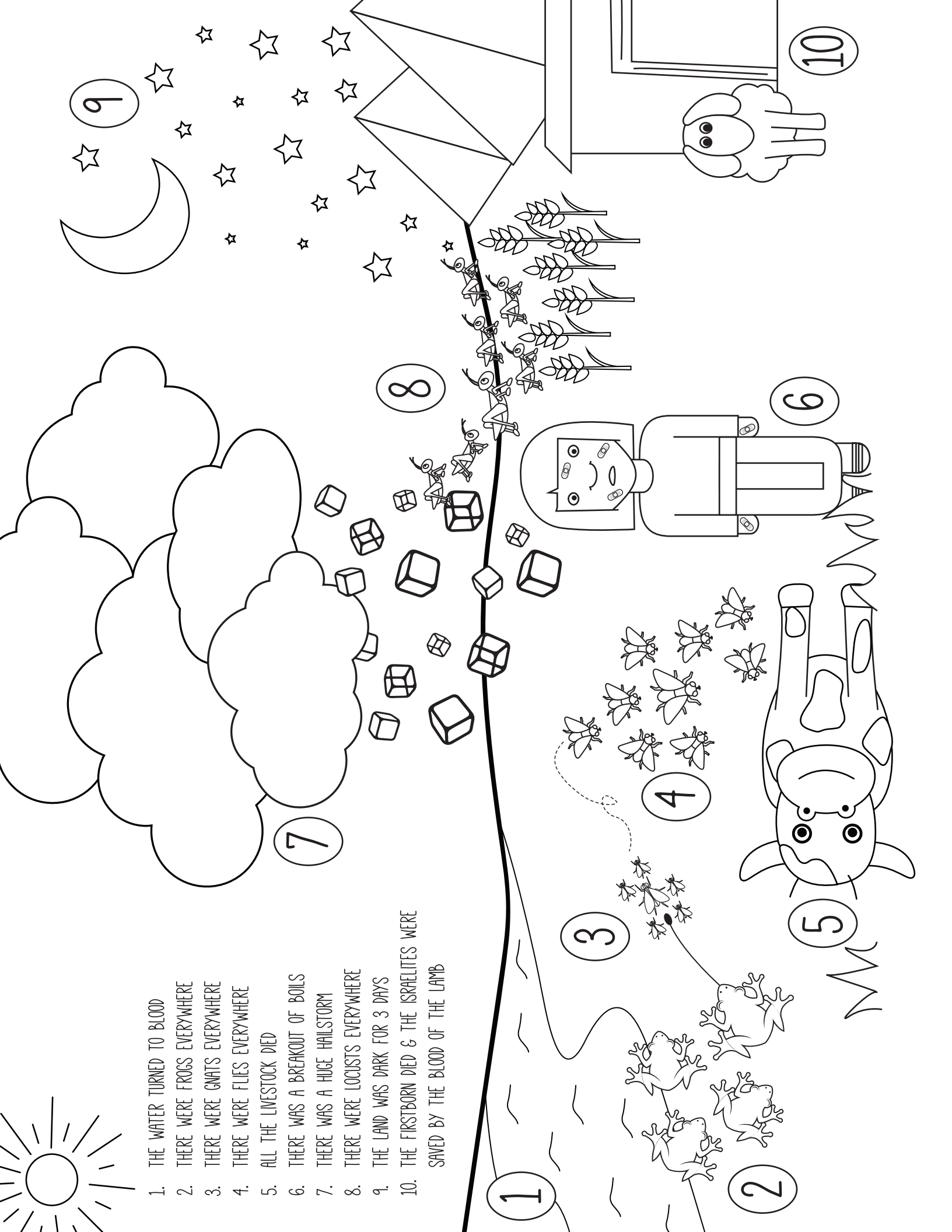

OBEY OR NOT

PRINT

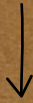

PRINT & CUT OUT

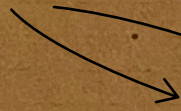

OBEY

DON'T OBEY

THE LAST PLAGUE IS COMING
IN ORDER TO LIVE, THE ISRAELITES NEED TO SMEAR
CONSEQUENCES IF THEY OBEY OR NOT

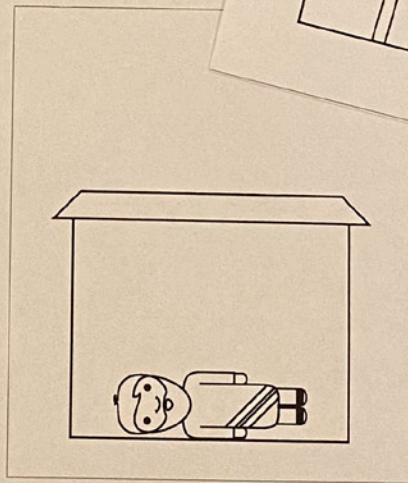
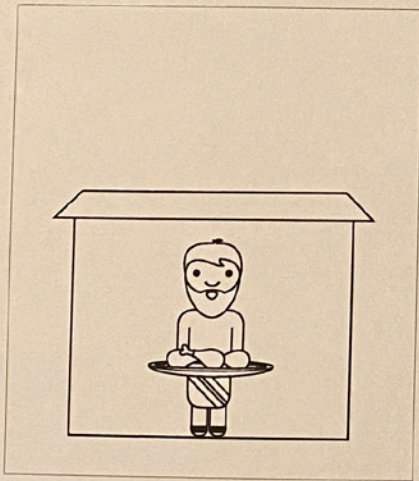

OBEY OR NOT

THE LAST PLAGUE IS COMING!
IN ORDER TO LIVE, THE ISRAELITES NEED TO SMEAR BLOOD ON THEIR DOOR
CONSEQUENCES IF THEY OBEY OR NOT

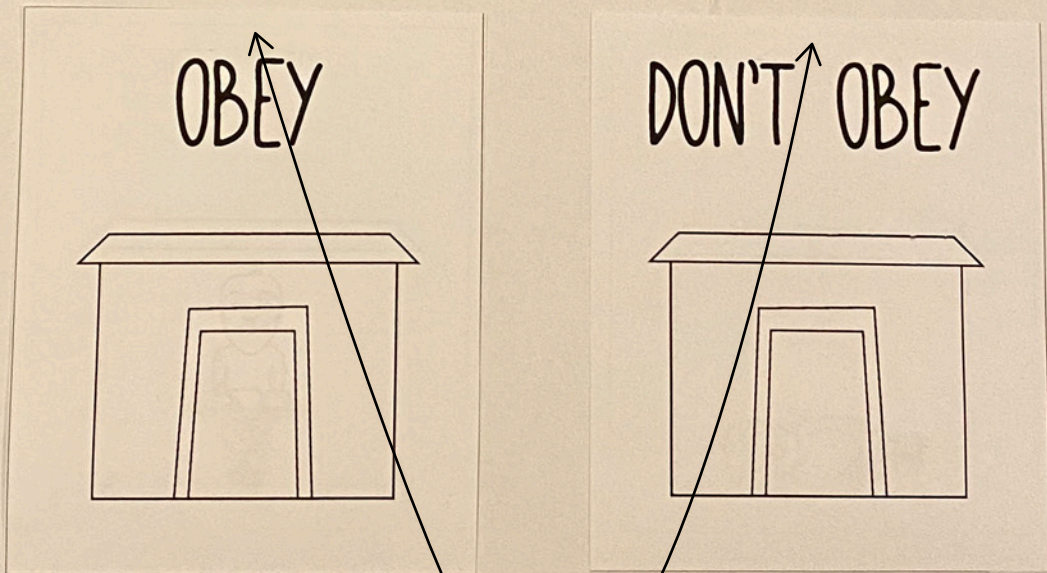

TAPE OVER THE BOXES

OBEY

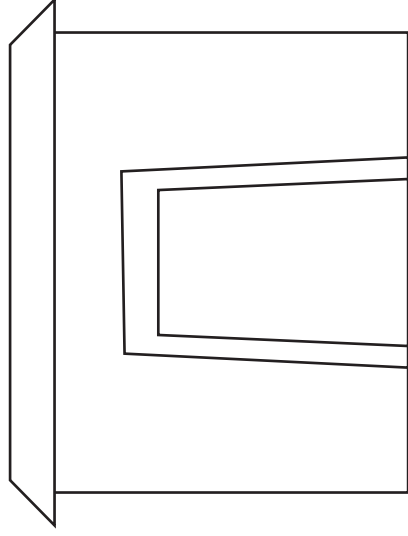

DON'T OBEY

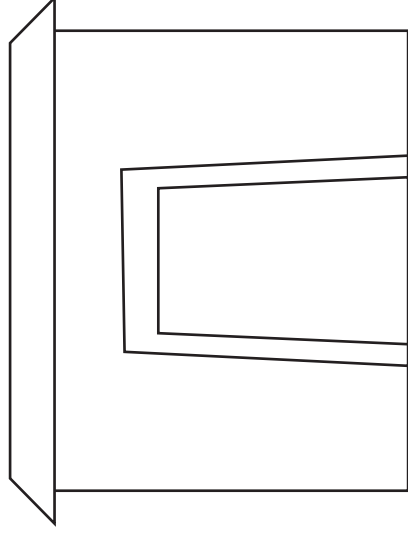

THE LAST PLAGUE IS COMING!
IN ORDER TO LIVE, THE ISRAELITES NEED TO SMEAR BLOOD ON THEIR DOOR

CONSEQUENCES IF THEY OBEY OR NOT

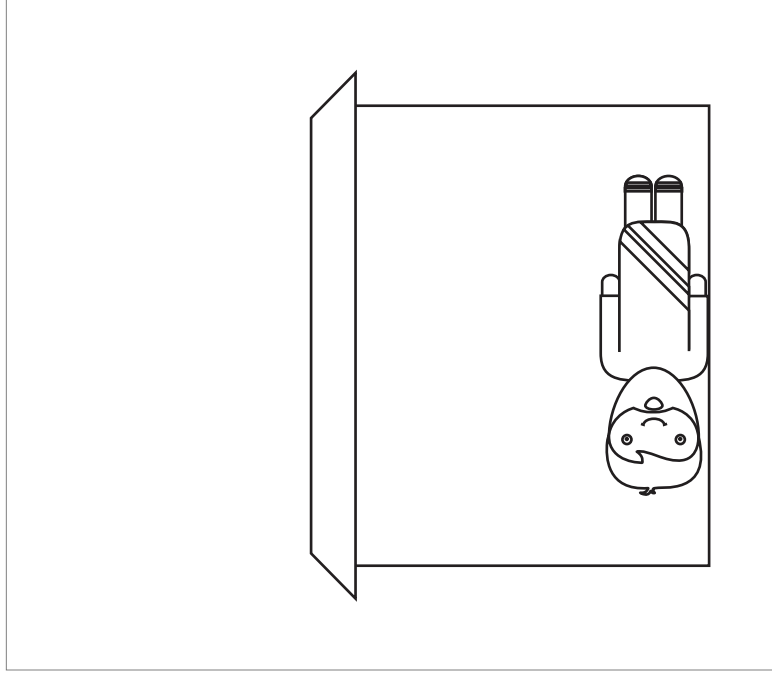
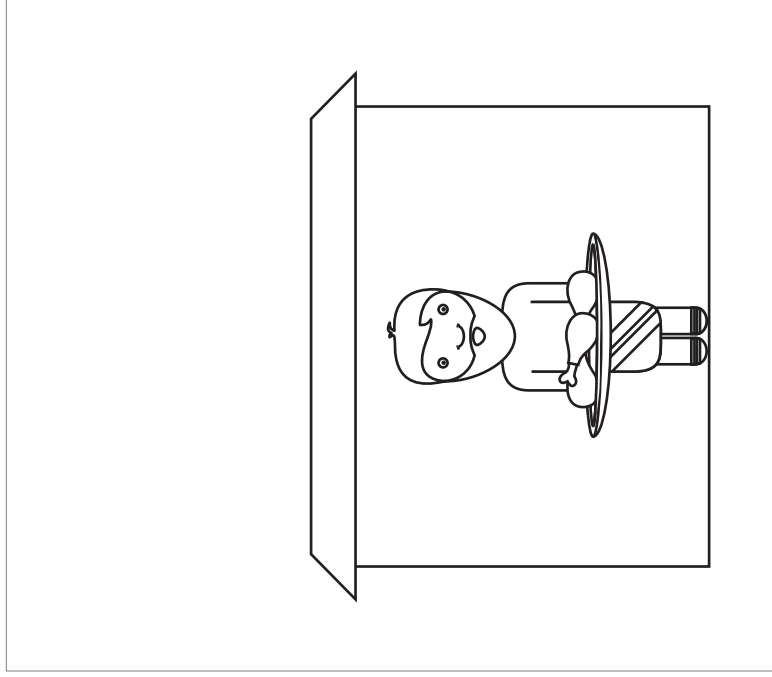

LARGE HOUSE

Tape together 4 large pieces of cardboard to form a house using Gorilla tape. Cut out a door in the entrance leaving a headboard and sides for the kids to paint. I used an extra piece of cardboard to go under the entrance, in case any paint spilled.

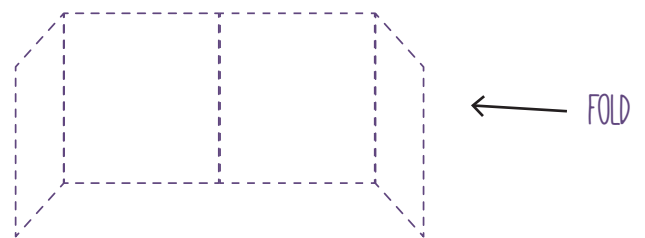
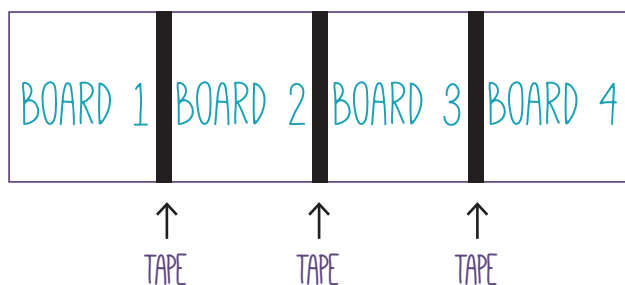

WITH THE STAFF THAT IS IN
MY HAND I WILL STRIKE THE WATER
OF THE NILE, AND IT WILL
BE CHANGED INTO BLOOD

EXODUS 7:17

WITH THE STAFF THAT IS IN
MY HAND I WILL STRIKE THE WATER
OF THE NILE, AND IT WILL
BE CHANGED INTO BLOOD

EXODUS 7:17

WITH THE STAFF THAT IS IN
MY HAND I WILL STRIKE THE WATER
OF THE NILE, AND IT WILL
BE CHANGED INTO BLOOD

EXODUS 7:17

WITH THE STAFF THAT IS IN
MY HAND I WILL STRIKE THE WATER
OF THE NILE, AND IT WILL
BE CHANGED INTO BLOOD

EXODUS 7:17