



THE TEMPLE WEEK 1



THE TEMPLE

THE TEMPLE

THE FIRST

FOCUS

1 KINGS 5:8-9, 6:7, 15, 18, 21, 29, 7:21, 25, 8:6, 10 & 29-30, 1 CHRONICLES 28:6 & 11, 2 CHRONICLES 4:1, 6, 19-20 & 5:13

King Solomon built the very first temple!

MATERIALS

The First picture

David and Solomon coloring page (1 per child)

The First Temple Blueprints coloring page (1 per child)

Trees, rubberbands and sea (1 set per child)

MegaBlocs to build the temple and accessories

The Temple blueprints with accessories

Flashlight

Crayons, yellow markers/highlighters, scissors & tape

ACTIVITIES

1. INTRODUCTION

TALK: Ask the children if they know about the first temple built by King Solomon!

ACTIVITY: Show children The First picture and hang nearby for them to see.

2. SOLOMON'S JOB

TALK: David wanted to build God a temple, but God said he wanted David's son Solomon to build it instead!

ACTIVITY: Color the coloring page of David and Solomon talking about the temple.

CORRESPONDING VERSE

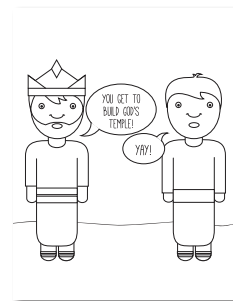
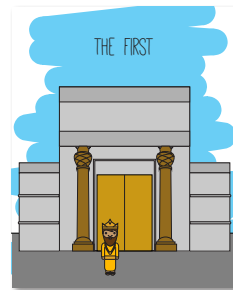

HE SAID TO ME: 'SOLOMON YOUR SON IS THE ONE WHO WILL BUILD MY HOUSE'

1 CHRONICLES 28:6

ACTIVITIES

3. A PLAN

TALK: Solomon knew what he wanted God's temple to look like! He had blueprints!

ACTIVITY: Have the children trace the blueprints.

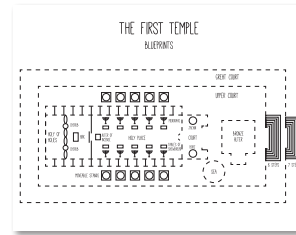

CORRESPONDING VERSE

THEN DAVID GAVE HIS SON SOLOMON THE PLANS FOR THE PORTICO OF THE TEMPLE, ITS BUILDINGS, ITS STOREROOMS, ITS UPPER PARTS, ITS INNER ROOMS AND THE PLACE OF ATONEMENT.

1 CHRONICLES 28:11

4. WOOD

TALK: Solomon knew what he wanted to build, and now he needed to start gathering materials to build it! He asked the king of Tyre for wood and the king said yes! They chopped down trees, made them into rafts and floated them down the sea for Solomon to pick up!

ACTIVITY: Have the children gather the popsicle sticks, bundle them together, float them down the sea then collect them on the other side!



PROVIDING THE CEDAR AND JUNIPER LOGS. MY MEN WILL HAUL THEM DOWN FROM LEBANON TO THE MEDITERRANEAN SEA, AND I WILL FLOAT THEM AS RAFTS BY SEA TO THE PLACE YOU SPECIFY.

1 KINGS 5:8-9

5. ROCKS

TALK: Solomon had wood, and now he needed rocks! He did not want the rocks to be cut near the temple, he wanted to bring them shaped and ready! So they were cut at the quarry!

ACTIVITY: Have the children grab one block at a time from the stack of MegaBlocks. Then use the large template to build the temple three blocks high!

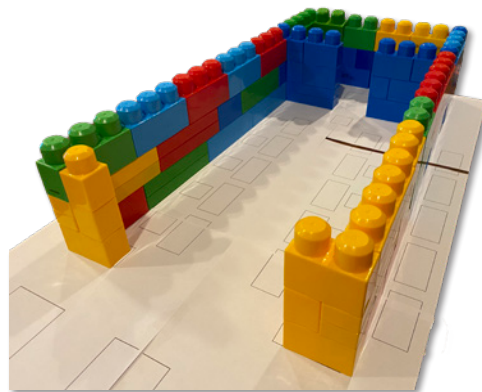

IN BUILDING THE TEMPLE, ONLY BLOCKS DRESSED AT THE QUARRY WERE USED, AND NO HAMMER, CHISEL OR ANY OTHER IRON TOOL WAS HEARD AT THE TEMPLE SITE WHILE IT WAS BEING BUILT.

1 KINGS 6:7

ACTIVITIES

6. BUILDING

TALK: After they had the wood and the rocks they started to build! They used the rocks first, then they put wood on the inside of the temple so you could not see any rocks! After all the rocks were covered up, they put gold on all the wood!

ACTIVITY: Color the sticks yellow then tape the popsicle sticks to the inside of the temple!

7. DECORATIONS

TALK: After the temple was built they started to make it look pretty! They made palm trees, open flowers, cherubim and gourds on the walls!

ACTIVITY: Have the children follow the steps to draw a palm tree or flower. Then cut it out and tape it to the inside of the temple.

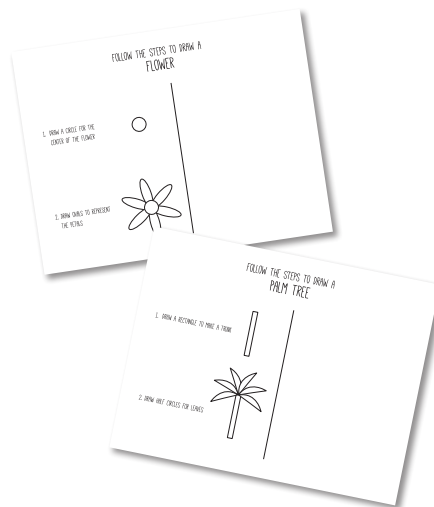

CORRESPONDING VERSE

HE LINED ITS INTERIOR WALLS WITH CEDAR BOARDS, PANELING THEM FROM THE FLOOR OF THE TEMPLE TO THE CEILING, AND COVERED THE FLOOR OF THE TEMPLE WITH PLANKS OF JUNIPER.

1 KINGS 6:15

SOLOMON COVERED THE INSIDE OF THE TEMPLE WITH PURE GOLD

1 KINGS 6:21

THE INSIDE OF THE TEMPLE WAS CEDAR, CARVED WITH GOURDS AND OPEN FLOWERS.

1 KINGS 6:18

ON THE WALLS ALL AROUND THE TEMPLE, IN BOTH THE INNER AND OUTER ROOMS, HE CARVED CHERUBIM, PALM TREES AND OPEN FLOWERS.

1 KINGS 6:29

ACTIVITIES

8. ARTICLES OF BRONZE

TALK: Solomon brought in an expert to make the pillars, alter, Sea, basins and utensils! He even cast two bronze pillars!

ACTIVITY: Have the children color and assemble the pillars, Sea, alter and moveable stands. Then place them in place.

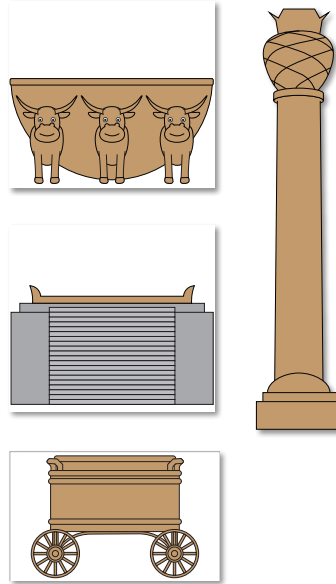

CORRESPONDING VERSE

1 KINGS 7:15 THE PILLAR TO THE SOUTH HE NAMED JAKIN AND THE ONE TO THE NORTH BOAZ

1 KINGS 7:21

THE SEA STOOD ON TWELVE BULLS, THREE FACING NORTH, THREE FACING WEST, THREE FACING SOUTH AND THREE FACING EAST.

1 KINGS 7:25

HE THEN MADE TEN BASINS FOR WASHING AND PLACED FIVE ON THE SOUTH SIDE AND FIVE ON THE NORTH. IN THEM THE THINGS TO BE USED FOR THE BURNT OFFERINGS WERE RINSED, BUT THE SEA WAS TO BE USED BY THE PRIESTS FOR WASHING.

2 CHRONICLES 4:6

HE MADE A BRONZE ALTER.

2 CHRONICLES 4:1

9. ARTICLES OF GOLD

TALK: Solomon had 10 lampstands and 10 tables for inside the temple! There was also the alter of incense!

ACTIVITY: Color, assemble and place the lampstands, tables and alter of incense inside temple.



SOLOMON ALSO MADE ALL THE FURNISHINGS THAT WERE IN GOD'S TEMPLE: THE GOLDEN ALTER; THE TABLES ON WHICH WAS THE BREAD OF THE PRESENCE; THE LAMPSTANDS OF PURE GOLD

2 CHRONICLES 4:19-20

ACTIVITIES

10. THE ARK

TALK: After everything inside and outside the temple was ready, they placed the original Ark that Moses and the Israelites had built in the desert inside the temple! After they put it inside, God's glory filled the temple!

ACTIVITY: Place the ark in the temple then shine a light inside the temple.

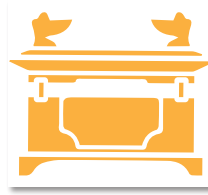

CORRESPONDING VERSE

THE PRIESTS THEN BROUGHT THE ARK OF THE LORD'S COVENANT TO ITS PLACE IN THE INNER SANCTUARY OF THE TEMPLE.

1 KINGS 8:6.

WHEN THE PRIESTS WITHDREW FROM THE HOLY PLACE, THE CLOUD FILLED THE TEMPLE OF THE LORD.

1 KINGS 8:10

11. ALL DONE

TALK: The temple was all done! It took 7 years, then they celebrated finishing for 7 days! Solomon dedicated the temple and prayed to God from it! He asked God that if anyone prayed in the direction of the temple, He would hear their prayer!

ACTIVITY: Sit down and pray in the direction of the temple.

MAY YOUR EYES BE OPEN TOWARD THIS TEMPLE NIGHT AND DAY, THIS PLACE OF WHICH YOU SAID, 'MY NAME SHALL BE THERE,' SO THAT YOU WILL HEAR THE PRAYER YOUR SERVANT PRAYS TOWARD THIS PLACE. HEAR THE SUPPLICATIONS OF YOUR SERVANT AND OF YOUR PEOPLE ISRAEL WHEN THEY PRAY TOWARD THIS PLACE. HEAR FROM HEAVEN, YOUR DWELLING PLACE, AND WHEN YOU HEAR, FORGIVE.

1 KINGS 8:29-30

12. PRAISE!

TALK: The people were so excited about the temple they started praising God and singing songs!

ACTIVITY: Have the children sing "He is good; his love endures forever."

OPTIONAL: Hand out each child a bible verse to take home.

HE SAID TO ME: 'SOLOMON
YOUR SON IS THE ONE
WHO WILL BUILD MY HOUSE'

1 CHRONICLES 28:6

THE SINGERS RAISED THEIR VOICES IN PRAISE TO THE LORD AND SANG: "HE IS GOOD; HIS LOVE ENDURES FOREVER."

2 CHRONICLES 5:13

THE FIRST

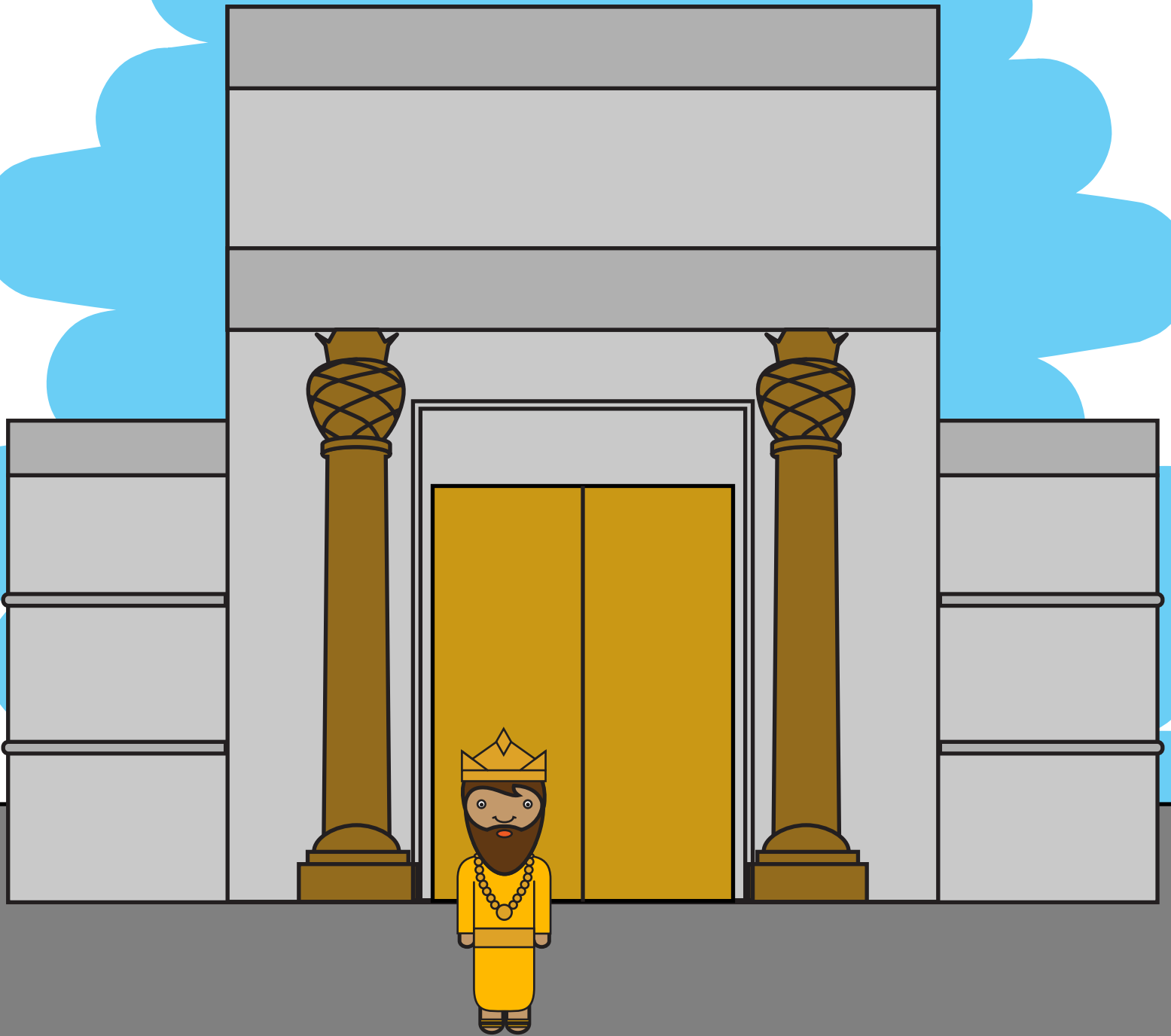

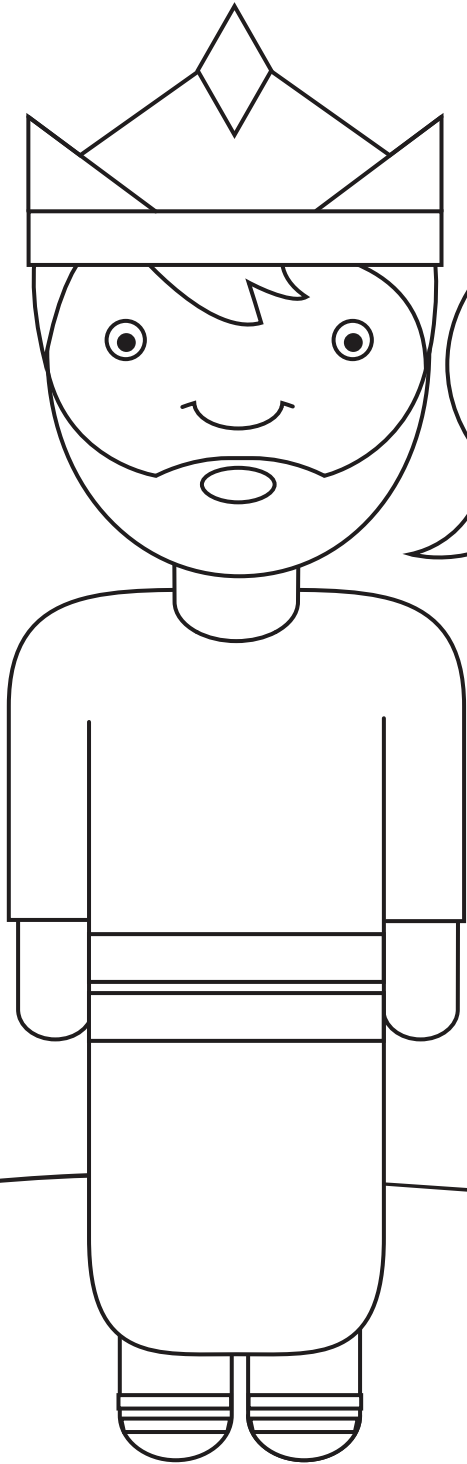

YOU GET TO
BUILD GOD'S
TEMPLE!

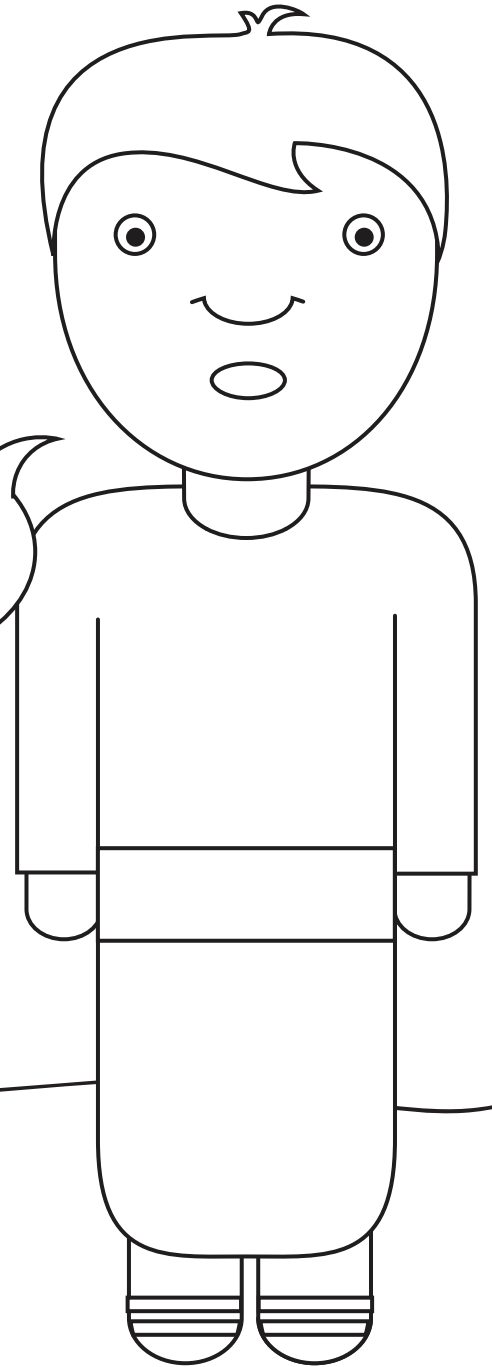

YAY!

THE FIRST TEMPLE

BLUEPRINTS

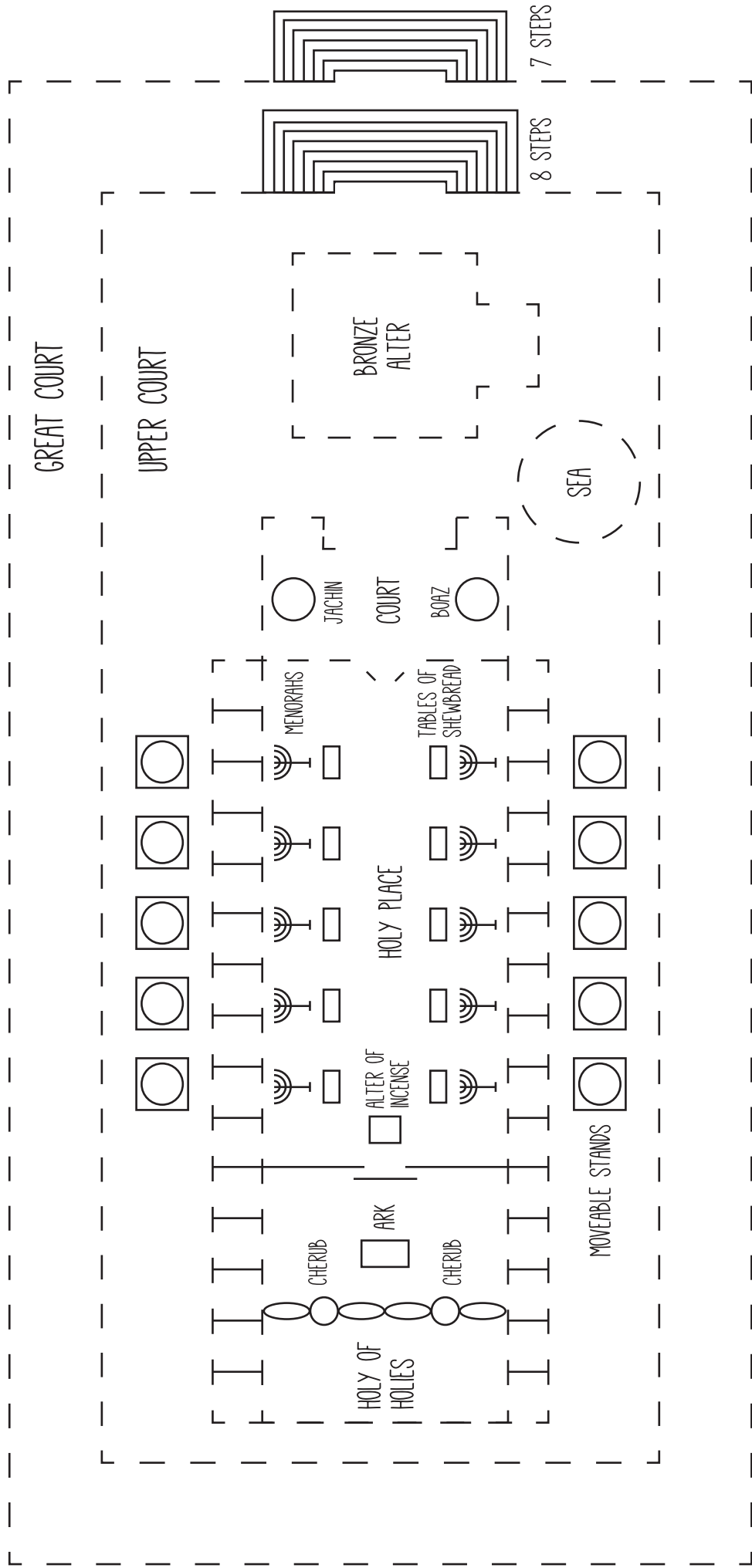

FOREST & SEA

I placed three craft sticks per child in a piece of green foam to represent a forest. They picked the sticks, placed the rubber bands around them, then placed them on one side of the water filled container. Each child took turns blowing the “raft” from one end to the other. I used different craft sticks to color and tape to the temple, since the first ones were wet.



THE CRAFT STICKS IN GREEN FOAM



LOGS

3 CRAFT
STICKS



2 SMALL
RUBBER BANDS

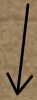

WRAP THE
RUBBER BANDS
AROUND THE
CRAFT STICKS

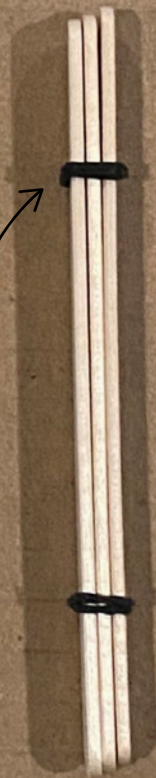
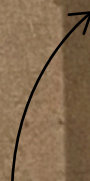

*IF THE CRAFT STICKS ARE TOO WET TO TAPE TO THE
TEMPLE, YOU CAN TRADE THEM FOR DRY CRAFT STICKS

ROCKS

I put all the MegaBloks together to form one block, so the children could take them out one by one.

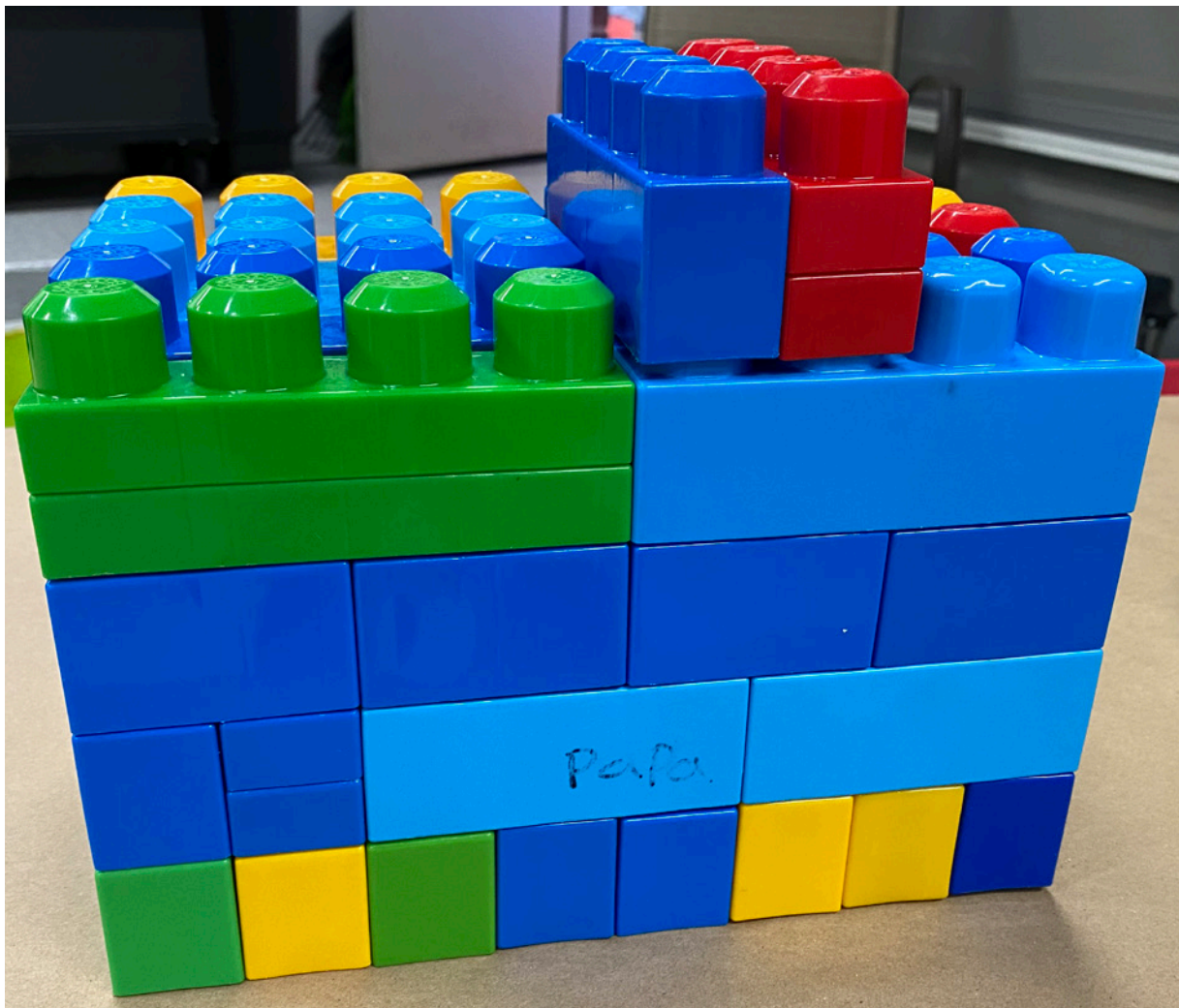

THE TEMPLE

I used MegaBloks to make the temple. Enough to make three blocks high all the way around the template. You can use the blueprint to know where to place the blocks for the first layer.

Print the template out to actual size and adjust when assembling it so that the shapes match the size of the blocks.

PRINT & ASSEMBLE



4X1 PIECE (ALL IN BLUE)



2X2 PIECE (ALL IN PURPLE)



2X1 PIECE (ALL IN YELLOW)

1X1 PIECE (ALL IN ORANGE)



1/2X1 PIECE (ALL IN RED)

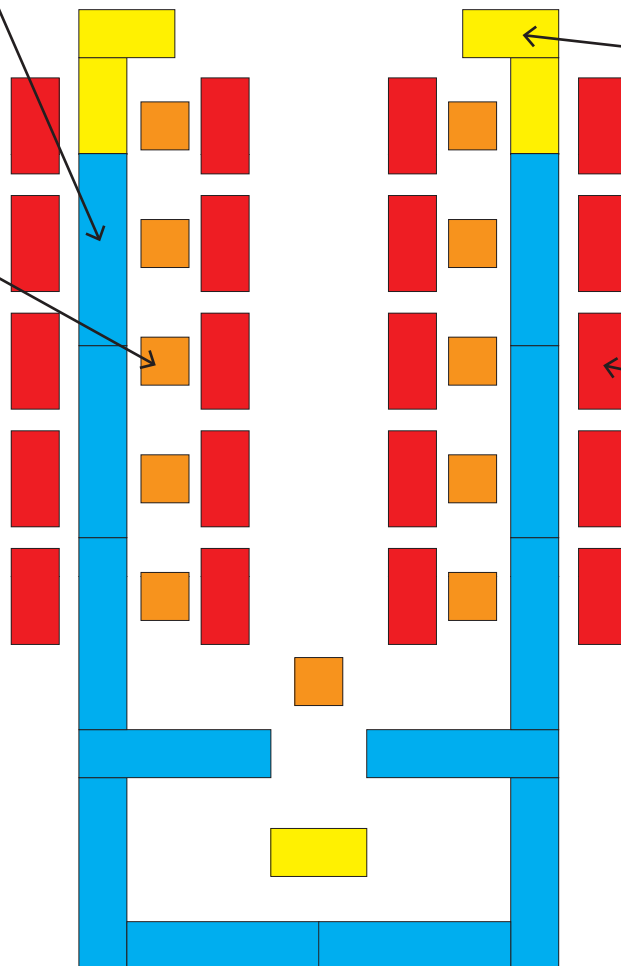

THE TEMPLE

After you do the first layer for the Temple, you can use other size blocks to make it three layers high.

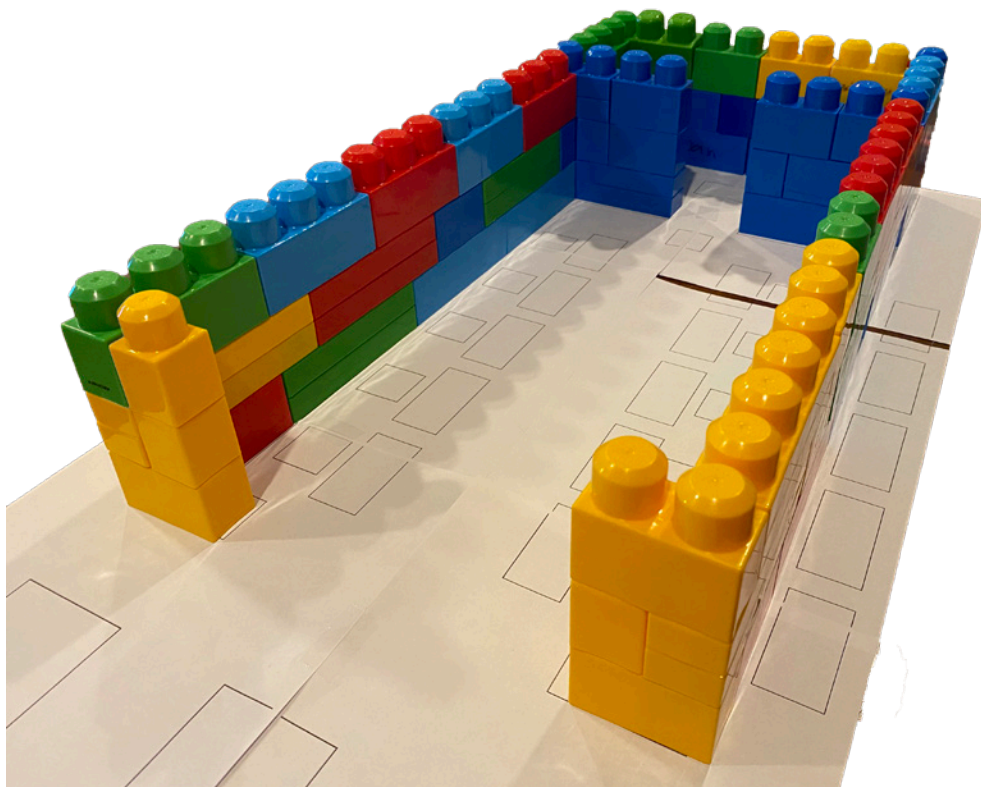
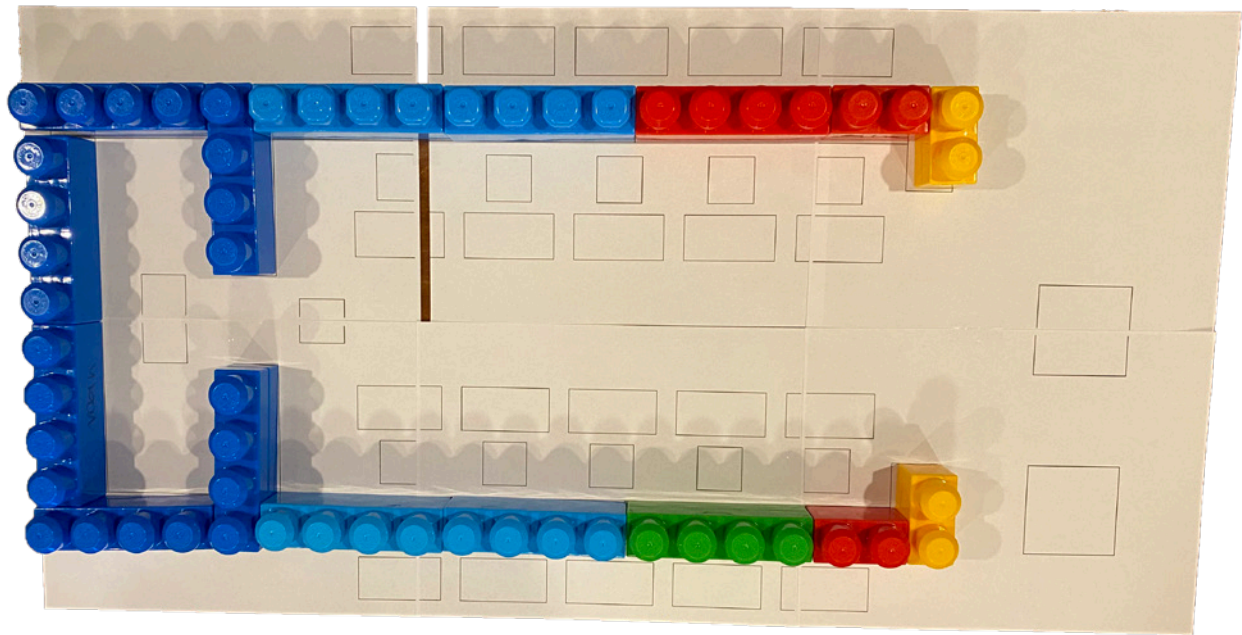

THE TEMPLE

After the Temple is completed you place the alters, Sea, tables, Menorahs, pillars and lastly the Ark in its place.

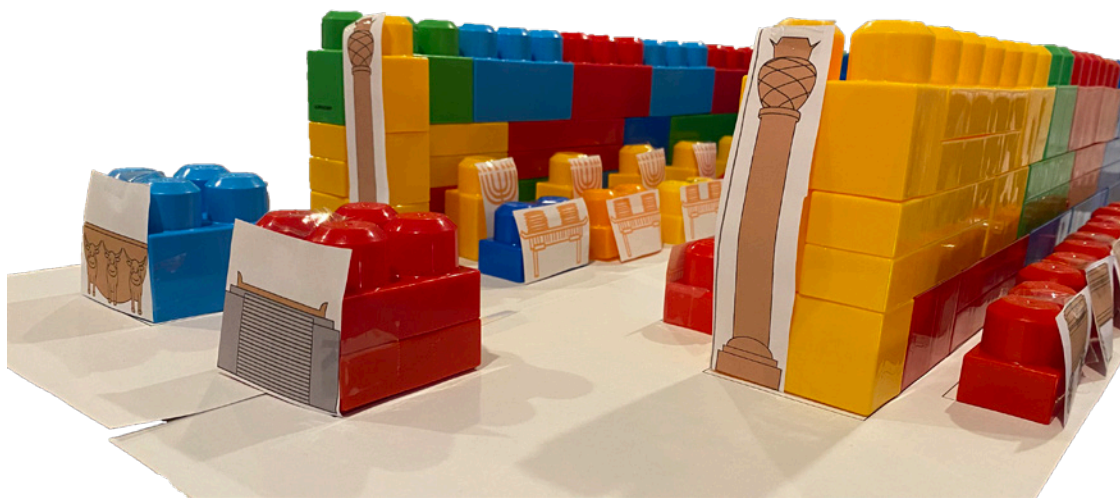
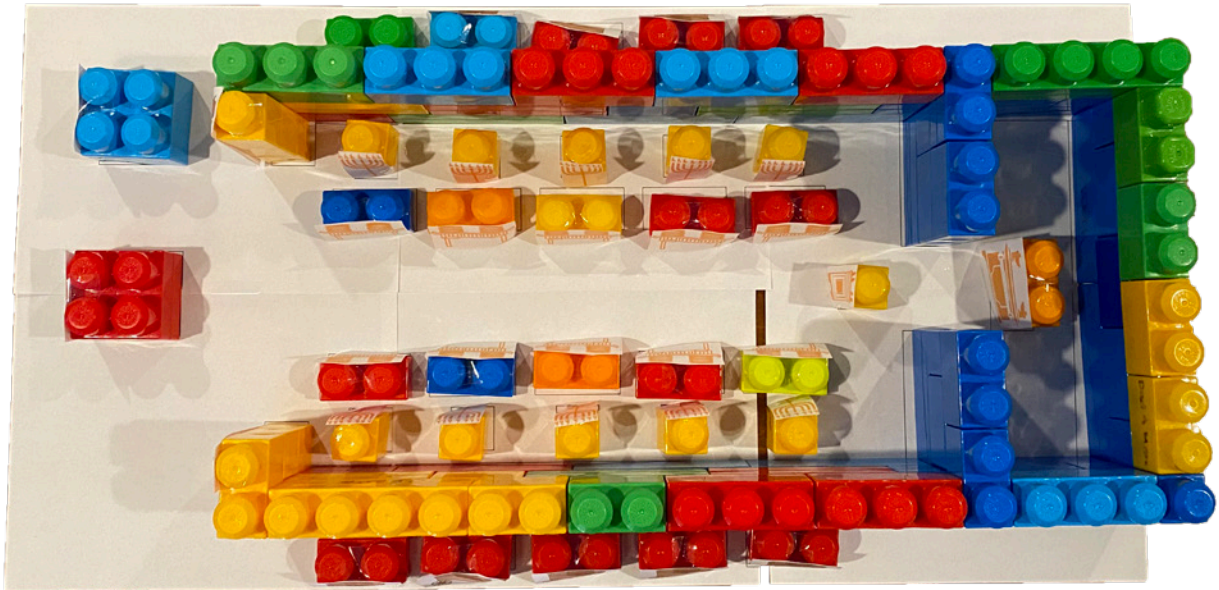

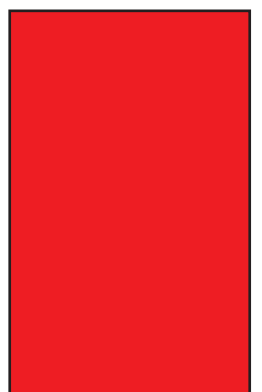
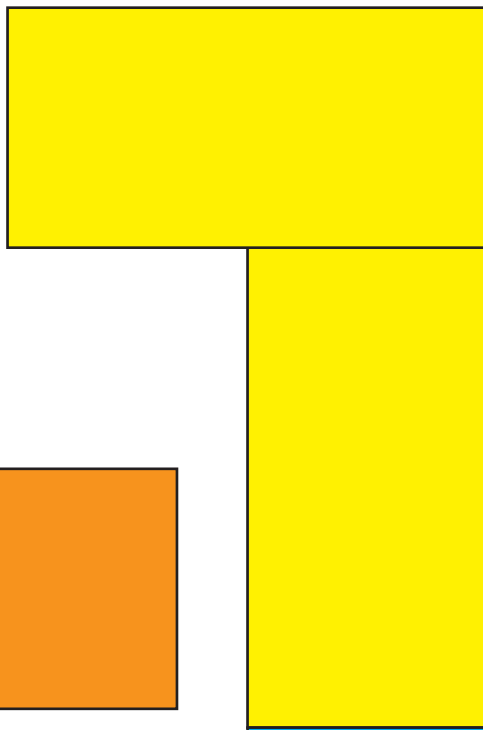
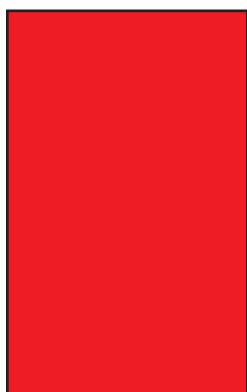
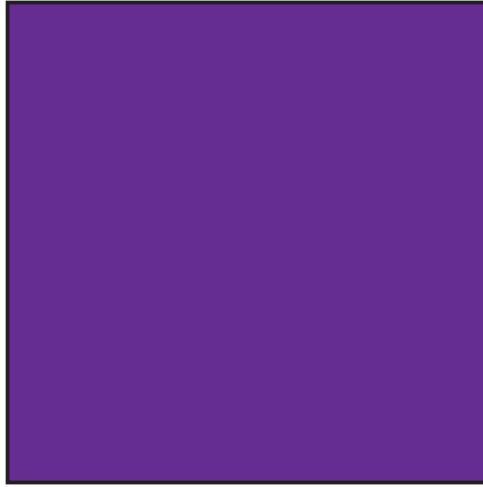

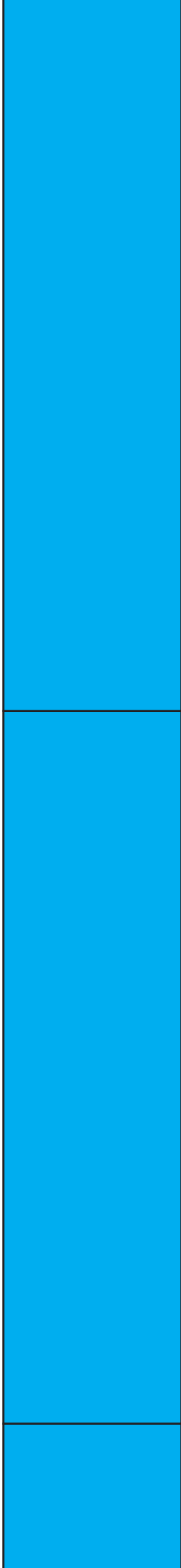
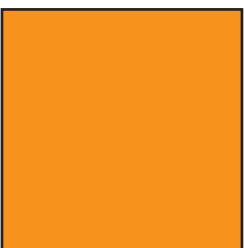
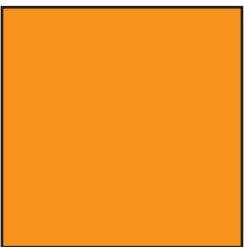
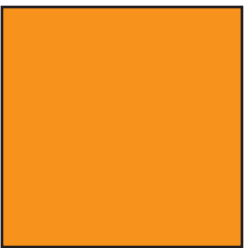
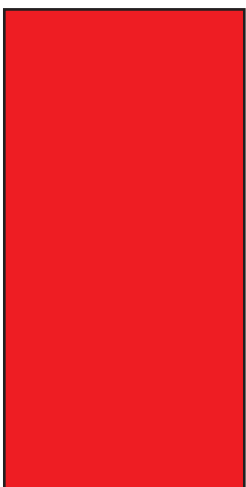
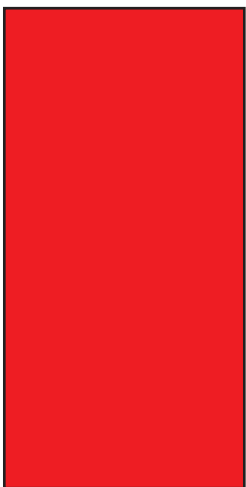
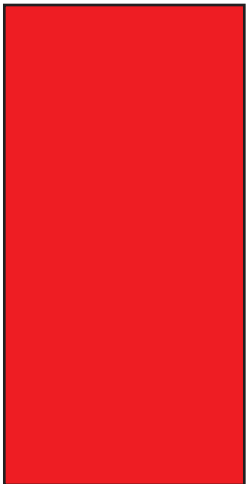

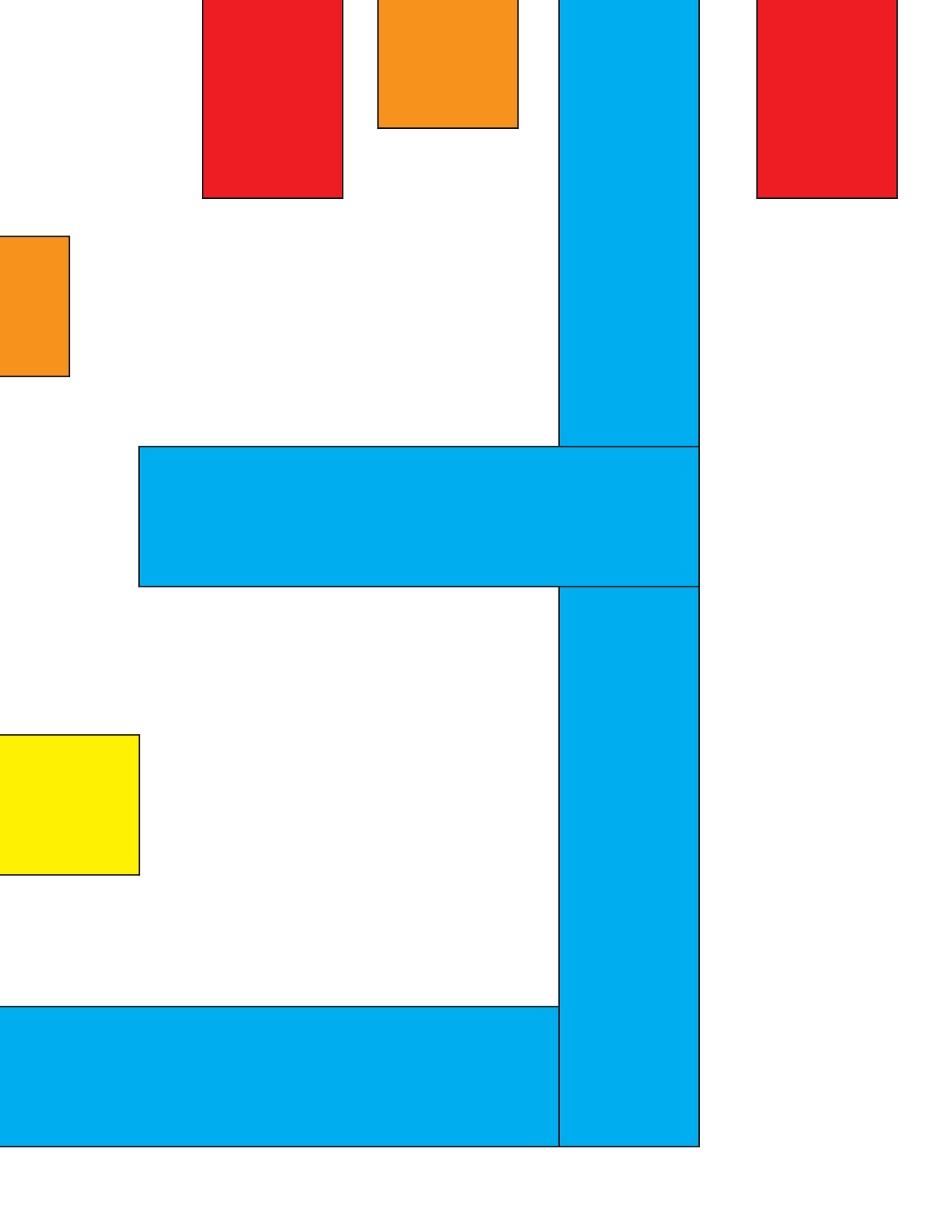

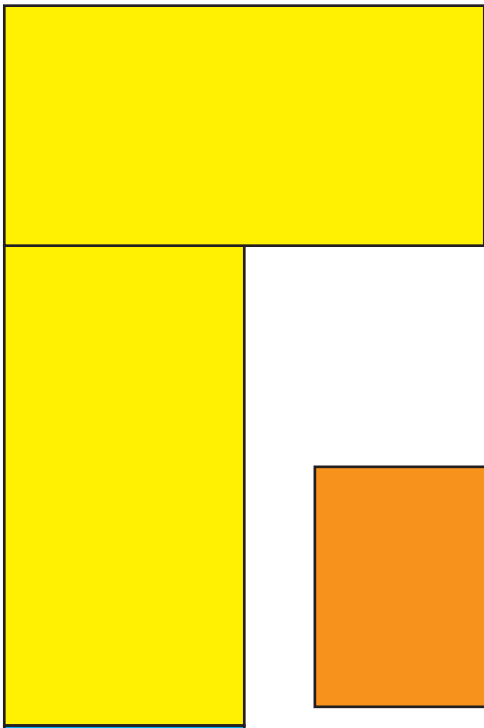
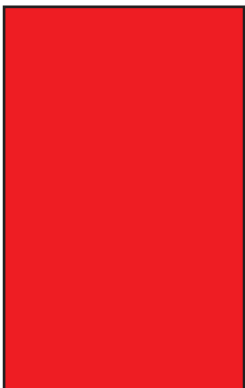

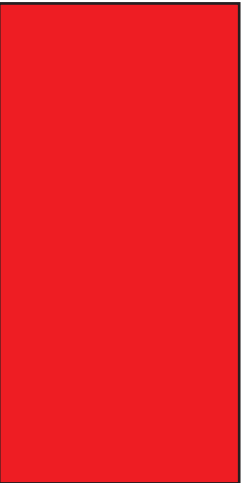
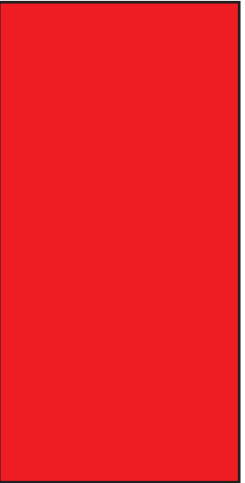

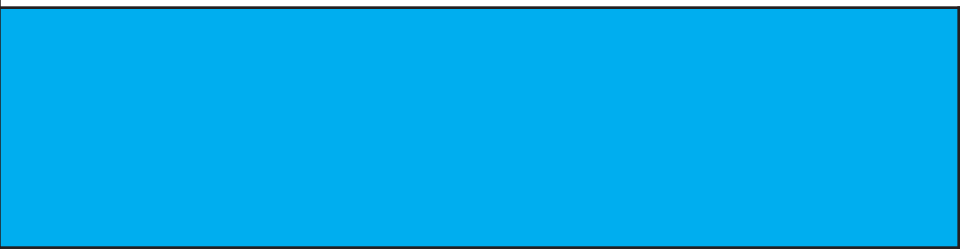
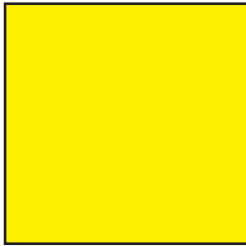
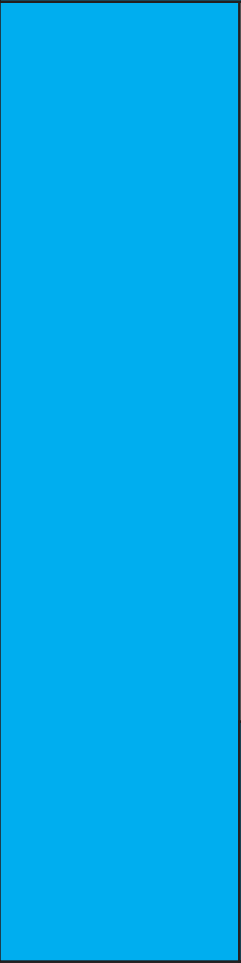
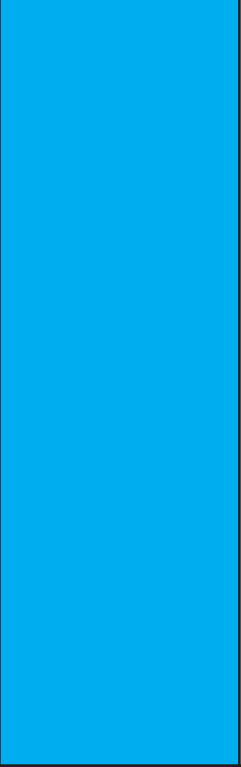
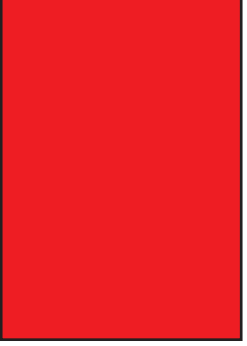

FOLLOW THE STEPS TO DRAW A FLOWER

1. DRAW A CIRCLE FOR THE
CENTER OF THE FLOWER

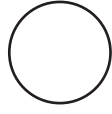

2. DRAW OVALS TO REPRESENT
THE PETALS

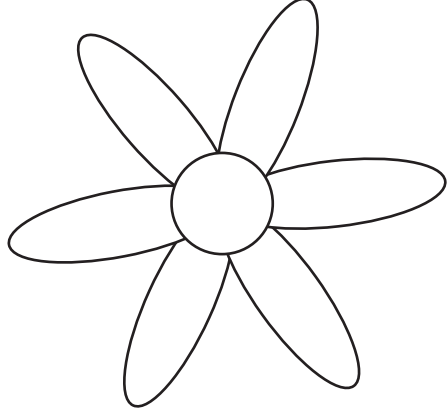

FOLLOW THE STEPS TO DRAW A PALM TREE

1. DRAW A RECTANGLE TO MAKE A TRUNK



2. DRAW HALF CIRCLES FOR LEAVES

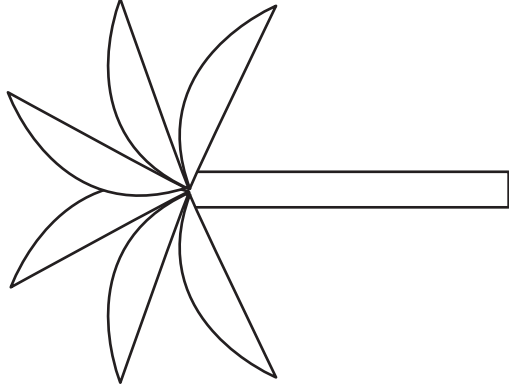

TEMPLE

PRINT & CUT OUT PIECES

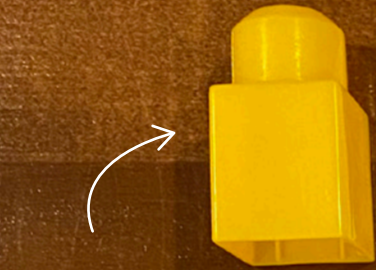

1X1 MEGA BLOK



ALTER OF INCENSE



MENORAH (X10)



1/2X1 MEGA BLOK



MOVEABLE STANDS (X10)



TABLE OF SHEWBREAD (X10)



2X1 MEGA BLOK

ARK



BRONZE ALTER

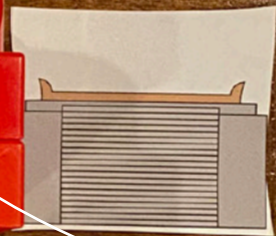
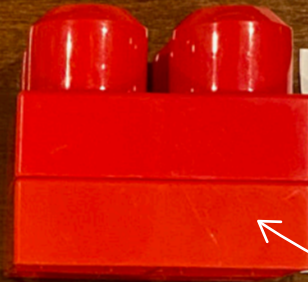

2X2 MEGA BLOK



SEA

TEMPLE

TAPE THE PIECES TO THE BLOCKS



ALTER OF
INCENSE



ARK



MENORAH
(X10)

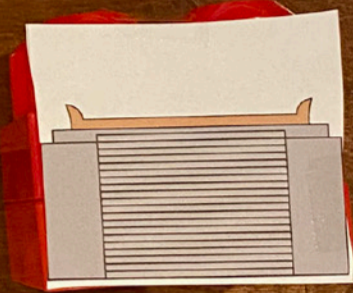

BRONZE
ALTER

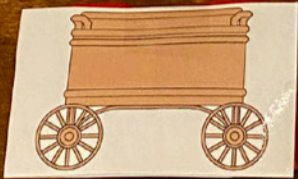

MOVEABLE STANDS
(X10)

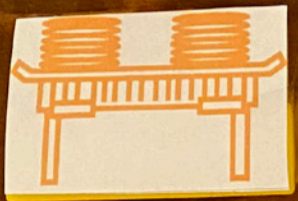
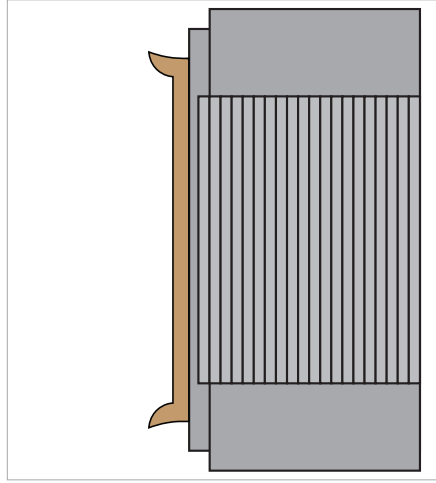

TABLE OF
SHEWBREAD
(X10)



SEA

BRONZE ALTER



SEA

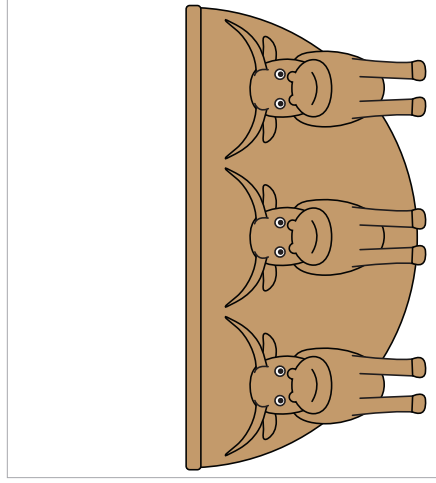

ARK

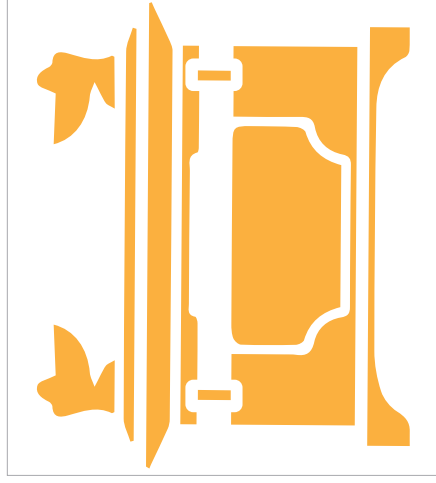

ALTER OF INCENSE



TABLE OF SHEWBREAD X10

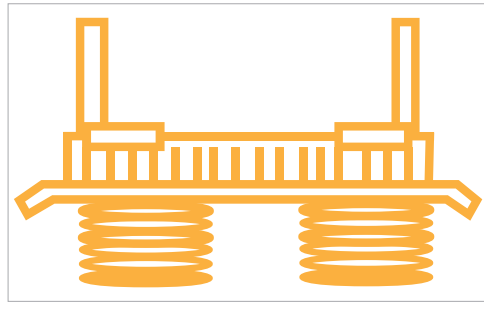
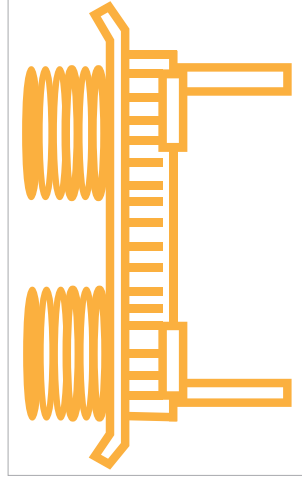
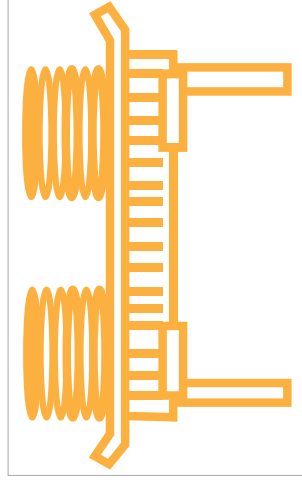
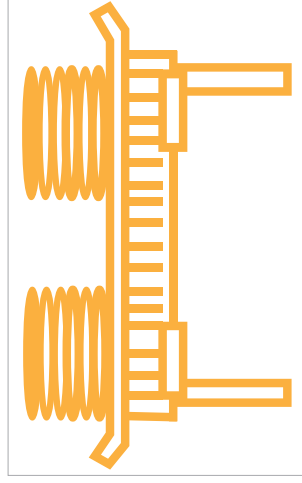
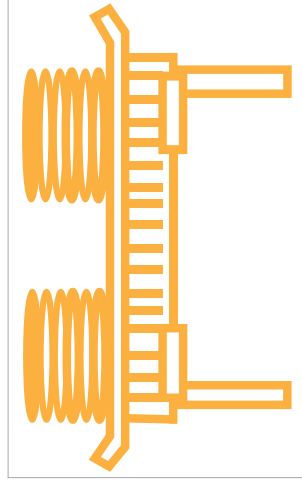
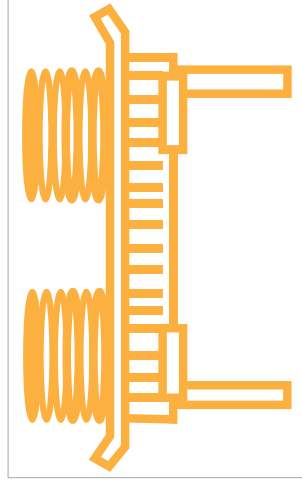
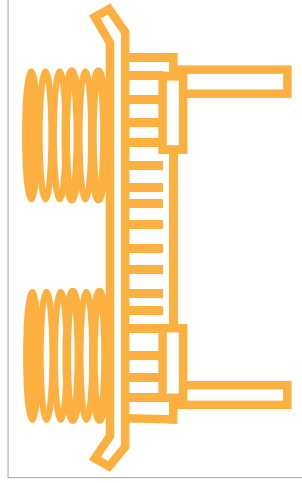
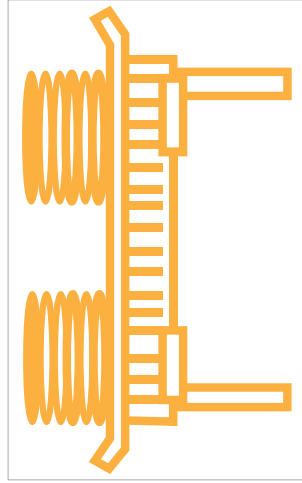
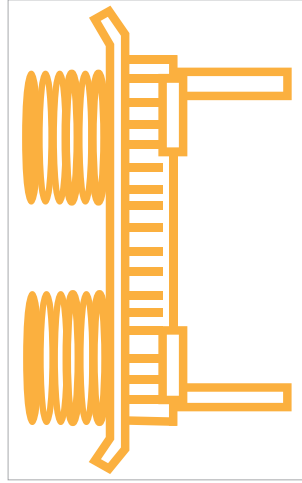
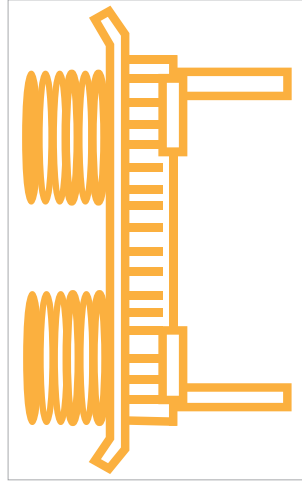

PILLARS X2

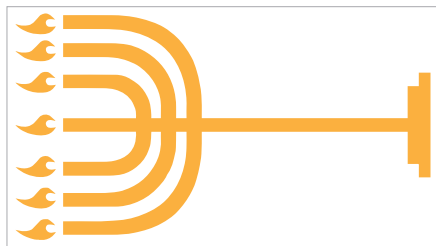
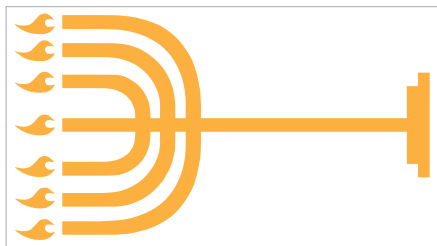
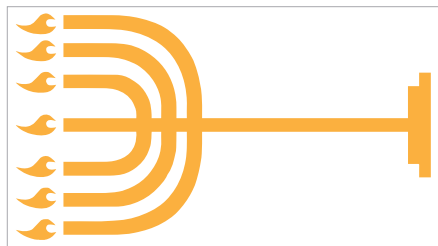
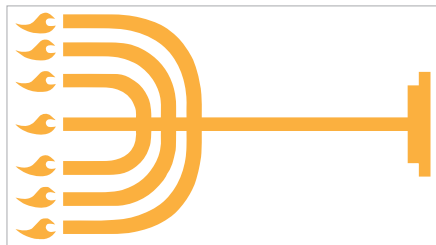
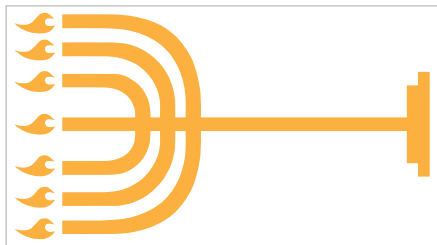
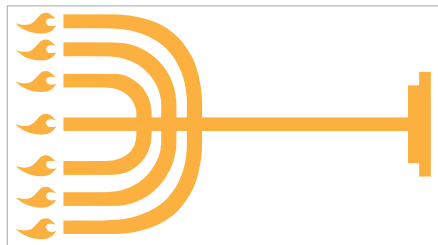
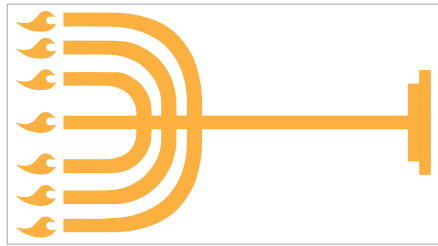
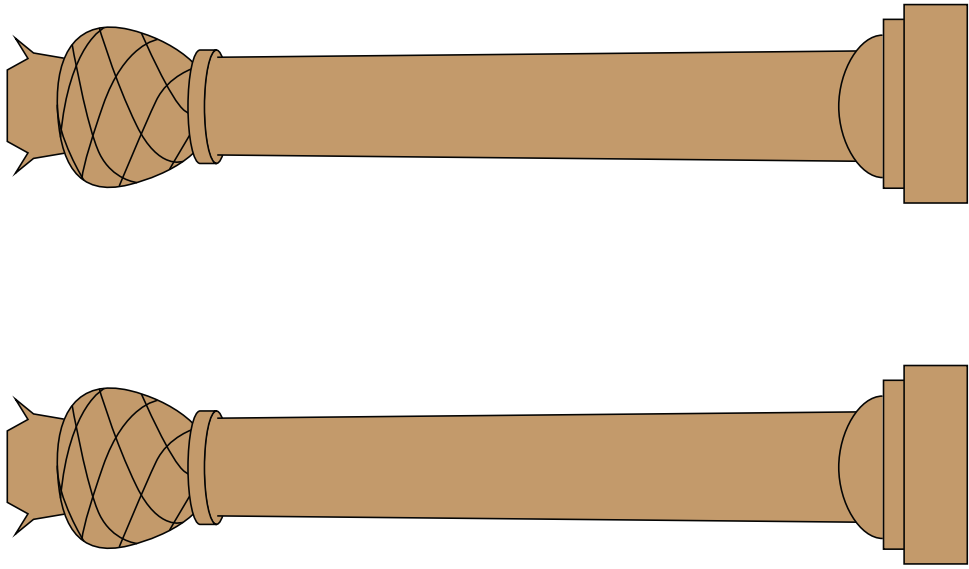

MENORAH X10

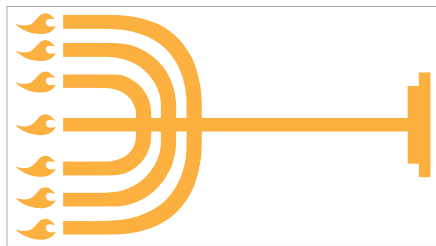
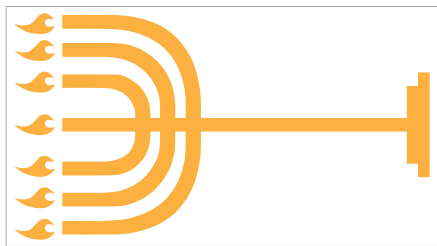
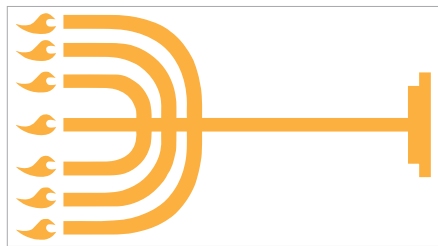

MOVEABLE STANDS X10

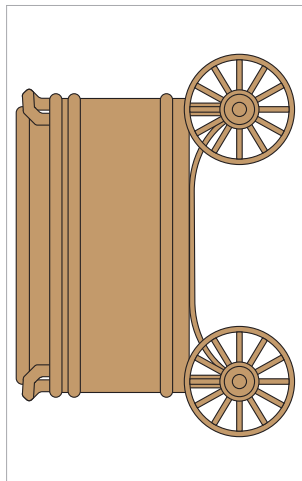
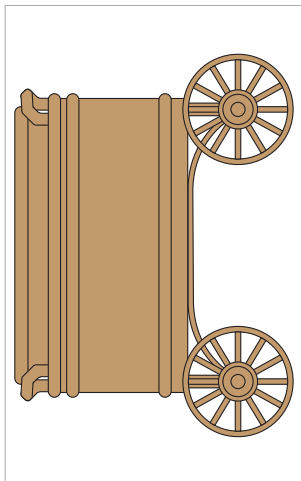
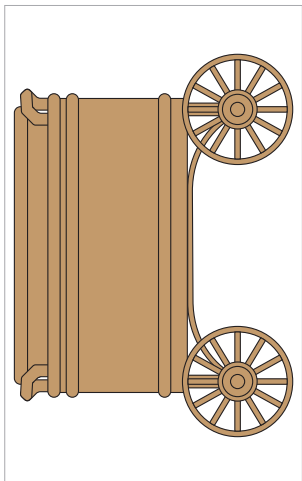
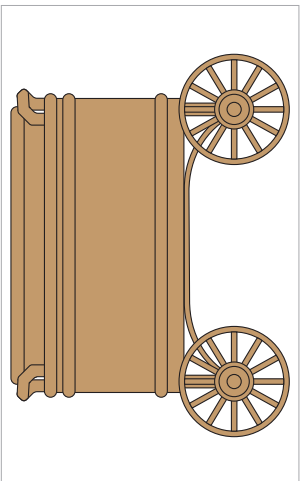
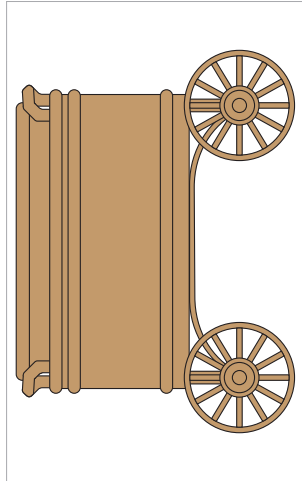
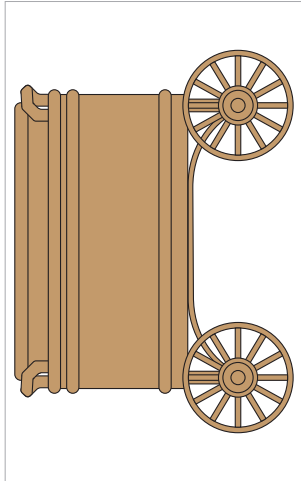
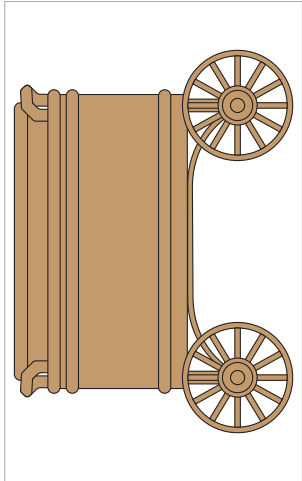
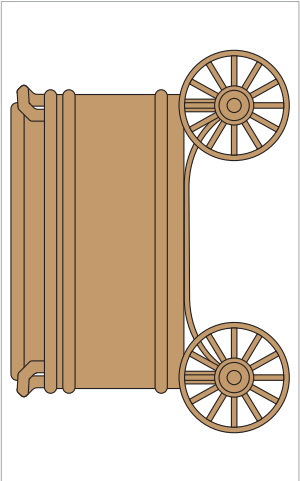
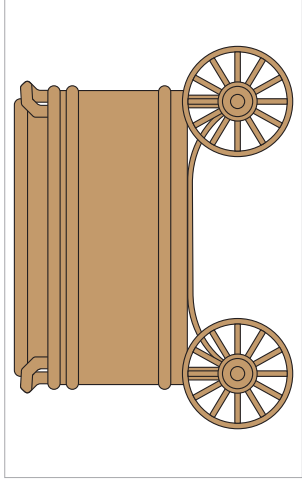
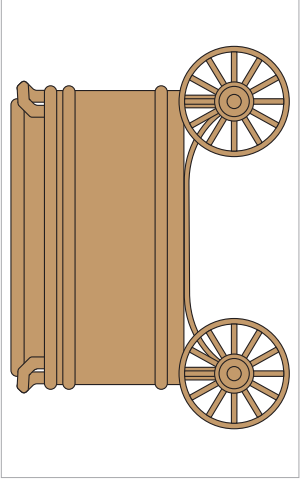

HE SAID TO ME: 'SOLOMON
YOUR SON IS THE ONE
WHO WILL BUILD MY HOUSE'

1 CHRONICLES 28:6

HE SAID TO ME: 'SOLOMON
YOUR SON IS THE ONE
WHO WILL BUILD MY HOUSE'

1 CHRONICLES 28:6

HE SAID TO ME: 'SOLOMON
YOUR SON IS THE ONE
WHO WILL BUILD MY HOUSE'

1 CHRONICLES 28:6

HE SAID TO ME: 'SOLOMON
YOUR SON IS THE ONE
WHO WILL BUILD MY HOUSE'

1 CHRONICLES 28:6