



# DREAMS WEEK 1



# DREAMS

## DREAMS

## PHARAOH'S DREAMS

### FOCUS

GENESIS 41:1-8, 14-17, 36 & 41-42

Pharaoh had two dreams! The first dream was about cows and the second grain! Both dreams meant the same thing! There would be 7 years of plenty followed by 7 years of famine!

### MATERIALS

Pharaoh's Dreams picture  
Pharaoh's Headress and ring pop (1 set per child)  
Cupbearer & Joseph *with chains* actors  
Prison  
7 fat & 7 skinny cows  
7 heads of good grain & 7 heads of bad grain  
Egypt model  
What Does the Dream Mean? coloring page (2 for Joseph + 2 per child)  
Crackers (7 per child) & a small cup *large enough to hold the 7 crackers*  
Crayons, glue, scissors & tape

## ACTIVITIES

### 1. INTRODUCTION

**TALK:** Ask the children if they know about Pharaoh's two dreams!

**ACTIVITY:** Show children the Pharaoh's Dreams picture and hang nearby for them to see.



## CORRESPONDING VERSE

### 2. PHARAOH & JOSEPH

**TALK:** Pharaoh was the king of Egypt! While Joseph, Jacob's son, was in prison, Pharaoh had a dream!

**ACTIVITY:** Help the children color and assemble the pharaoh hat and put on a signet ring (ring pop). Then take them to see the Joseph actor with **chains** in "**prison**".



WHEN TWO FULL YEARS HAD PASSED, PHARAOH HAD A DREAM.

GENESIS 41:1

## ACTIVITIES

### 3. 1ST DREAM

**TALK:** In Pharaoh's first dream there were 7 fat cows coming up out of the Nile river! Then 7 ugly and skinny cows came up out of the Nile river and ate the seven fat cows!

**ACTIVITY:** Have the children color and assemble the 7 fat cows, place them in the river in the **Egypt model**, then and have them come up out of the river and onto the land. Then have them assemble and color the 7 skinny cows, place them in the river, come up out of the river, and then eat the 7 fat cows!

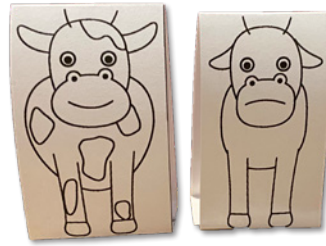

## CORRESPONDING VERSE

HE WAS STANDING BY THE NILE, WHEN OUT OF THE RIVER THERE CAME UP SEVEN COWS, SLEEK AND FAT, AND THEY GRAZED ALONG THE REEDS. AFTER THEM, SEVEN OTHER COWS, UGLY AND GAUNT, CAME UP OUT OF THE NILE AND STOOD BESIDE THOSE ON THE RIVERBANK. AND THE COWS THAT WERE UGLY AND GAUNT ATE UP THE SEVEN SLEEK, FAT COWS.

GENESIS 41:1-4

### 4. 2ND DREAM

**TALK:** Pharaoh had a second dream about grain! There were 7 heads of good grain growing on one stalk. Then 7 bad heads of grain spouted and swallowed up the 7 good heads of grain!

**ACTIVITY:** Have the children place the 7 good heads on the large stalk. Next have them add the 7 bad heads underneath it. Then take the good heads off the stalk and move the bad heads up.



HE FELL ASLEEP AGAIN AND HAD A SECOND DREAM: SEVEN HEADS OF GRAIN, HEALTHY AND GOOD, WERE GROWING ON A SINGLE STALK. AFTER THEM, SEVEN OTHER HEADS OF GRAIN SPROUTED—THIN AND SCORCHED BY THE EAST WIND. THE THIN HEADS OF GRAIN SWALLOWED UP THE SEVEN HEALTHY, FULL HEADS. THEN PHARAOH WOKE UP; IT HAD BEEN A DREAM.

GENESIS 41:5-7

## ACTIVITIES

### 5. WHAT DOES IT MEAN?

**TALK:** Pharaoh woke up and was troubled! He knew his dream had been important, but he did not know why! He sent for all the wise men in Egypt to come and tell him what his dream meant, but no one could tell him.

**ACTIVITY:** Have the children tell the two dreams to their parents, then ask them what it means. Then have the parent's tell them that they do not know what it means!

### 6. CUPBEARER

**TALK:** Pharaoh was sad, no one could tell him what his dream meant! Then his cupbearer remembered that when he had a dream and wanted to know what it meant, Joseph told him! So Pharaoh asked Joseph to come!

**ACTIVITY:** Have the cupbearer actor come and say, "Joseph can tell you what it means, but he's in prison!" Then have the children say, "Bring Joseph!"

### 7. JOSEPH

**TALK:** Joseph came to see Pharaoh and he told him his dreams so that Joseph could tell him what they meant!

**ACTIVITY:** Have the Joseph actor come forward, then have the children ask Joseph if he can tell them what his dream means. Then have Joseph say "I can't do it, but God can!"

## CORRESPONDING VERSE

IN THE MORNING HIS MIND WAS TROUBLED, SO HE SENT FOR ALL THE MAGICIANS AND WISE MEN OF EGYPT. PHARAOH TOLD THEM HIS DREAMS, BUT NO ONE COULD INTERPRET THEM FOR HIM.

GENESIS 41:8

SO PHARAOH SENT FOR JOSEPH, AND HE WAS QUICKLY BROUGHT FROM THE DUNGEON. WHEN HE SHAVED AND CHANGED HIS CLOTHES, HE CAME BEFORE PHARAOH.

GENESIS 41:14

PHARAOH SAID TO JOSEPH, "I HAD A DREAM, AND NO ONE CAN INTERPRET IT. BUT I HAVE HEARD IT SAID OF YOU THAT WHEN YOU HEAR A DREAM YOU CAN INTERPRET IT." "I CANNOT DO IT," JOSEPH REPLIED TO PHARAOH, "BUT GOD WILL GIVE PHARAOH THE ANSWER HE DESIRES."

GENESIS 41:15-16

## ACTIVITIES

### 8. BOTH DREAMS

**TALK:** Pharaoh told Joseph his dreams! The dream about the 7 fat and thin cows and the dream about the 7 good and bad heads of grain!

**ACTIVITY:** Have the children tell Joseph the dreams, while Joseph is drawing pictures in the “Dream” boxes on the paper. Then have the children repeat the drawings on their paper.



### 9. WHAT THEY MEAN

**TALK:** After Joseph heard all about the dreams, God helped him to figure out what it meant! The dreams both meant the same thing! 7 years of plenty followed by 7 years of famine!

**ACTIVITY:** Have the Joseph actor show his notes to the children and explain what the dreams meant! Then have the children write the interpretation down too!



### 10. COLLECT

**TALK:** Pharaoh was happy he knew what the dreams meant, but he needed to make sure his people could survive 7 years of plenty then 7 years of famine! Joseph told him to collect the extra food in the years of plenty and save it for the years of famine!

**ACTIVITY:** Have each child stand in a line. Tell them that it is year one of the plenty and give them 1 cracker. Have them take a step forward and give them a new cracker, representing year 2 of plenty. Do this for the 7 years with 7 crackers. Then explain that it is now year 1 of the famine and have them give you back a cracker. Repeat this activity until it has been 7 years of famine, and explain that because they collected their crackers, they could survive the 7 years of famine!

## CORRESPONDING VERSE

THEN PHARAOH SAID TO JOSEPH, “IN MY DREAM..”  
GENESIS 41:17

THEN JOSEPH SAID TO PHARAOH, “THE DREAMS OF PHARAOH ARE ONE AND THE SAME. GOD HAS REVEALED TO PHARAOH WHAT HE IS ABOUT TO DO. THE SEVEN GOOD COWS ARE SEVEN YEARS, AND THE SEVEN GOOD HEADS OF GRAIN ARE SEVEN YEARS; IT IS ONE AND THE SAME DREAM. THE SEVEN LEAN, UGLY COWS THAT CAME UP AFTERWARD ARE SEVEN YEARS, AND SO ARE THE SEVEN WORTHLESS HEADS OF GRAIN SCORCHED BY THE EAST WIND: THEY ARE SEVEN YEARS OF FAMINE.”

GENESIS 41:25-27

“THIS FOOD SHOULD BE HELD IN RESERVE FOR THE COUNTRY, TO BE USED DURING THE SEVEN YEARS OF FAMINE THAT WILL COME UPON EGYPT, SO THAT THE COUNTRY MAY NOT BE RUINED BY THE FAMINE.”

GENESIS 41:36

## ACTIVITIES

### 11. PROMOTED

**TALK:** Pharaoh liked Joseph's plan and made him second in charge of Egypt! He even gave him his signet ring to show that he was in charge!

**ACTIVITY:** Have children take off their ring and give it to Joseph!

**OPTIONAL:** Hand out each child a bible verse to take home.

## CORRESPONDING VERSE

SO PHARAOH SAID TO JOSEPH, "I HEREBY PUT YOU IN CHARGE OF THE WHOLE LAND OF EGYPT." THEN PHARAOH TOOK HIS SIGNET RING FROM HIS FINGER AND PUT IT ON JOSEPH'S FINGER.

GENESIS 41:41-42

THEN PHARAOH SAID  
TO JOSEPH,  
"IN MY DREAM.."

GENESIS 41:17

# PHARAOH'S DREAMS

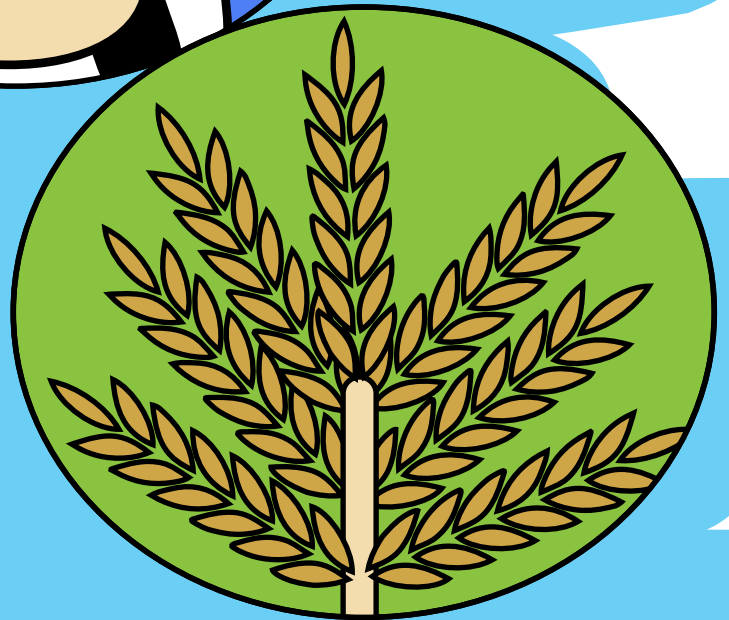

# HEADRESS

PRINT & CUT OUT

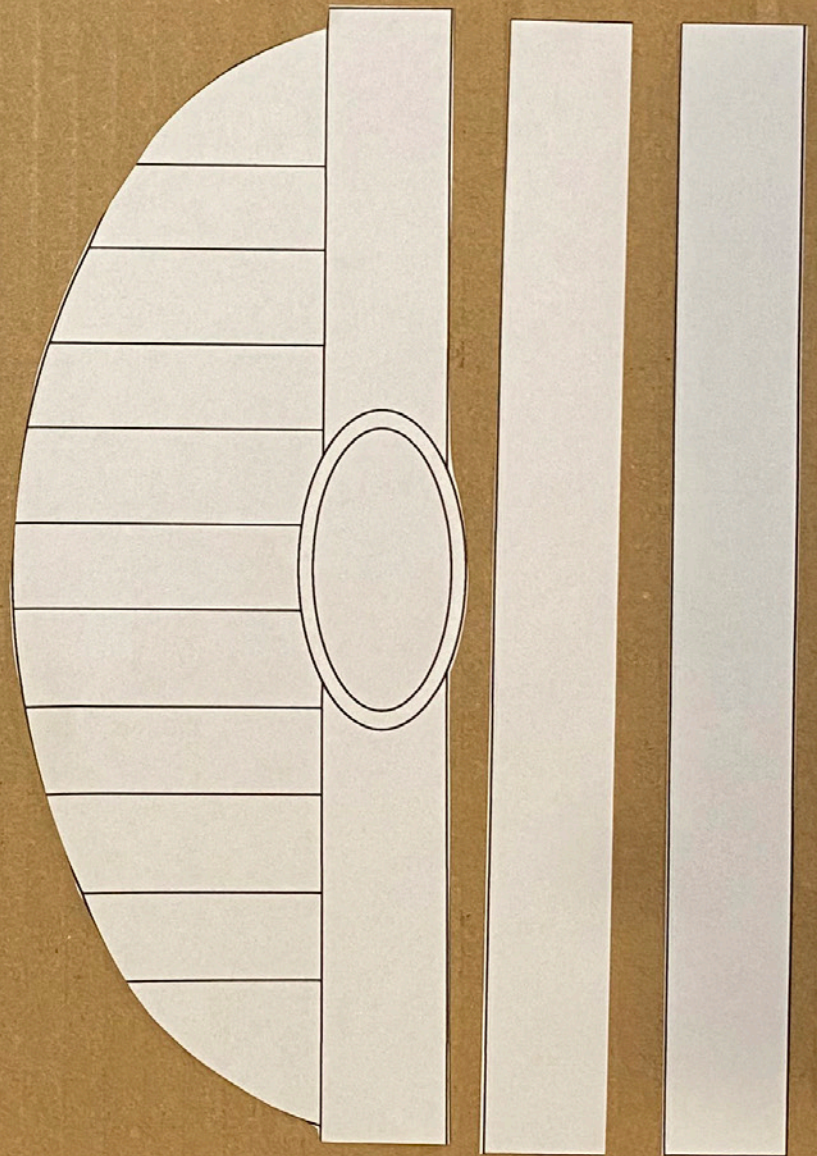
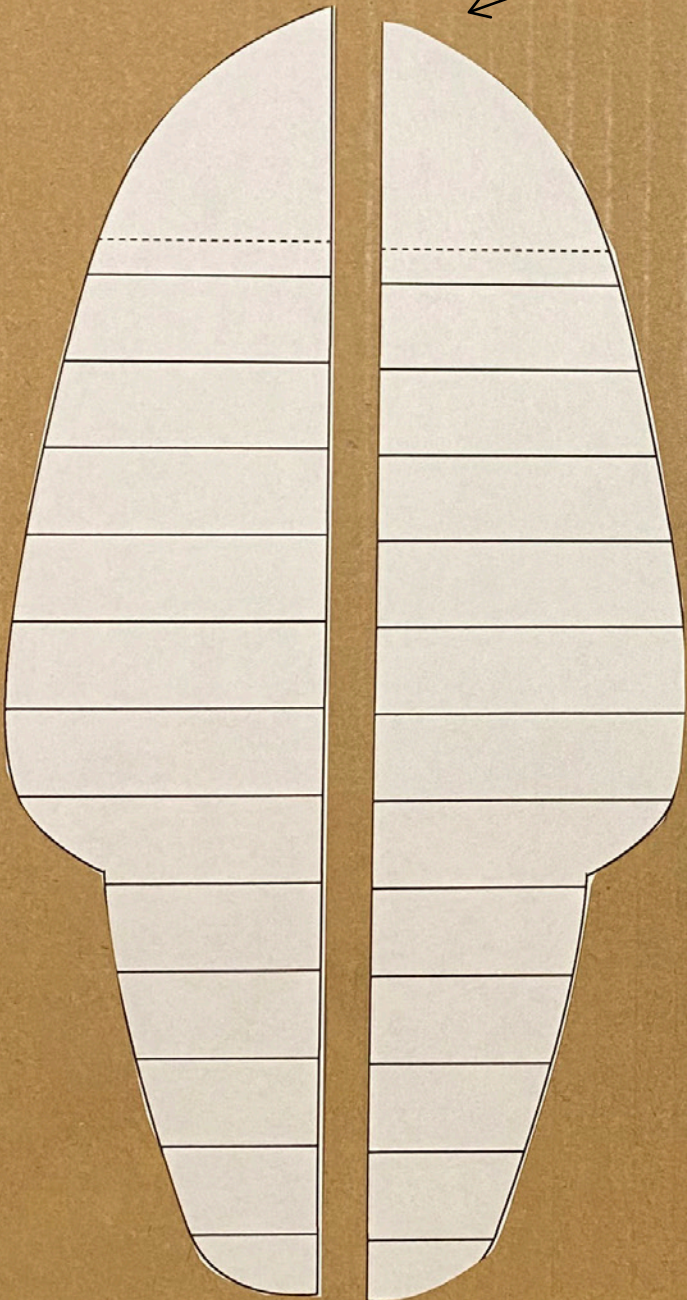
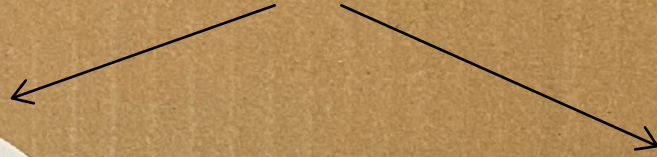



# HEADRESS

LAY THE STRIP  
DOWN FIRST, THEN  
THE SIDE LAPPETS

STAPLE THEM BOTH  
TO THE FRONT

STAPLE THE ENDS TOGETHER TO  
FIT THE CHILD'S HEAD

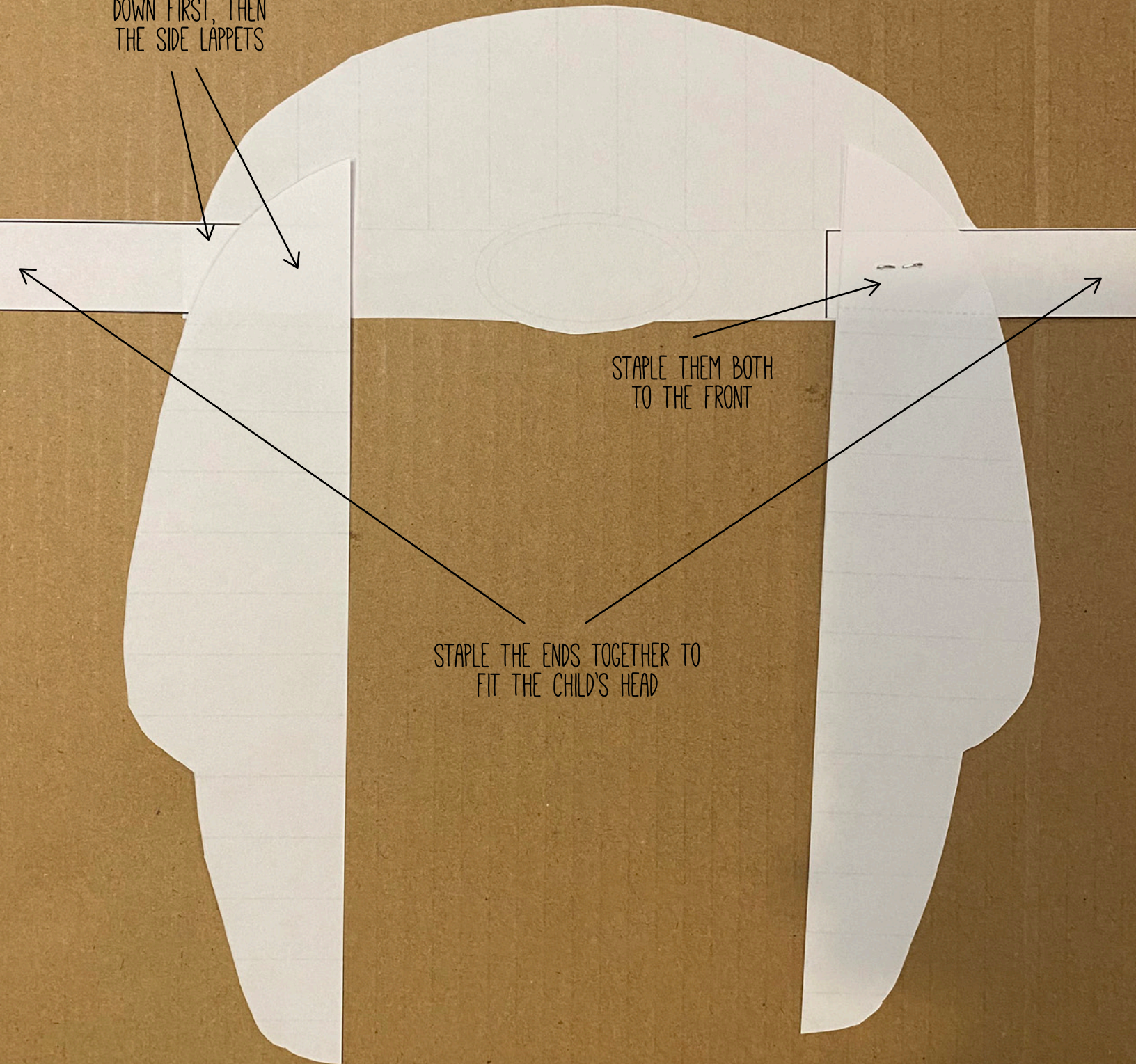

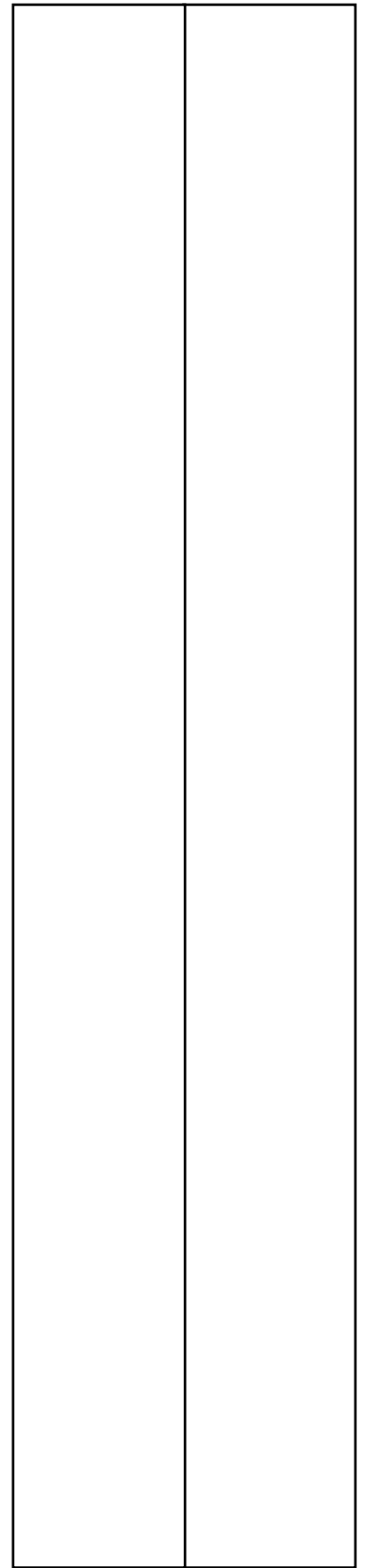
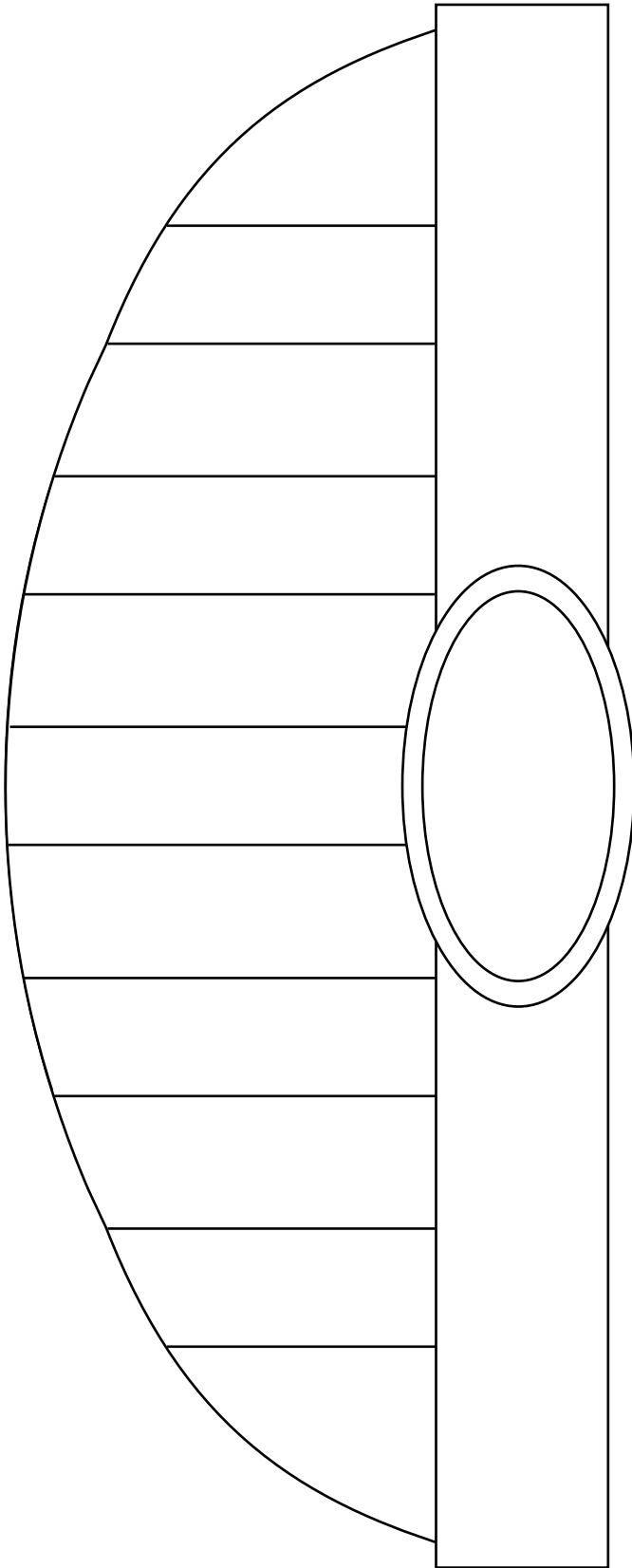

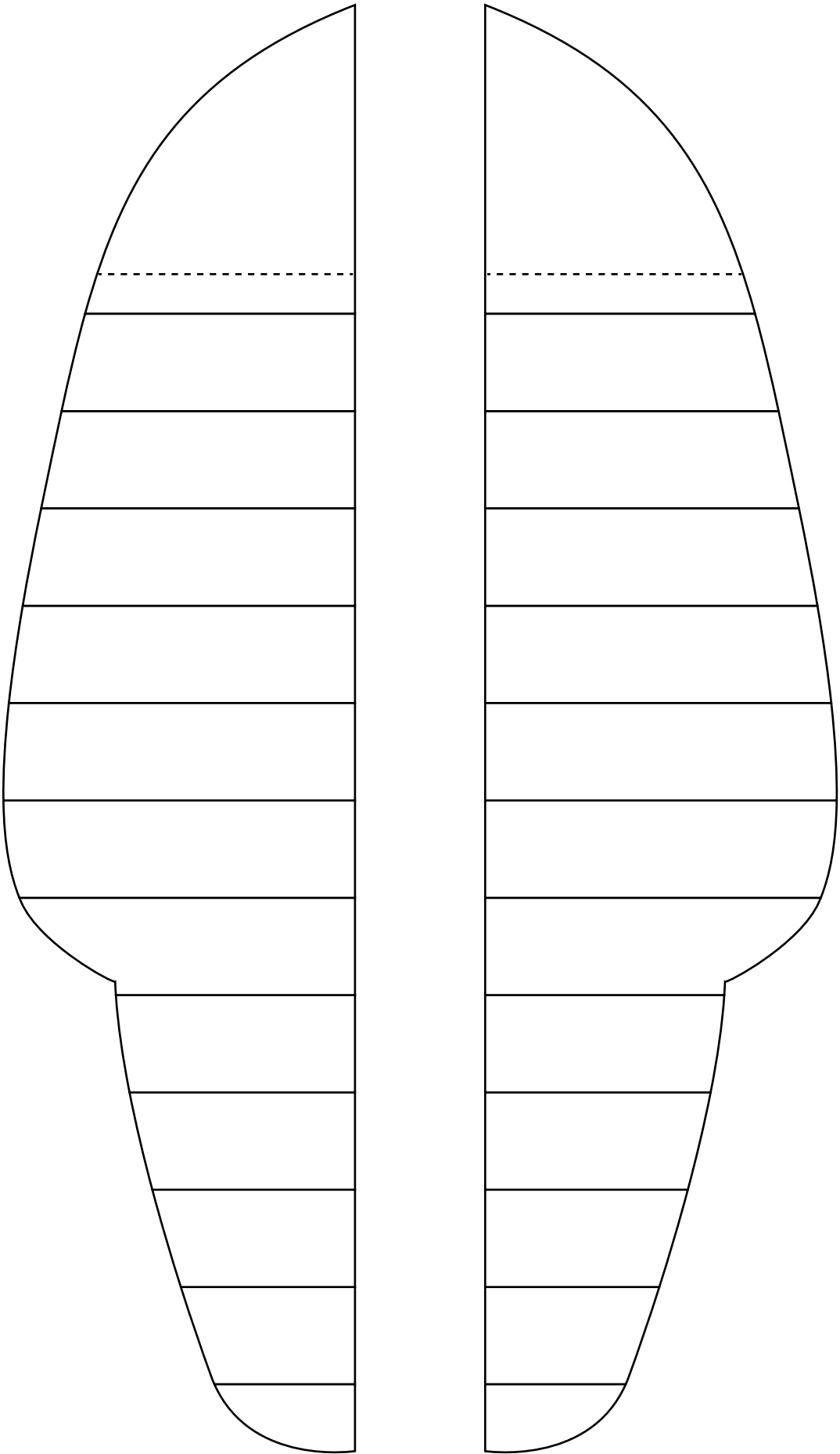

# PRISION

Using Gorilla Tape, I taped two large pieces of cardboard together. Then I cut out bars for the window and drew large rocks on the outside with a King Size Sharpie.



# CHAINS

CUT OUT 7-11 1" STRIPS OF BLACK CONSTRUCTION PAPER

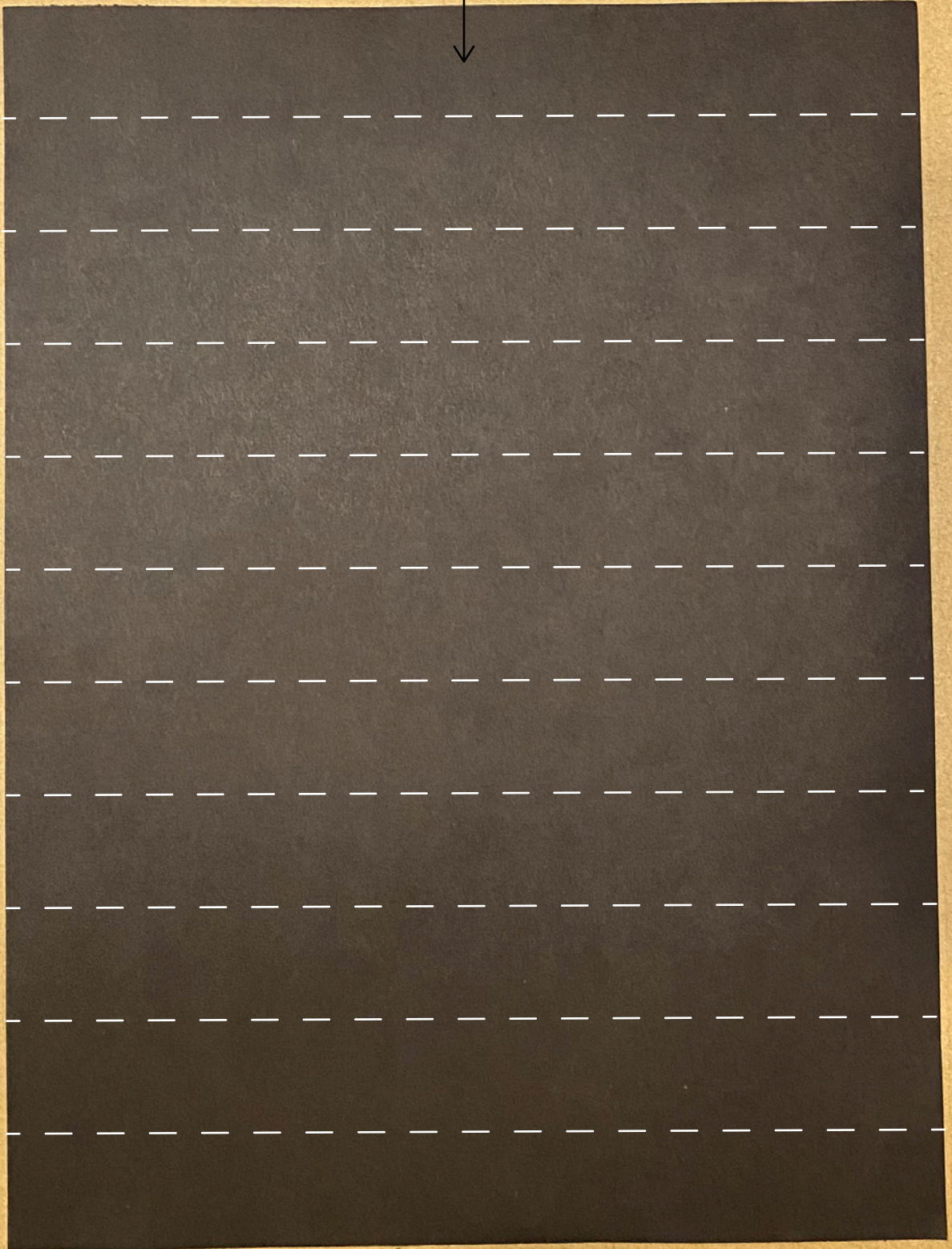

# CHAINS

WRAP THE STRIPS THROUGH EACH OTHER &  
STAPLE TOGETHER TO FORM A CHAIN

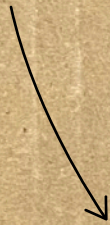

# CHAINS



# LARGE MODEL OF EGYPT

For large model of Egypt I used cedar pickets and 4" PVC pipe.

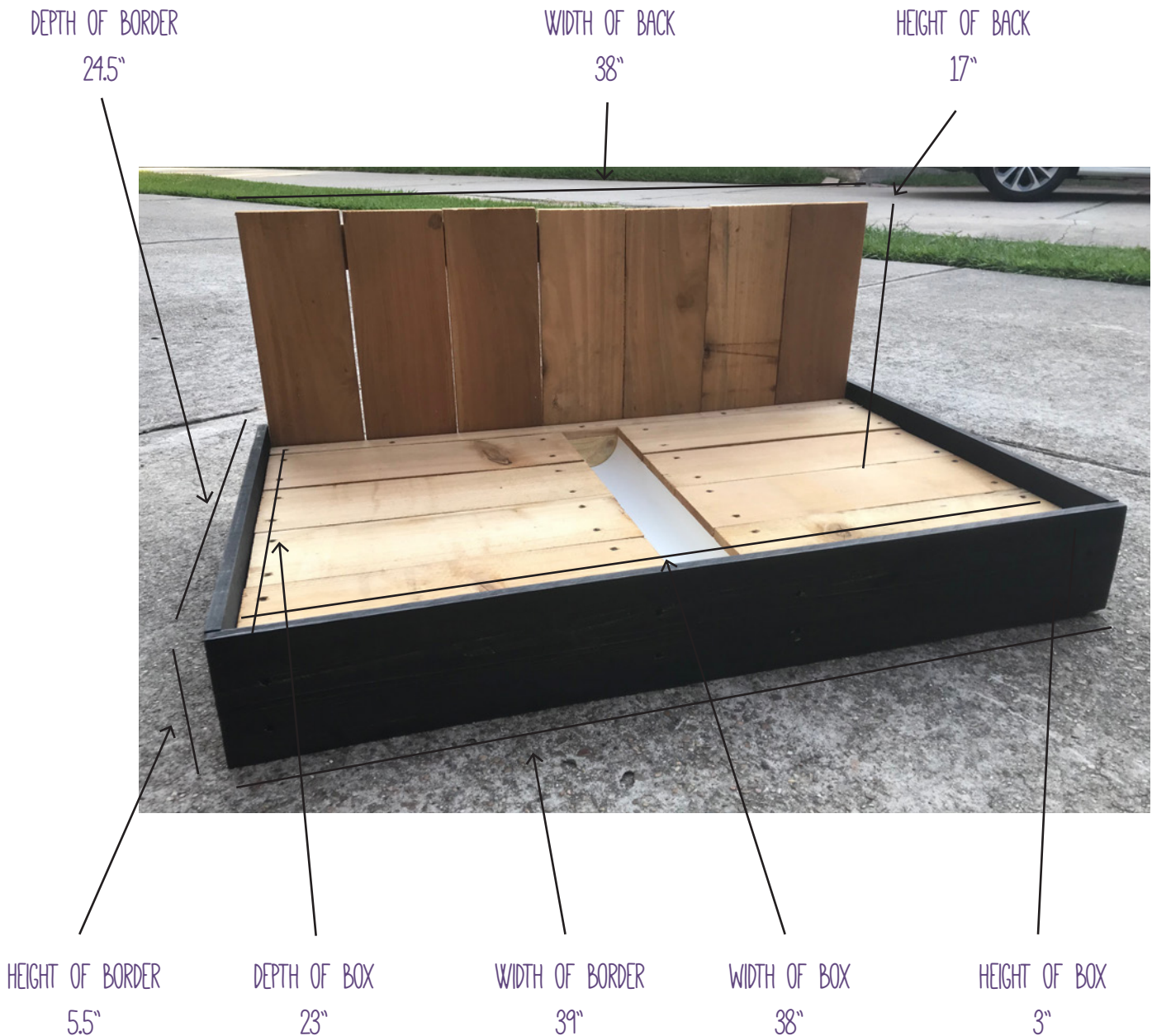



# LARGE MODEL OF EGYPT

I placed 2 8.5"x11" galvanized steel sheets on the front of the model (one on either side). This allowed the decorations to stand upright and become secure on the model. I cut the green and tan felt to size then spray and hot glue gunned the felt on the steel sheets and wood. I painted the wood around the pipe blue to match the painting and added trees and decorations around the model to look more realistic.

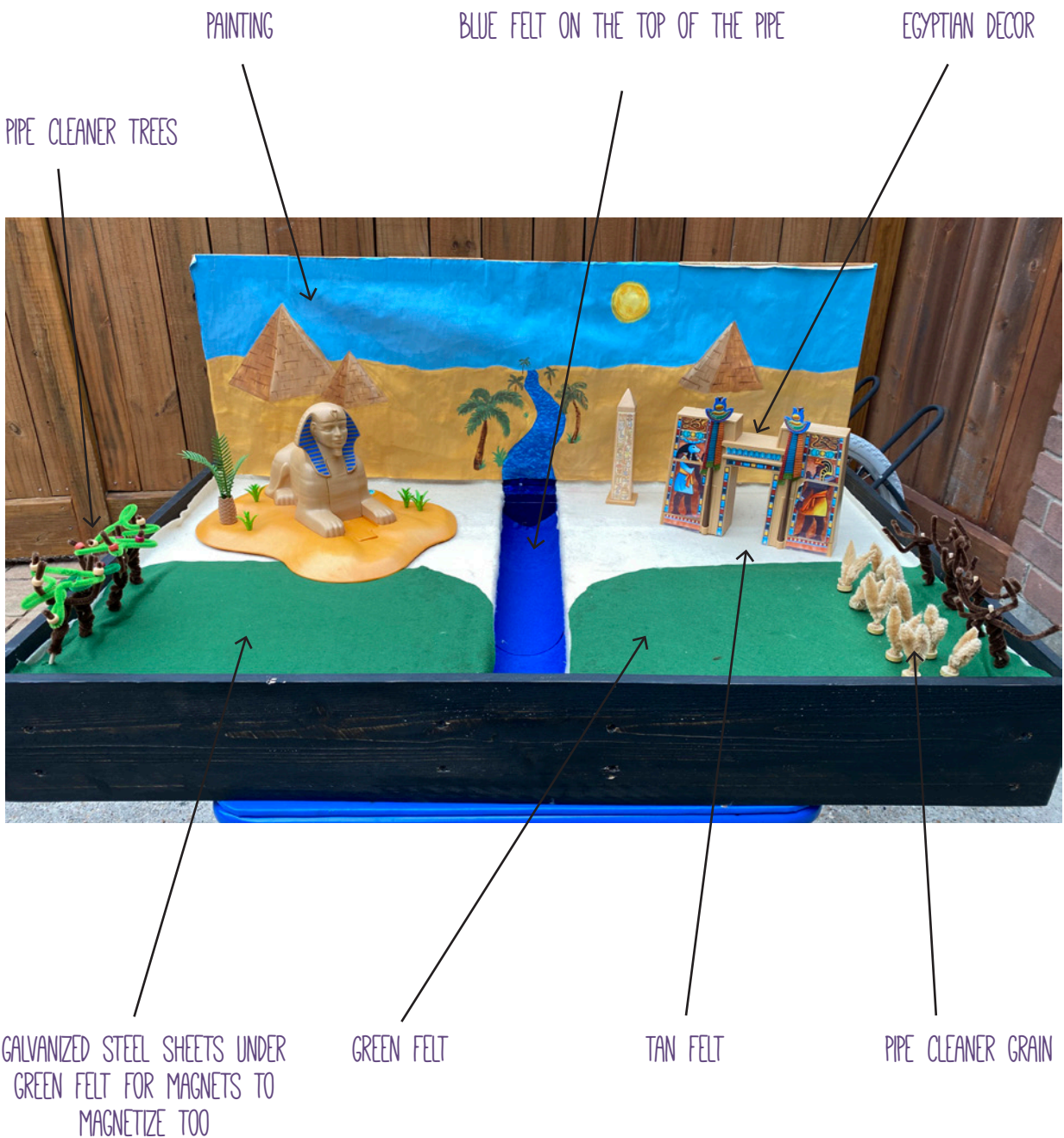

# COWS

PRINT

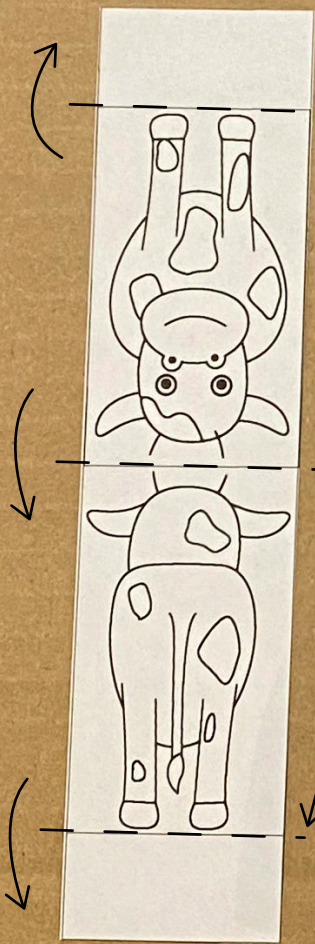

FOLD

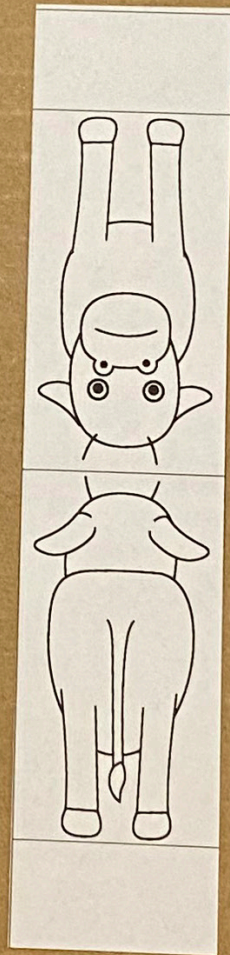
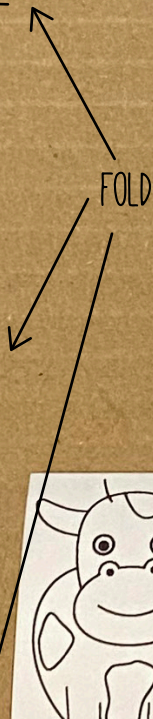

GLUE THE ENDS TOGETHER

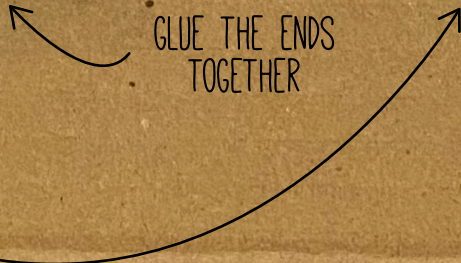

REPEAT THE SAME STEPS FOR THE SKINNY COW

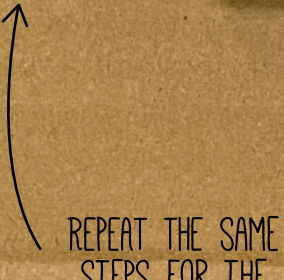

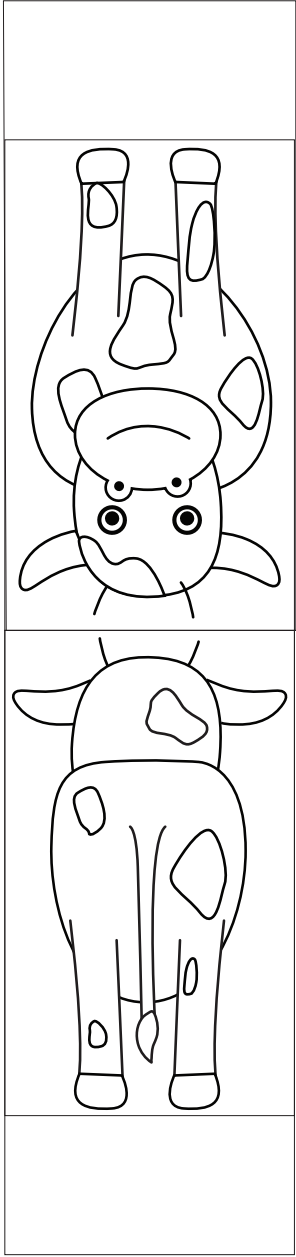
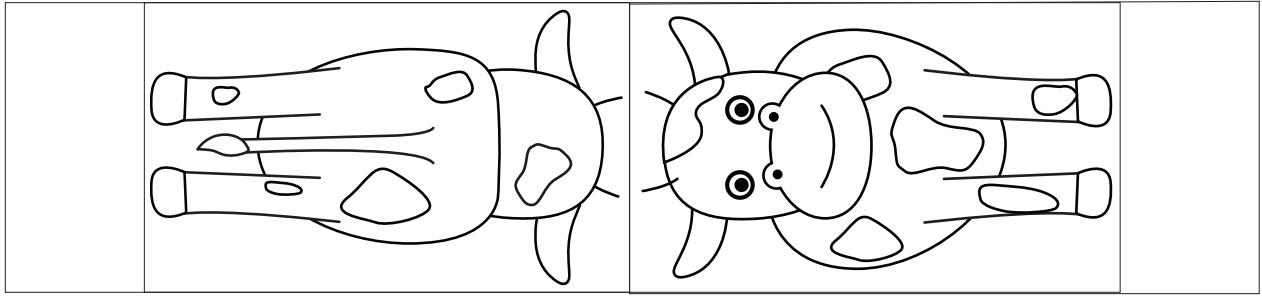
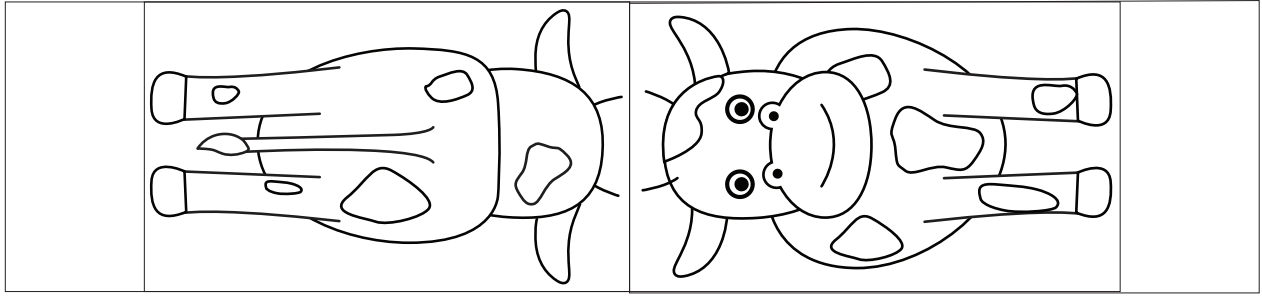
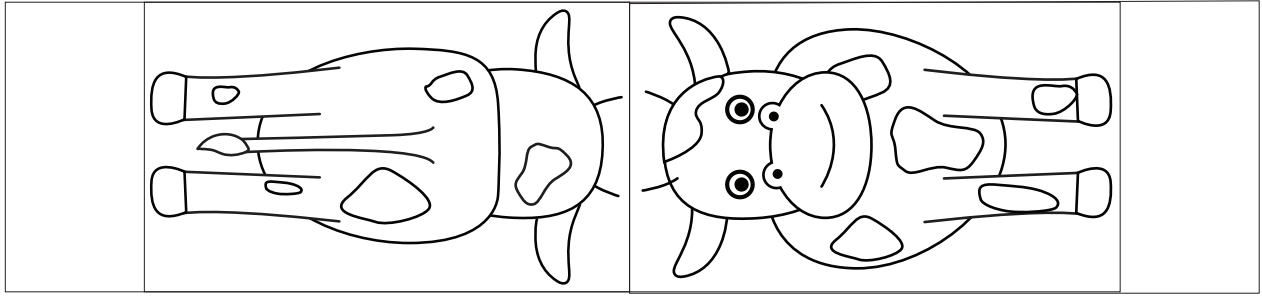
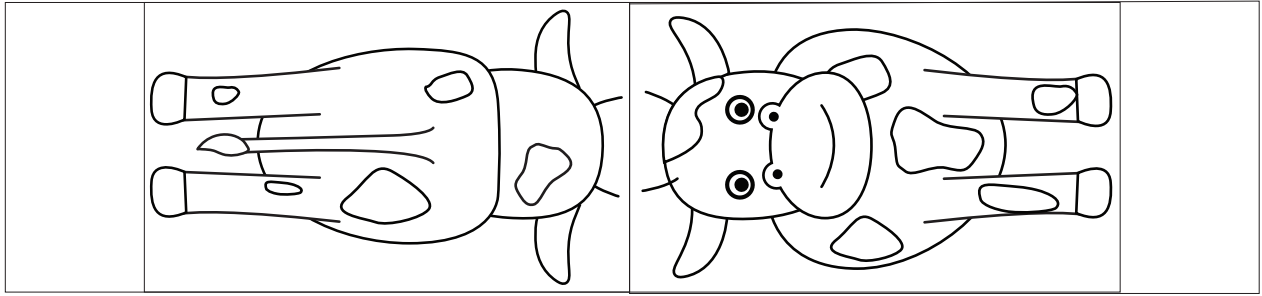
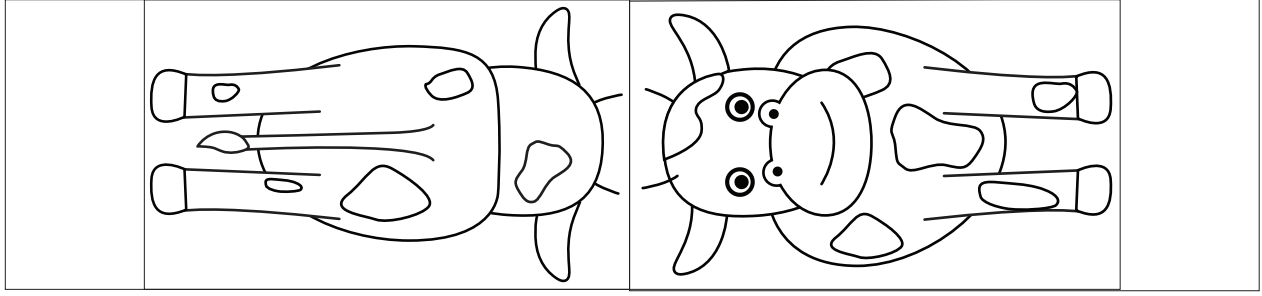
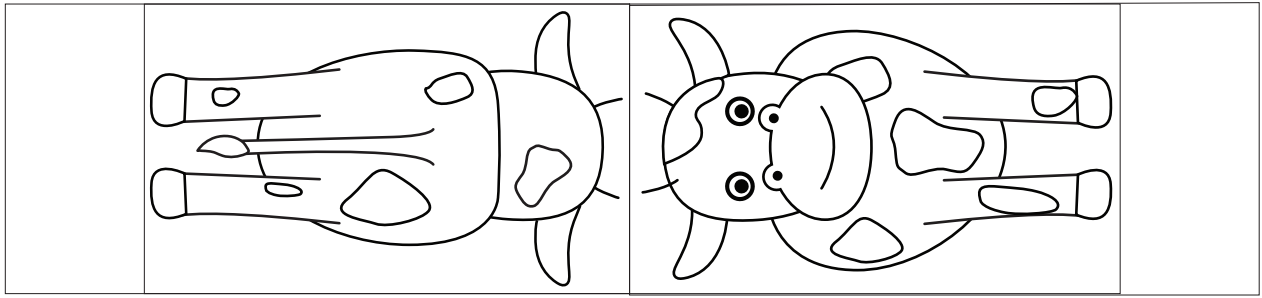

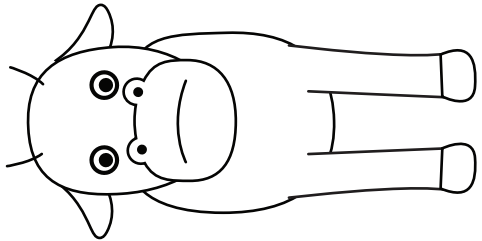
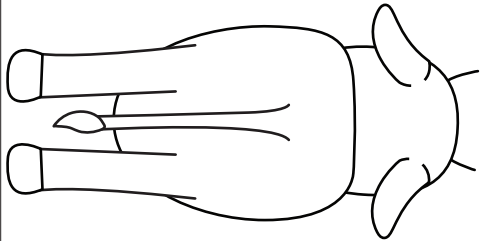
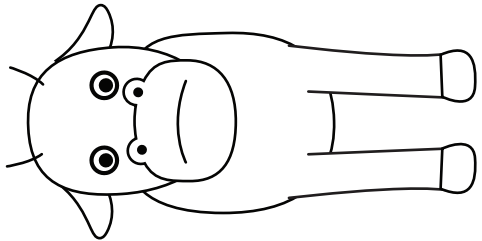
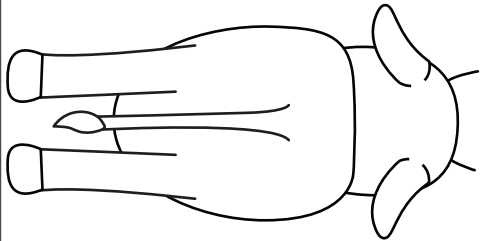
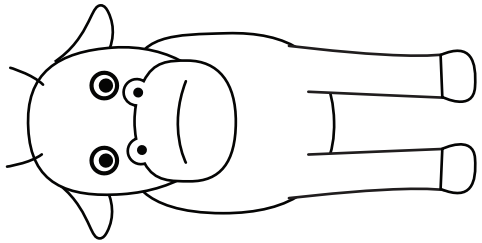
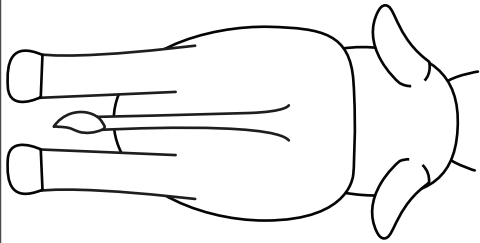
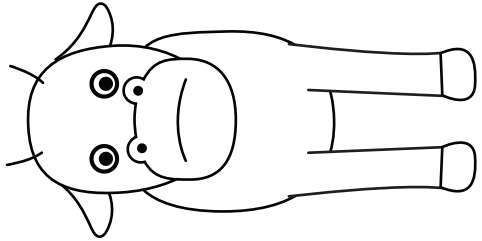
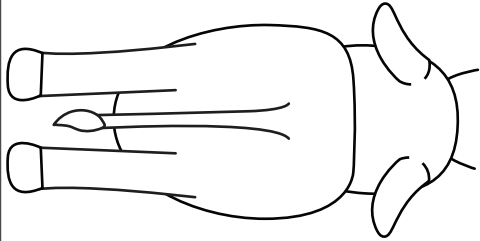
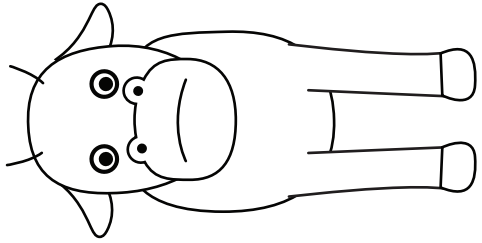
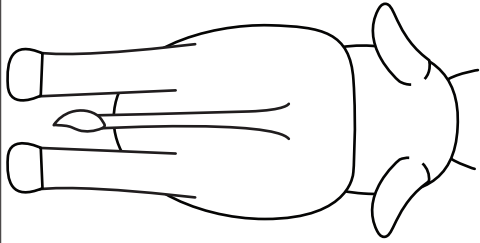
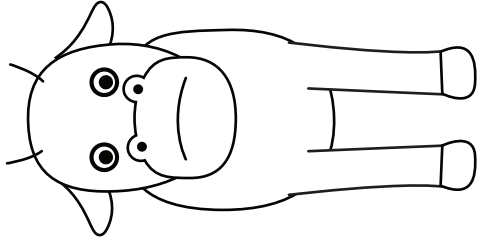
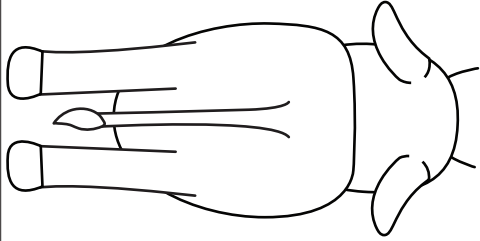
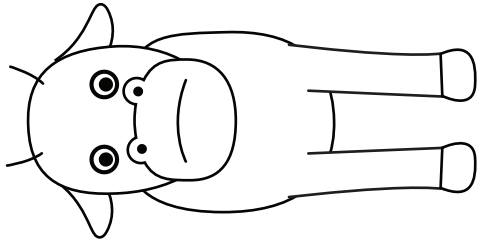
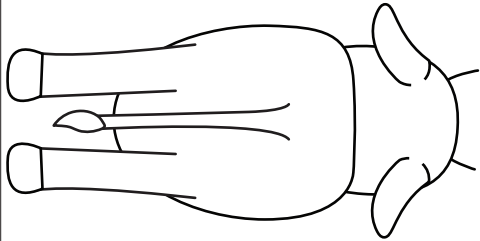

# GRAIN

4 LIGHT BROWN MIX  
WAVE PIPE CLEANERS

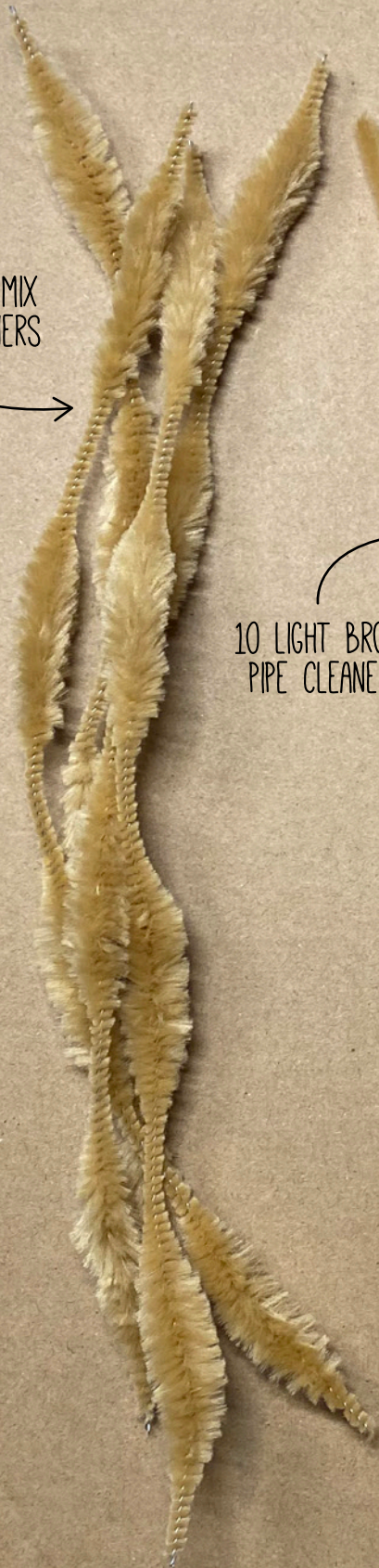
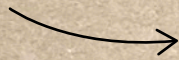

10 LIGHT BROWN  
PIPE CLEANERS

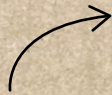

1/8"X12"  
WOODEN DOWEL



.375 NEODYMIUM  
RING MAGNET



5/8"X5/8"  
WOOD BLOCK



2"X2" CIRCLE  
WOOD SHAPE



# GRAIN

WRAP 6 OF THE  
LIGHT BROWN  
PIPE CLEANERS  
AROUND THE  
DOWEL

TUCK AROUND  
THE DOWEL &  
WRAP

CUT THE WAVY &  
REGULAR PIPE CLEANERS  
IN HALF, SO THERE  
ARE 7 OF EACH



# GRAIN

WRAP THE 7 MIX WAVY PIPE CLEANERS AROUND THE DOWEL (THIS REPRESENTS THE 7 GOOD HEADS)

WRAP THE 7 PIPE CLEANERS AROUND THE DOWEL (THIS REPRESENTS THE 7 BAD HEADS)

HOT GLUE THE MAGNET TO THE CIRCLE (THIS ALLOWS IT TO STAND & CONNECT TO THE EGYPT MODEL)

HOT GLUE THE DOWEL INTO THE BLOCK

HOT GLUE THE BLOCK ONTO THE OTHER SIDE OF THE CIRCLE

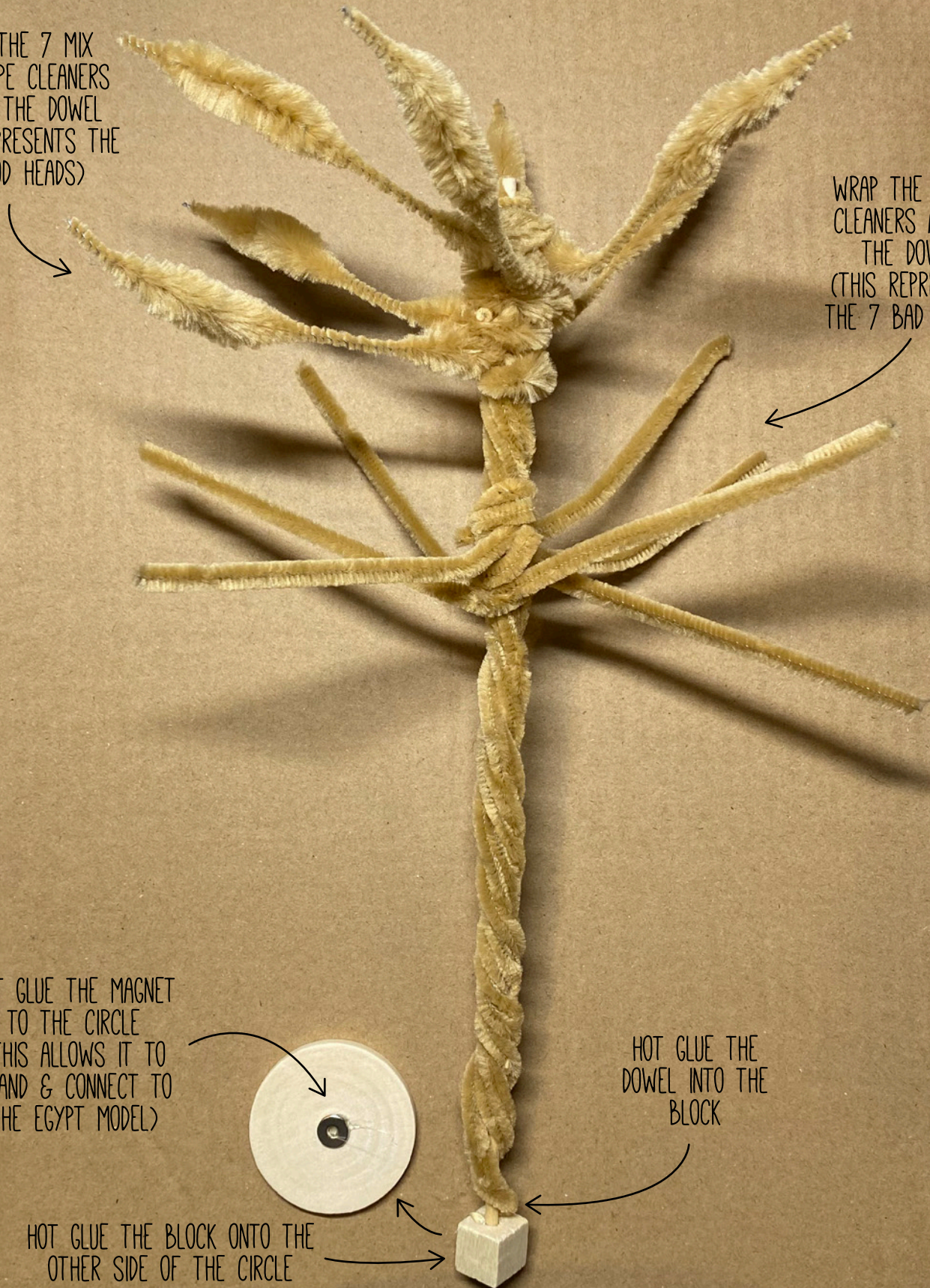

GRAIN

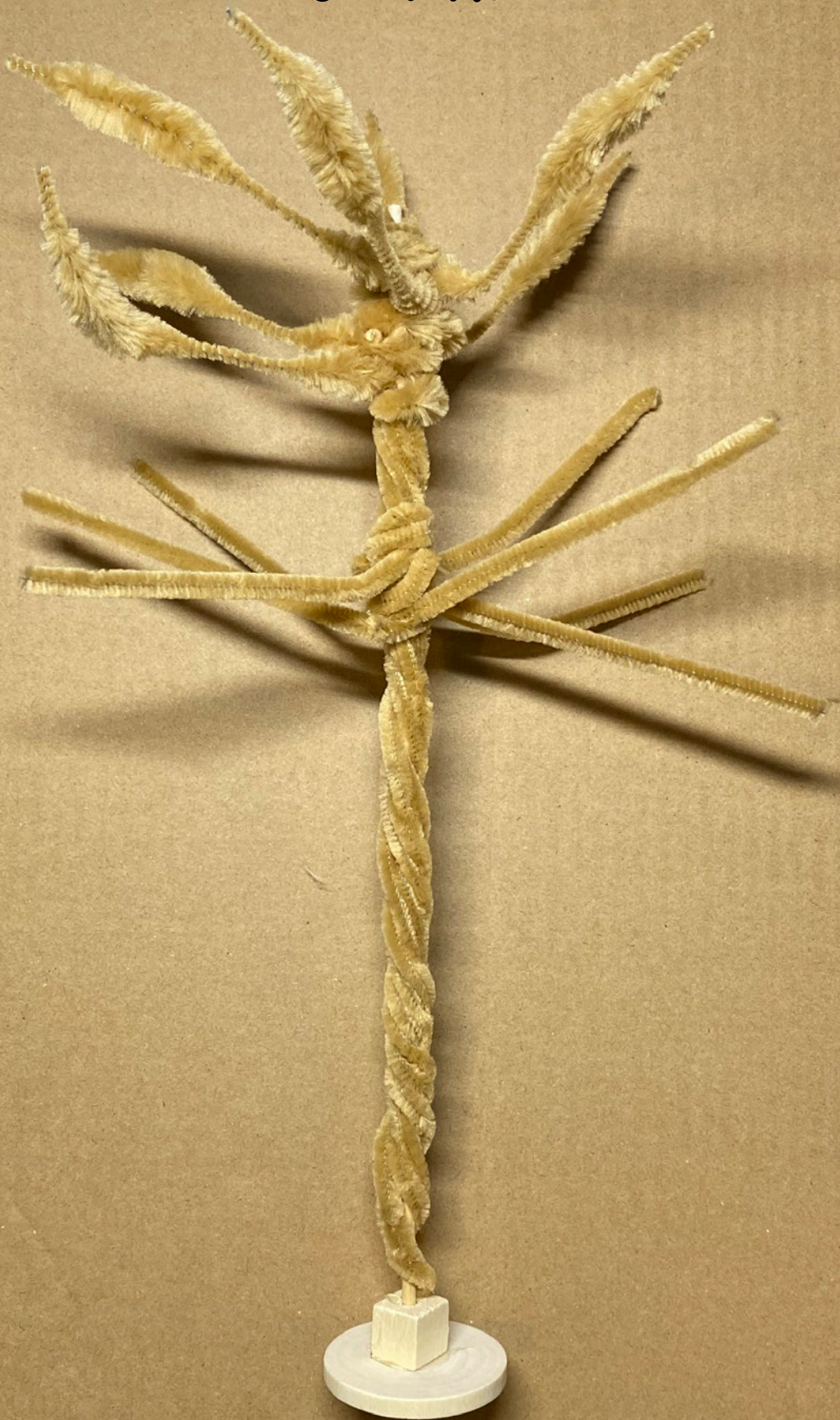



# WHAT DOES THE DREAM MEAN?

DREAM

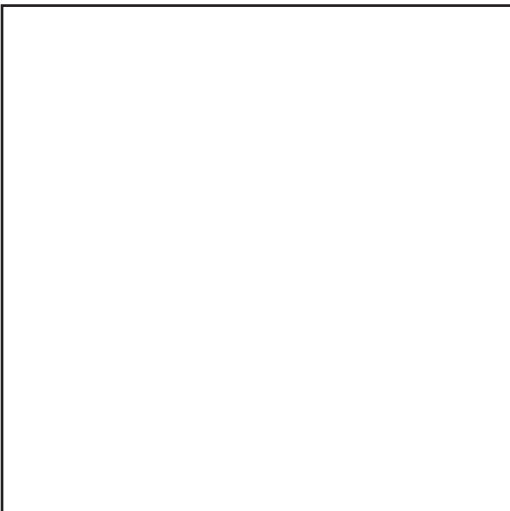
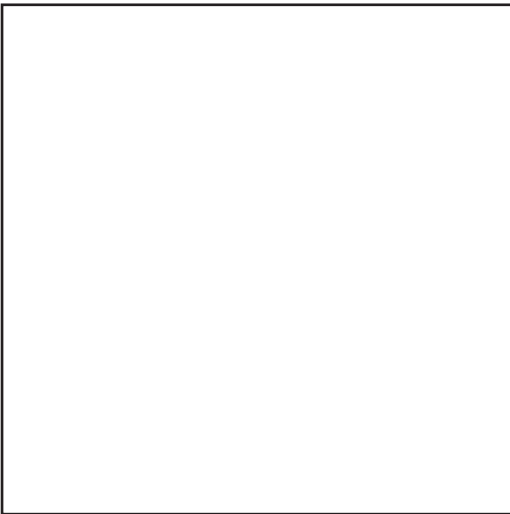
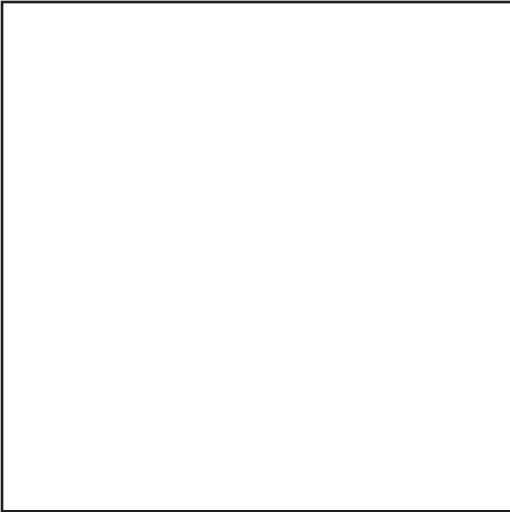

JOSEPH'S INTERPRETATION

---

---

---

---

---

---

# WHAT DOES THE DREAM MEAN?

DREAM

JOSEPH'S INTERPRETATION

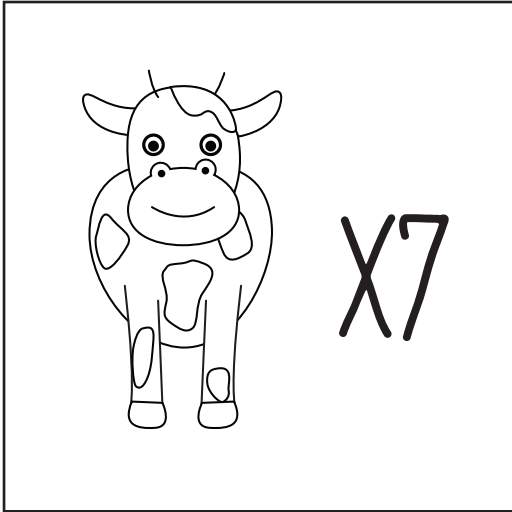

---

---

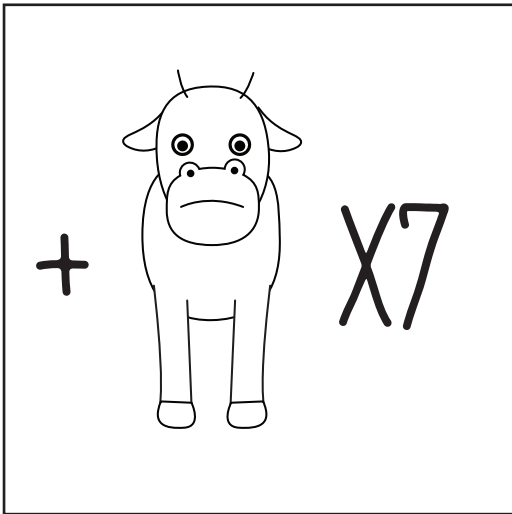

---

---

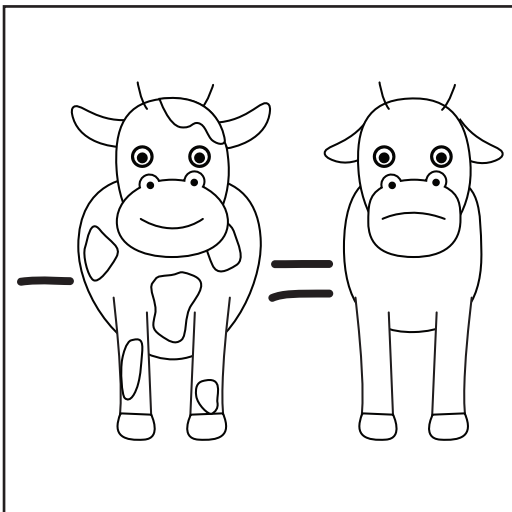

---

---

# WHAT DOES THE DREAM MEAN?

DREAM

JOSEPH'S INTERPRETATION

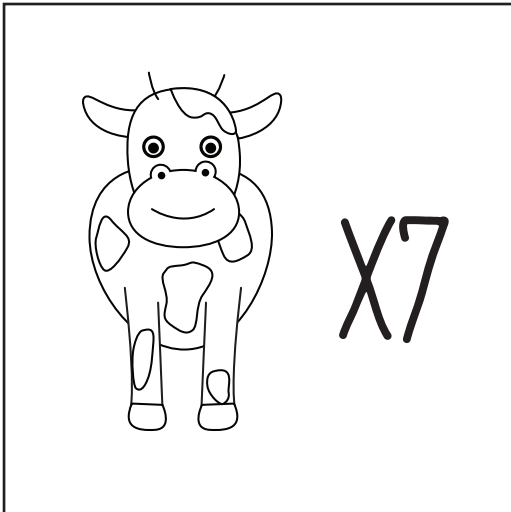

7 YEARS  
PLENTY

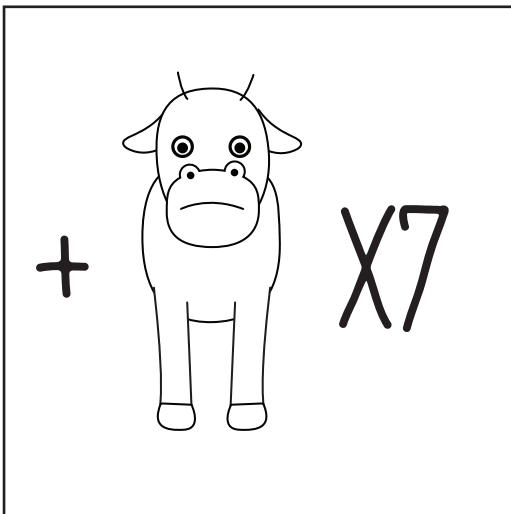

7 YEARS  
FAMINE

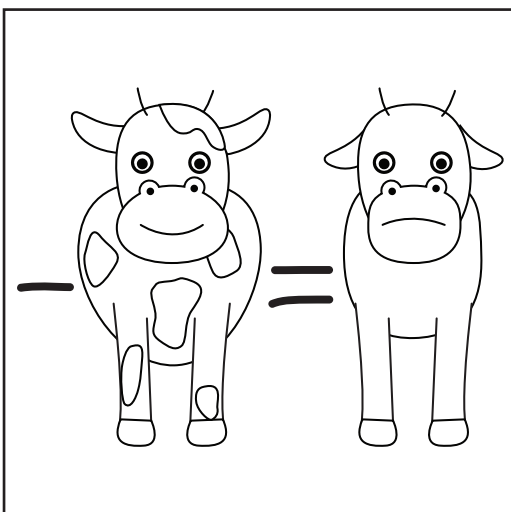

FAMINE BAD,  
NO FOOD LEFT

# WHAT DOES THE DREAM MEAN?

DREAM

JOSEPH'S INTERPRETATION

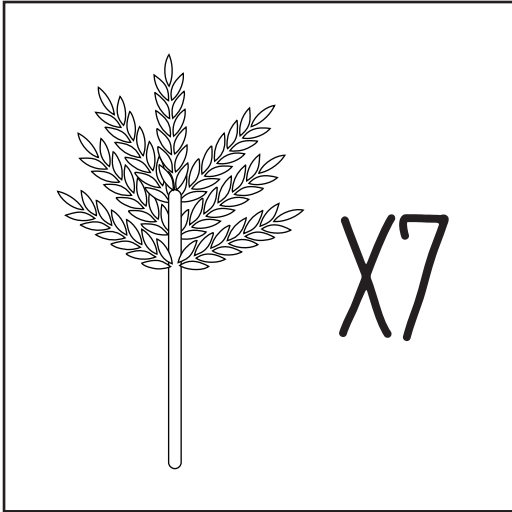

---

---

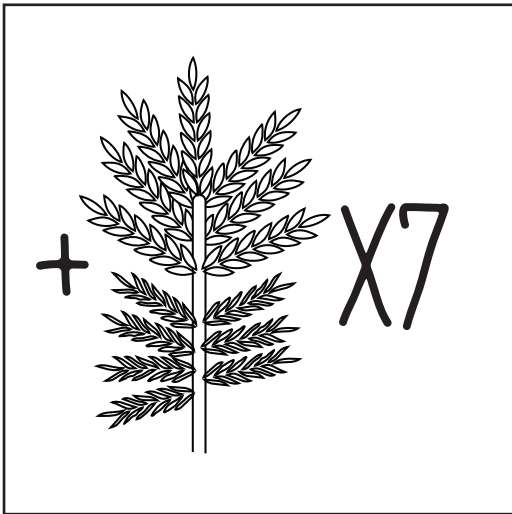

---

---

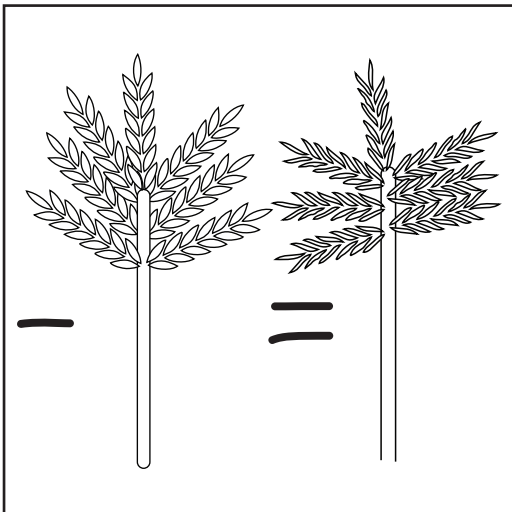

---

---

# WHAT DOES THE DREAM MEAN?

DREAM

JOSEPH'S INTERPRETATION

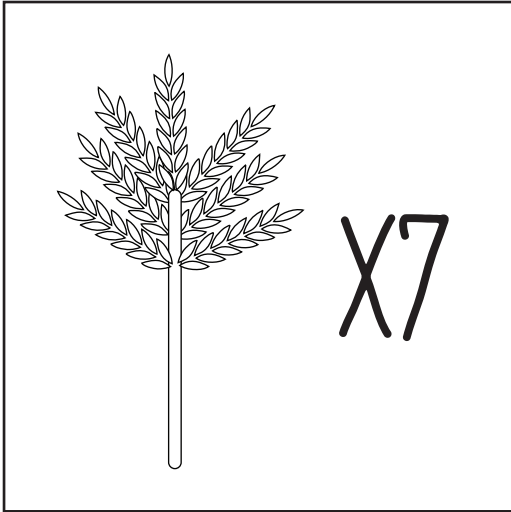

7 YEARS

---

PLENTY

---

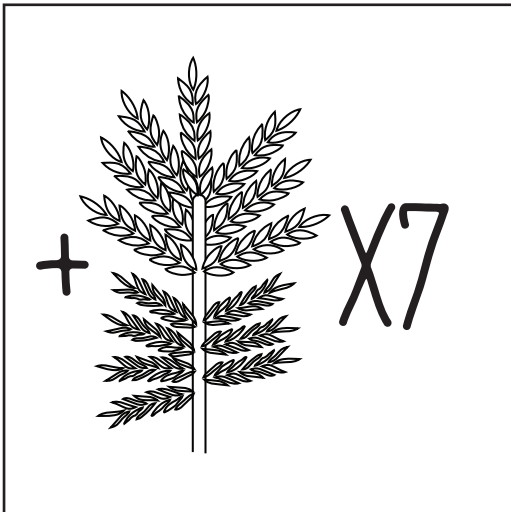

7 YEARS

---

FAMINE

---

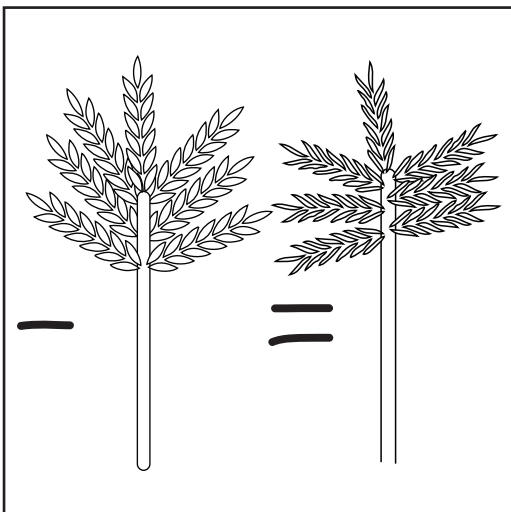

FAMINE BAD,

---

NO FOOD LEFT

---

# JOSEPH'S PLAN

I drew 14 lines on the driveway and numbered each one. Each line represented a year, and the children walked to each one, starting at number 1. They received 1 cracker in their cup from years 1-7 and gave me 1 cracker from years 8-14.

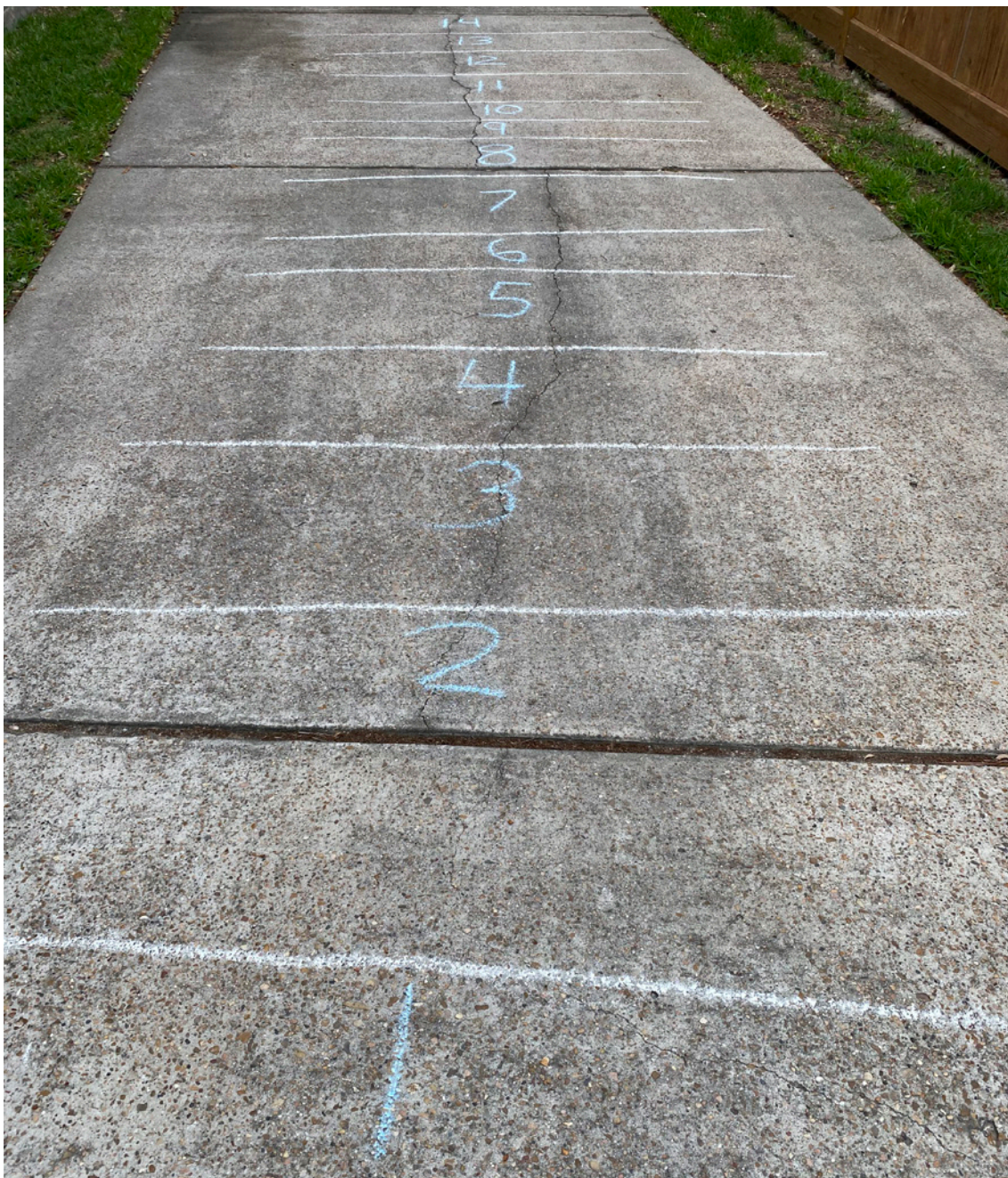

THEN PHARAOH SAID  
TO JOSEPH,  
"IN MY DREAM..."

GENESIS 41:17

THEN PHARAOH SAID  
TO JOSEPH,  
"IN MY DREAM..."

GENESIS 41:17

THEN PHARAOH SAID  
TO JOSEPH,  
"IN MY DREAM..."

GENESIS 41:17

THEN PHARAOH SAID  
TO JOSEPH,  
"IN MY DREAM..."

GENESIS 41:17