



CLOUDS WEEK 2



CLOUDS

CLOUDS

COMING

FOCUS

EXODUS 19:9, 19:16, 19:20 & 40:34, 1 KINGS 8:10,
PSALM 97:2 104:3, EZEKIEL 1:4-5, DANIEL 7:13,
MATTHEW 24:30 & 26:64, 1 THESSALONIANS 4:17
& REVELATION 1:7 & 19:11

God's throne moves on the clouds!
Jesus will come back riding his horse
on the clouds too!

MATERIALS

Coming picture
God's Throne coloring page and cotton balls (1 set per child)
Small wooden chair and small paper plate (1 set per child)
Flashlight
Shofar
Mountain display
Tabernacle coloring page (1 per child)
3D Temple coloring page and ark (1 set per child)
Jesus puppet coloring page and scepter (1 1/2" purple pipe cleaner) (1 set per child)
High Priest, Sanhedrin, person puppets (1 set per child)
Crayons, markers, tape, glue sticks and liquid glue

ACTIVITIES

1. INTRODUCTION

TALK: Ask the children if they know about God and Jesus traveling on the clouds!

ACTIVITY: Show children the Coming picture and hang nearby for them to see.



2. THRONE

TALK: In heaven, God's throne is surrounded by clouds and thick darkness!

ACTIVITY: Have children color the God's Throne coloring page and glue cotton balls around it.

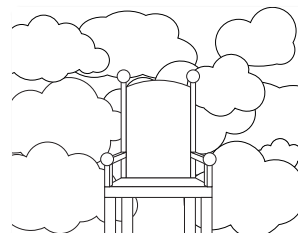

CORRESPONDING VERSE

CLOUDS AND THICK DARKNESS SURROUND HIM; RIGHTEOUSNESS AND JUSTICE ARE THE FOUNDATION OF HIS THRONE.

PSALM 97:2

ACTIVITIES

3. CHARIOT

TALK: God can make clouds his chariot and ride on the wings of the wind!

ACTIVITY: Give each child a chair to color and tape it to the center of a white paper plate.



CORRESPONDING VERSE

AND LAYS THE BEAMS OF HIS UPPER CHAMBERS ON THEIR WATERS. HE MAKES THE CLOUDS HIS CHARIOT AND RIDES ON THE WINGS OF THE WIND.

PSALM 104:3

4. EZEKIEL'S VISION

TALK: Ezekiel had a vision of God coming towards him in a cloud! The cloud had fire flashing back and forth and a bright light all around it!

ACTIVITY: Have the children draw lightning to their cloud diagram and take turns shining a flashlight behind it.

I LOOKED AND SAW A WHIRLWIND COMING FROM THE NORTH, A GREAT CLOUD WITH FIRE FLASHING BACK AND FORTH AND BRILLIANT LIGHT ALL AROUND IT. IN THE CENTER OF THE FIRE WAS A GLEAM LIKE AMBER, AND WITHIN IT WAS THE FORM OF FOUR LIVING CREATURES.

EZEKIEL 1:4-5

ACTIVITIES

8. DANIEL'S VISION

TALK: Daniel had a vision that he saw the Son of Man coming on the clouds of heaven! The book of Revelation says he will be riding a white horse!

ACTIVITY: Have the children color, assemble and tape the Jesus puppet coloring page next to the chair.

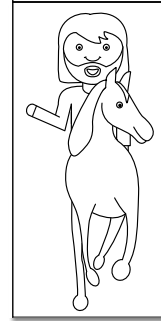

CORRESPONDING VERSE

IN MY VISION IN THE NIGHT I CONTINUED TO WATCH, AND I SAW ONE LIKE THE SON OF MAN COMING WITH THE CLOUDS OF HEAVEN.

DANIEL 7:13

NOW I SAW HEAVEN OPENED, AND BEHOLD, A WHITE HORSE. AND HE WHO SAT ON HIM WAS CALLED FAITHFUL AND TRUE

REVELATION 19:11

9. POWER & GLORY

TALK: Jesus told his disciples that the Son of Man will come back on the clouds with power and great glory!

ACTIVITY: Have the children tape a scepter to Jesus.

THEY WILL SEE THE SON OF MAN COMING ON THE CLOUDS OF HEAVEN WITH POWER AND GREAT GLORY.

MATTHEW 24:30

10. JESUS COMING

TALK: When Jesus was before the high priest and Sanhedrin he told them that they would see the Son of Man sitting next to God and coming on the clouds of heaven!

ACTIVITY: Have the children color and assemble the high priest and Sanhedrin puppet and place it in front of the cloud diagram.

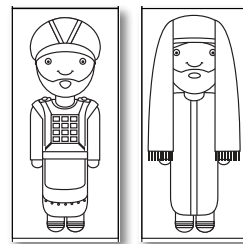

"YOU HAVE SAID IT YOURSELF," JESUS ANSWERED. "BUT I SAY TO ALL OF YOU, FROM NOW ON YOU WILL SEE THE SON OF MAN SITTING AT THE RIGHT HAND OF POWER AND COMING ON THE CLOUDS OF HEAVEN."

MATTHEW 26:64

11. WE SEE HIM

TALK: In the book of Revelation John said when Jesus comes on the clouds, everyone will see him!

ACTIVITY: Have the children color their own puppet and place it in front of the cloud diagram next to the other puppets.

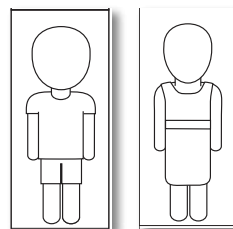

BEHOLD, HE IS COMING WITH THE CLOUDS, AND EVERY EYE WILL SEE HIM—EVEN THOSE WHO PIERCED HIM. AND ALL THE TRIBES OF THE EARTH WILL MOURN BECAUSE OF HIM. SO SHALL IT BE! AMEN.

REVELATION 1:7

ACTIVITIES

12. IN THE CLOUDS TOO

TALK: In the book of Thessalonians Paul wrote that when Jesus comes back on the clouds, those who follow him and are still alive will meet him in the air!

ACTIVITY: Have the children add their puppet to the cloud next to Jesus.

OPTIONAL: Hand out each child a bible verse to take home.

THEY WILL SEE THE SON OF MAN
COMING ON THE CLOUDS OF HEAVEN
WITH POWER AND GREAT GLORY.

MATTHEW 24:30

CORRESPONDING VERSE

AFTER THAT, WE WHO ARE
ALIVE AND REMAIN WILL BE
CAUGHT UP TOGETHER WITH
THEM IN THE CLOUDS TO
MEET THE LORD IN THE AIR.
AND SO WE WILL ALWAYS
BE WITH THE LORD.

1 THESSALONIANS 4:17

COMING

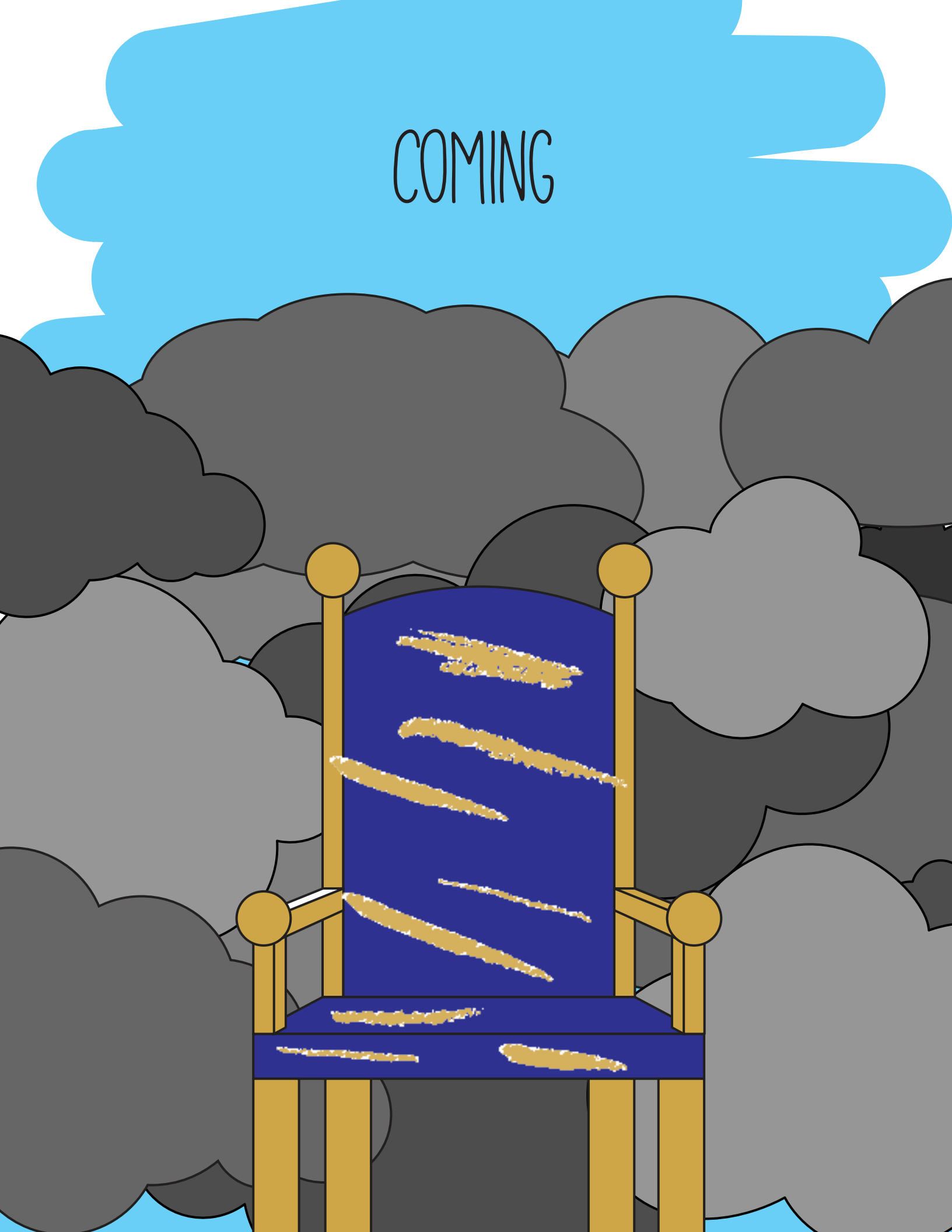

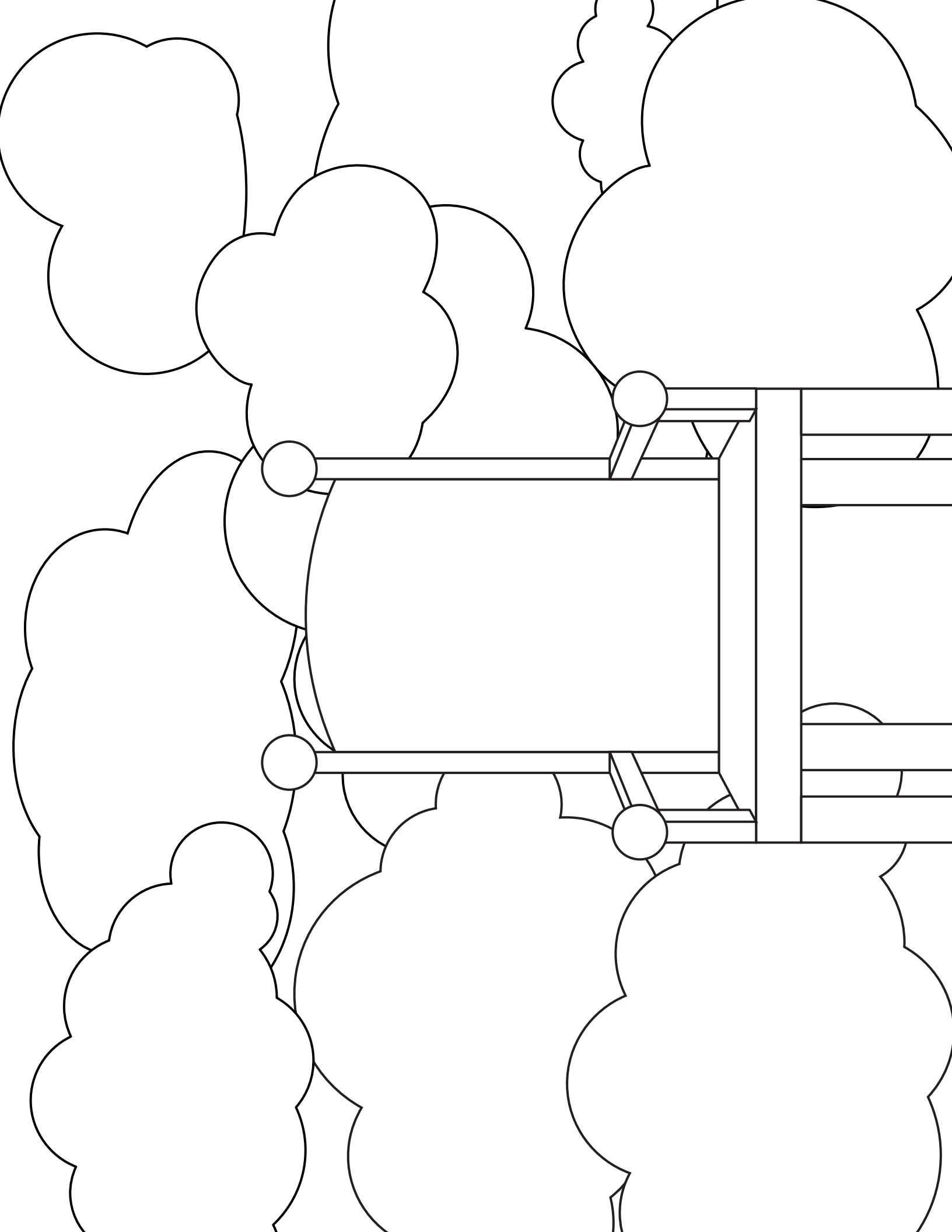

MOUNTAIN

I cut a large piece of cardboard into the shape of a mountain and drew lines on it.





ARK OF THE COVENANT

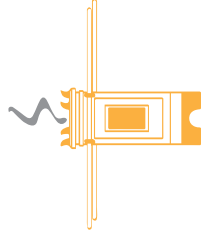

ALTAR OF INCENSE

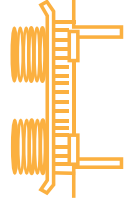

BREAD



MENORAH



BASIN



ALTAR

GATES
OF
PRAISE

TEMPLE

PRINT & CUT OUT
ON THE OUTSIDE LINE

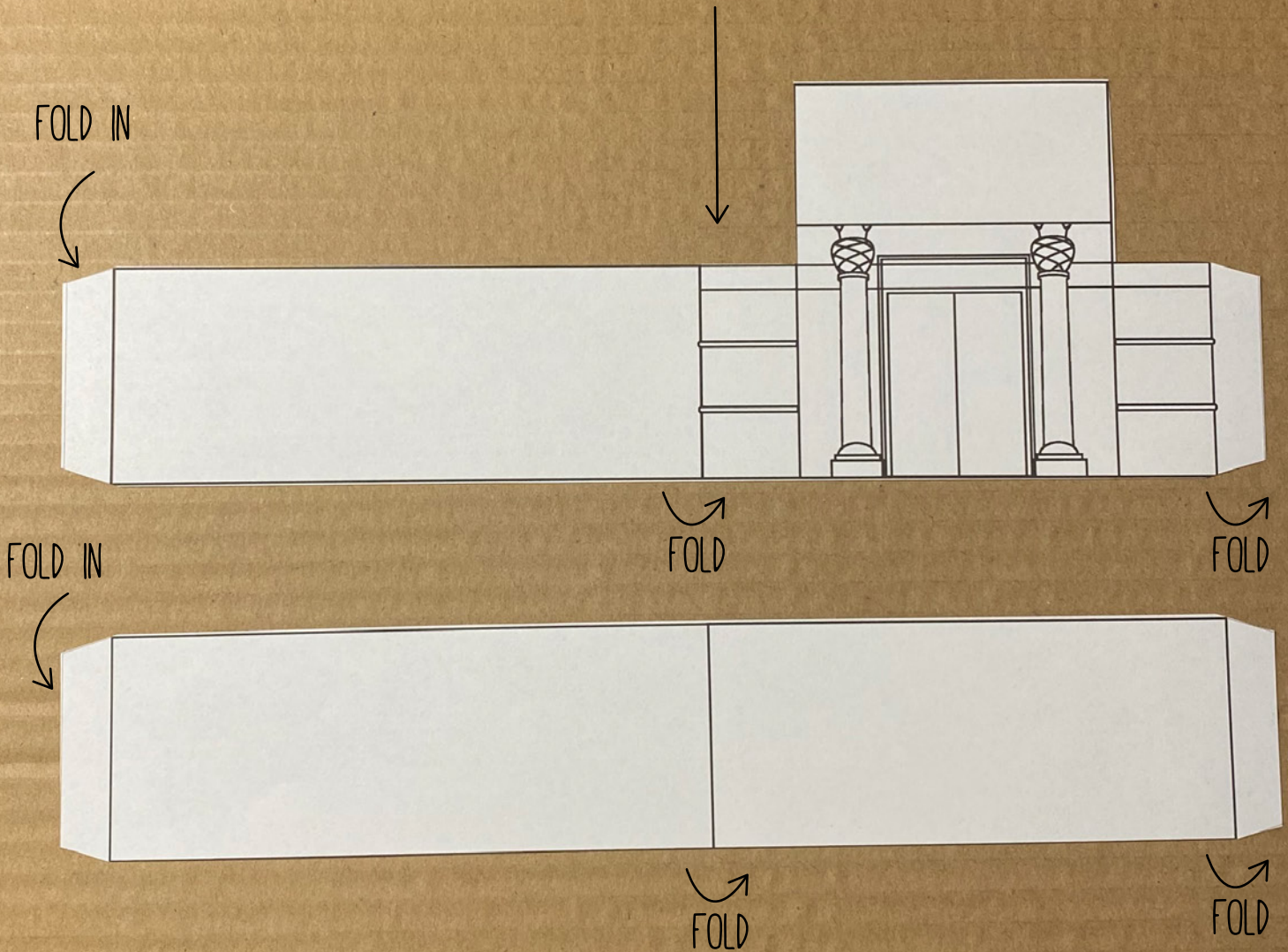

FOLD TO FORM A BOX & GLUE THE FLAPS
ONTO THE EDGES TO FORM A BOX

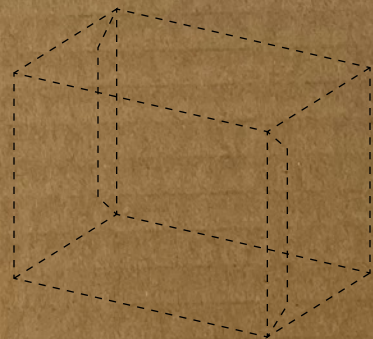

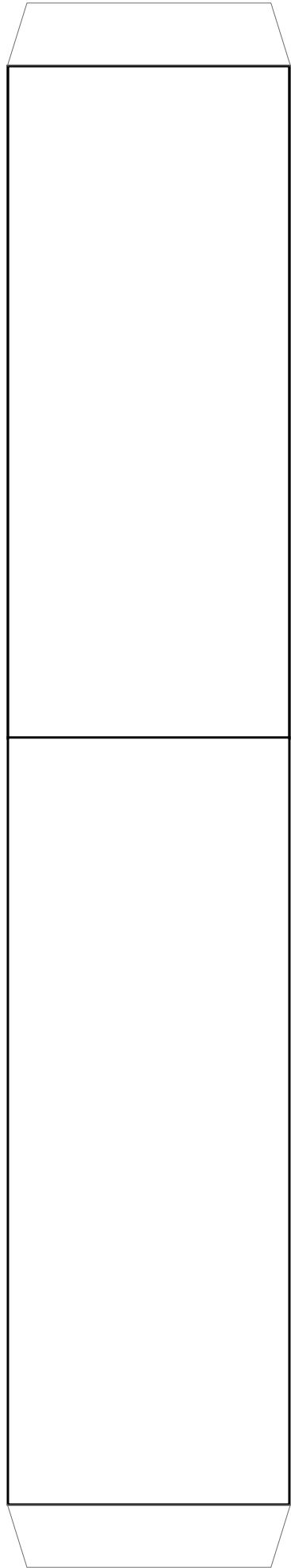
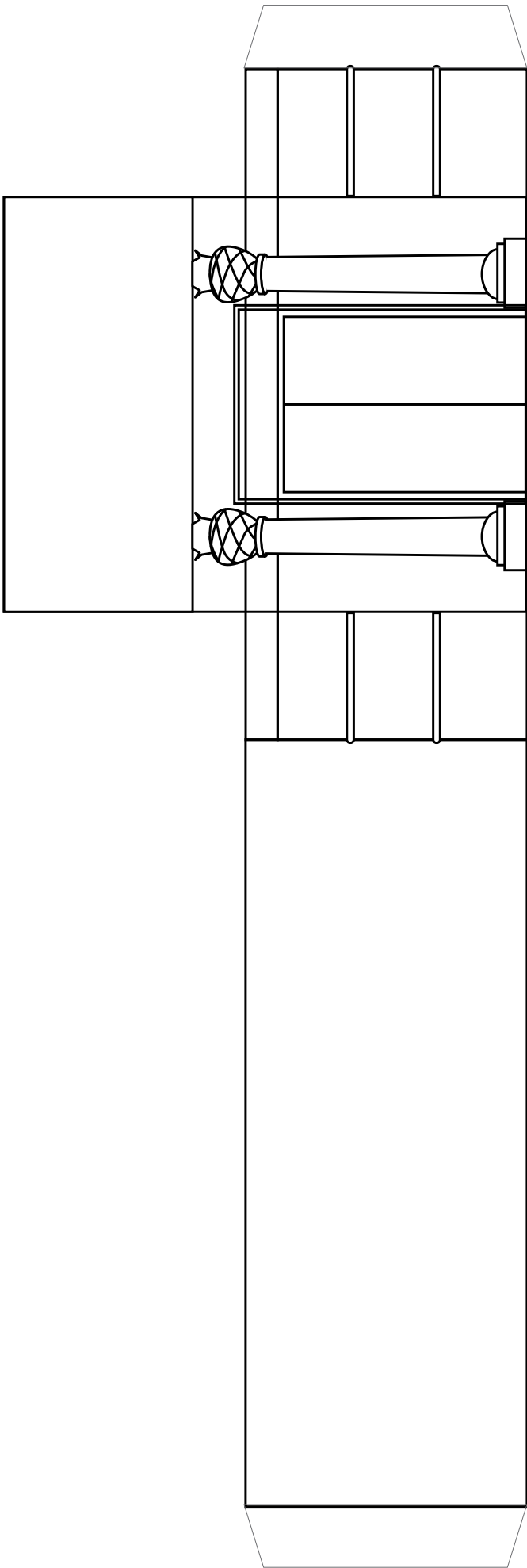

ARK

PRINT ON CARD STOCK & CUT OUT
ON THE OUTSIDE GRAY LINE

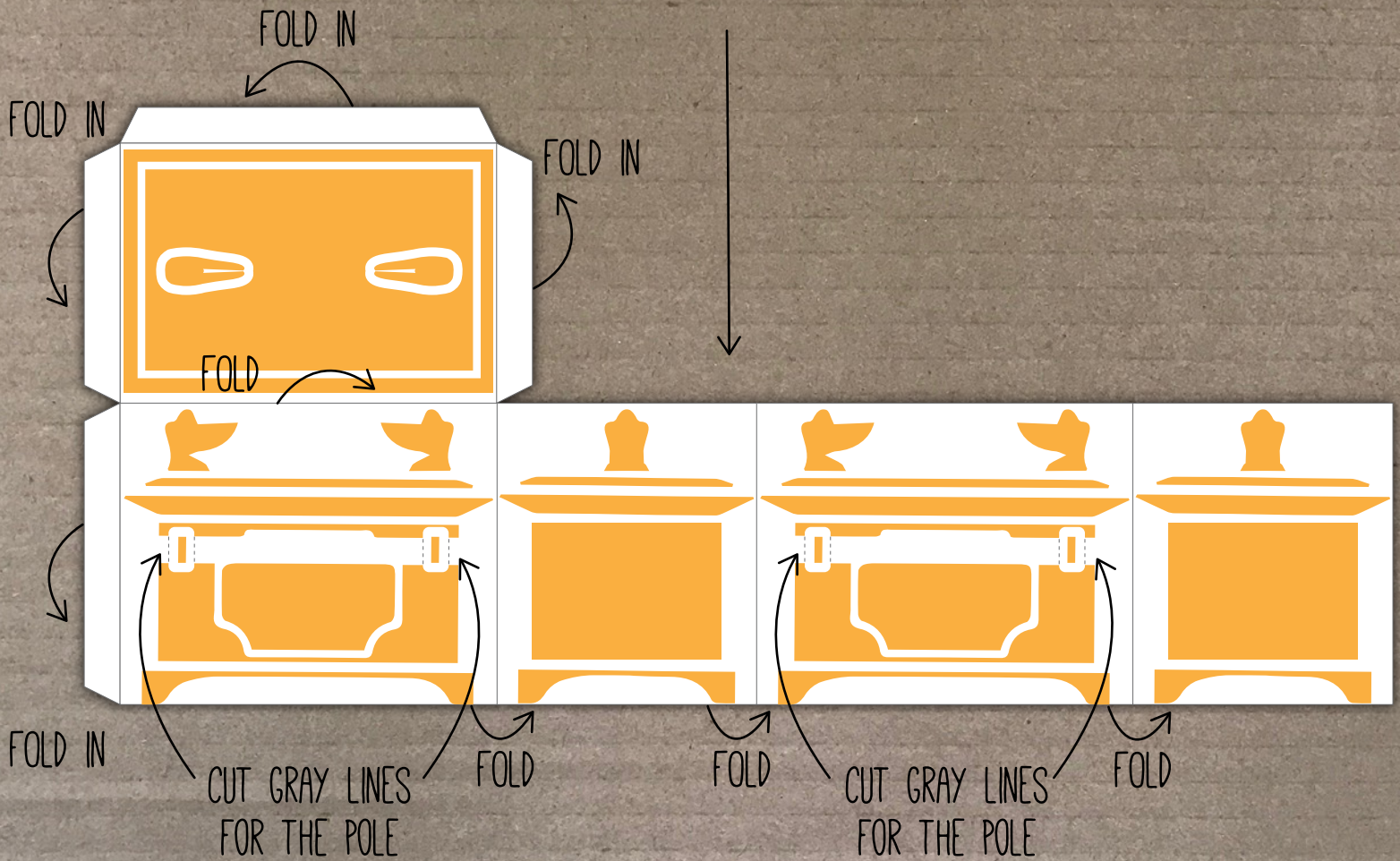

FOLD TO FORM A BOX & GLUE THE FLAPS
ONTO THE EDGES TO FORM A BOX

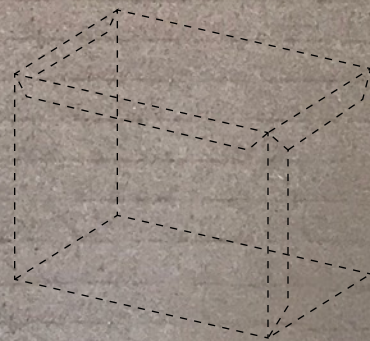

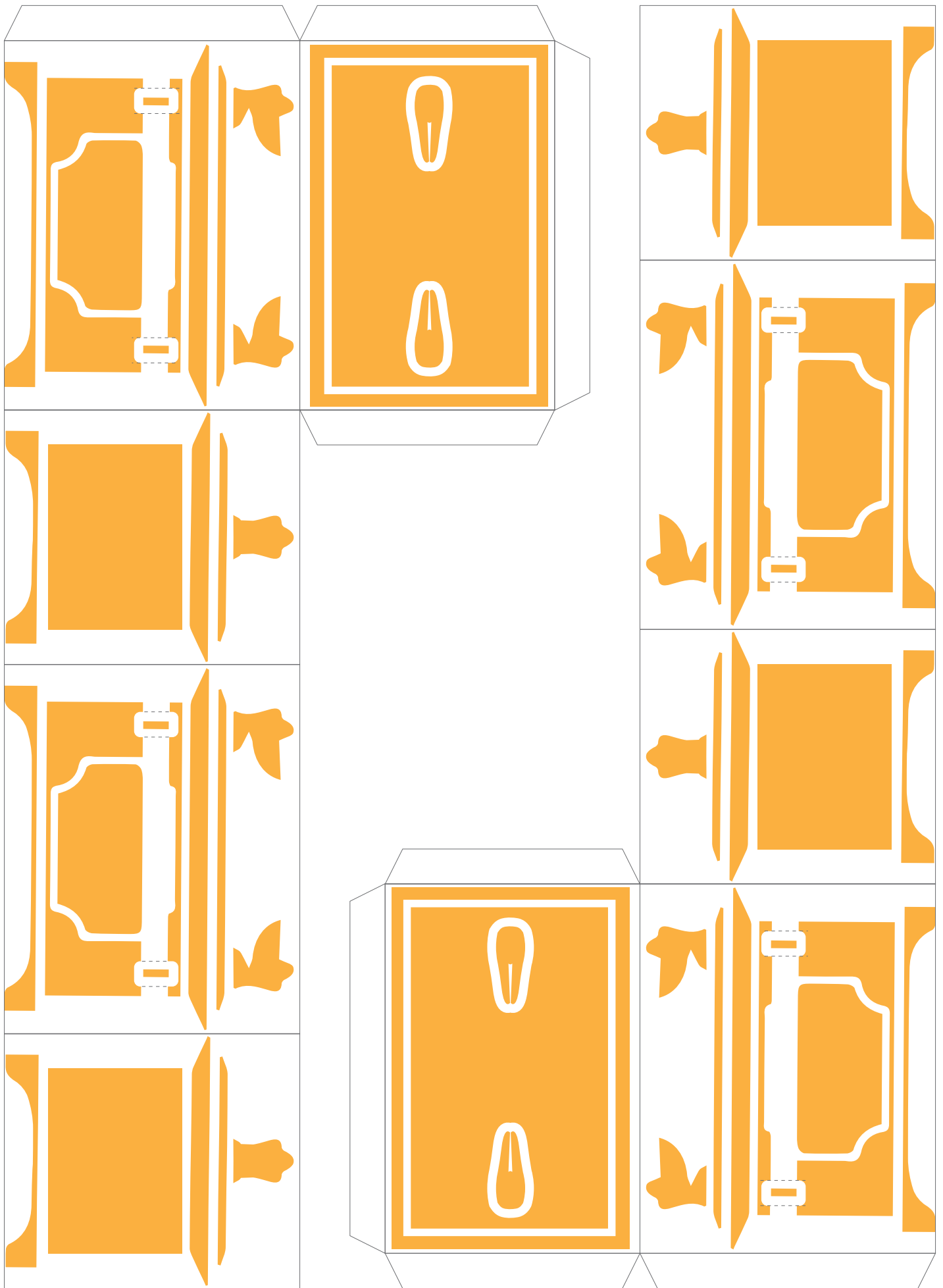

TEMPLE

PLACE THE ARK INSIDE THE TEMPLE

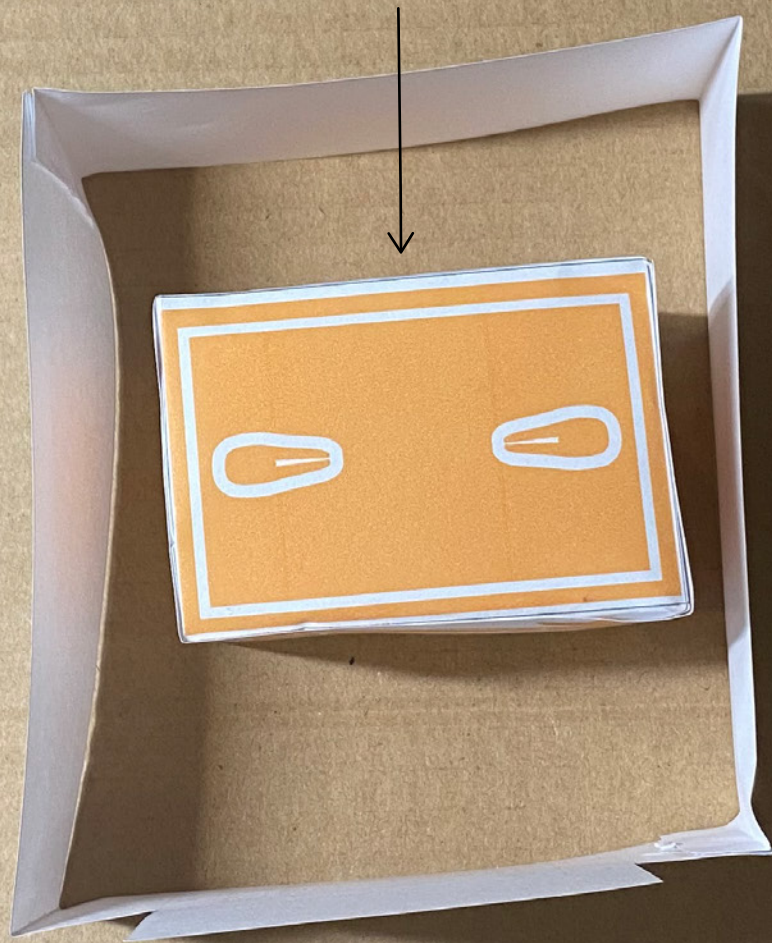

PUPPETS

PRINT, CUT OUT & FOLD

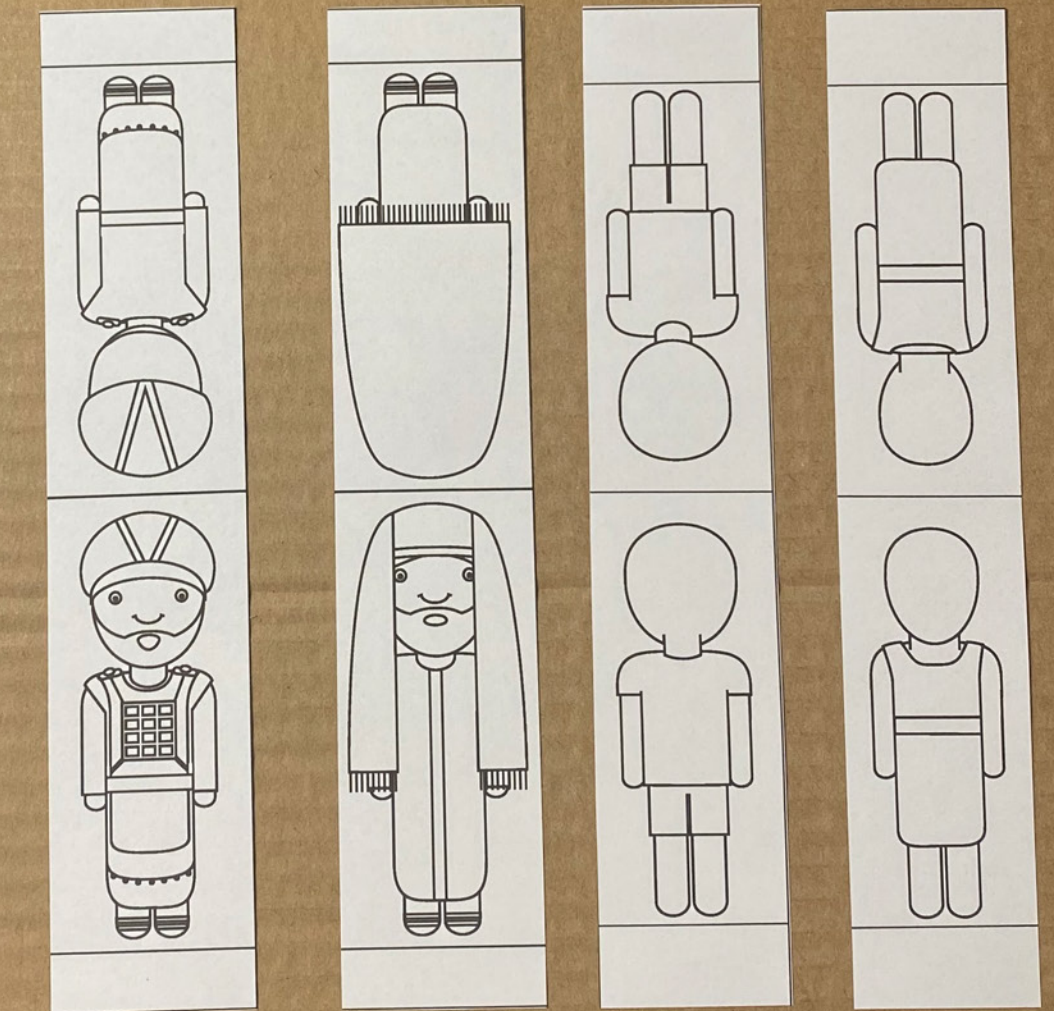

CUT OUT, FOLD & GLUE ENDS TOGETHER



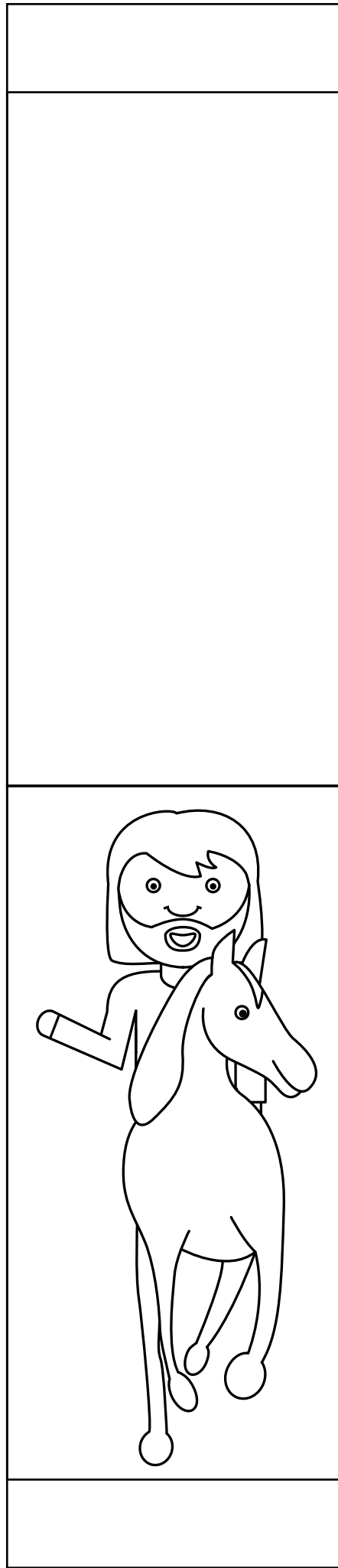
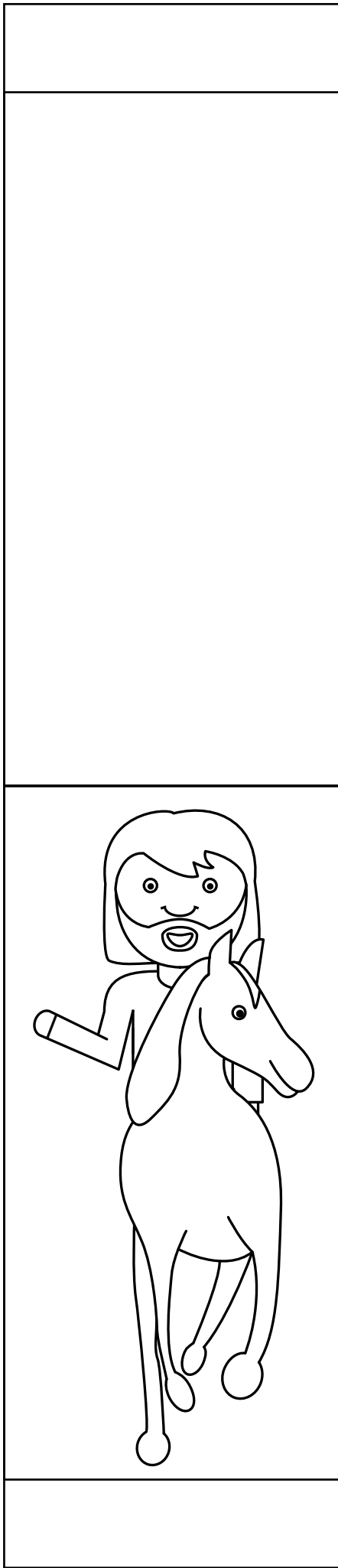
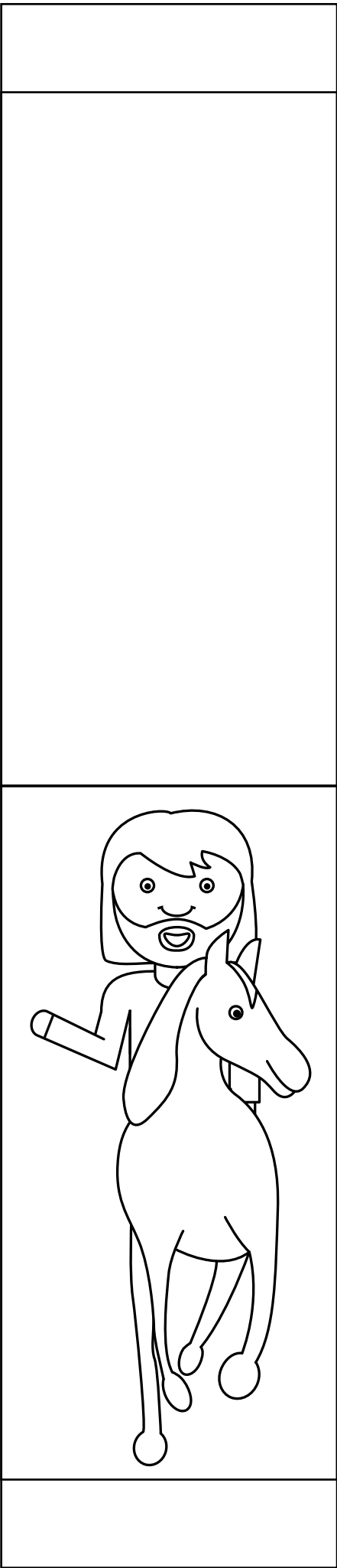

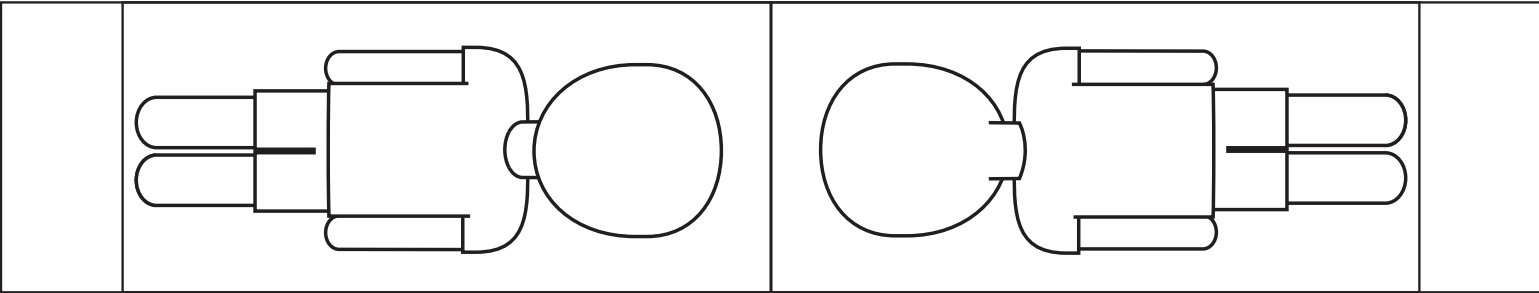
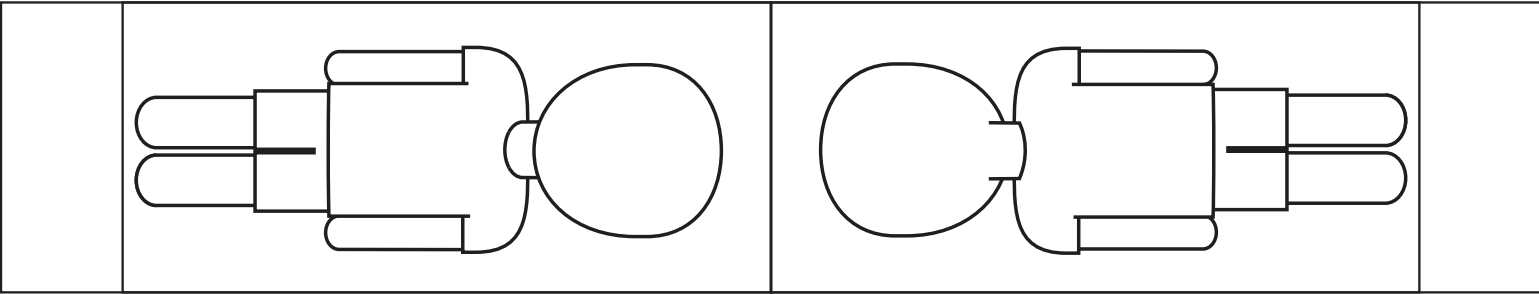
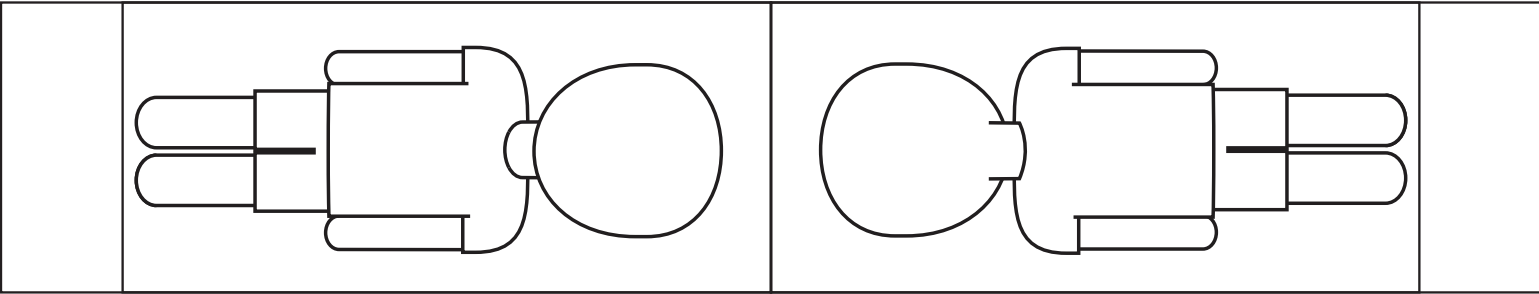
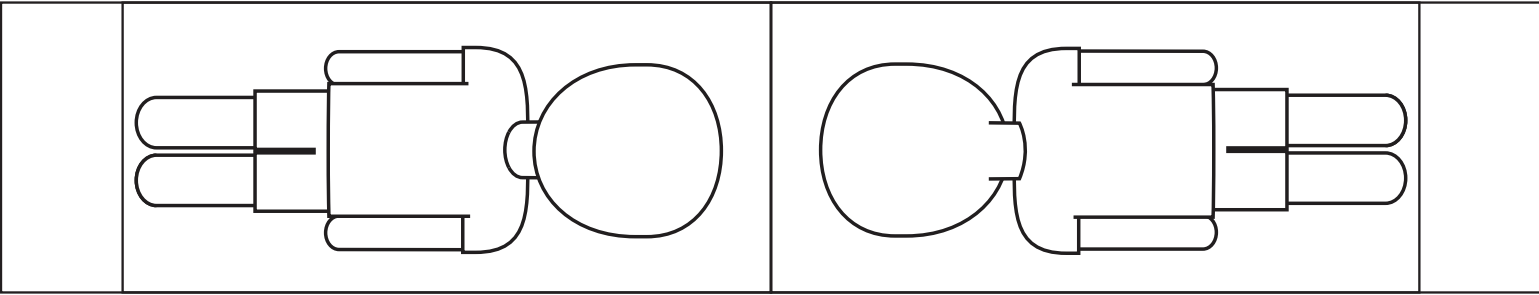
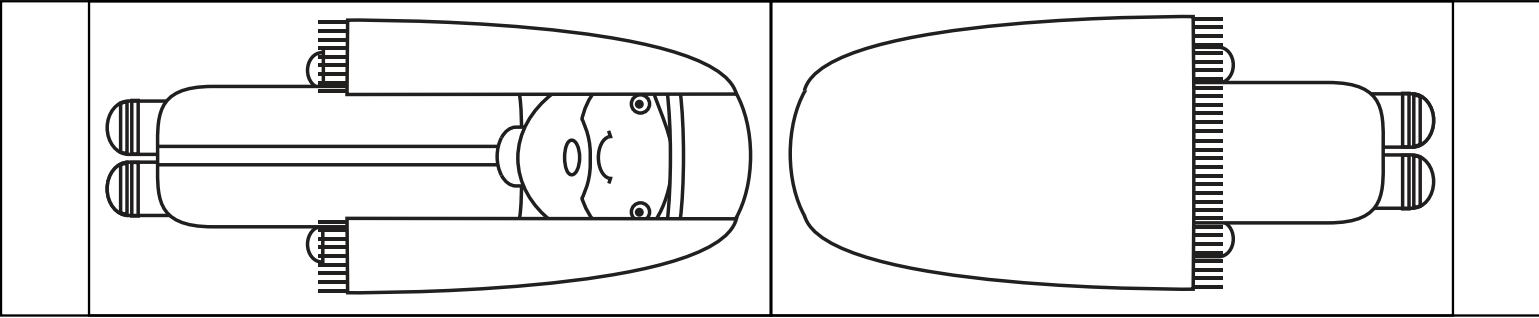
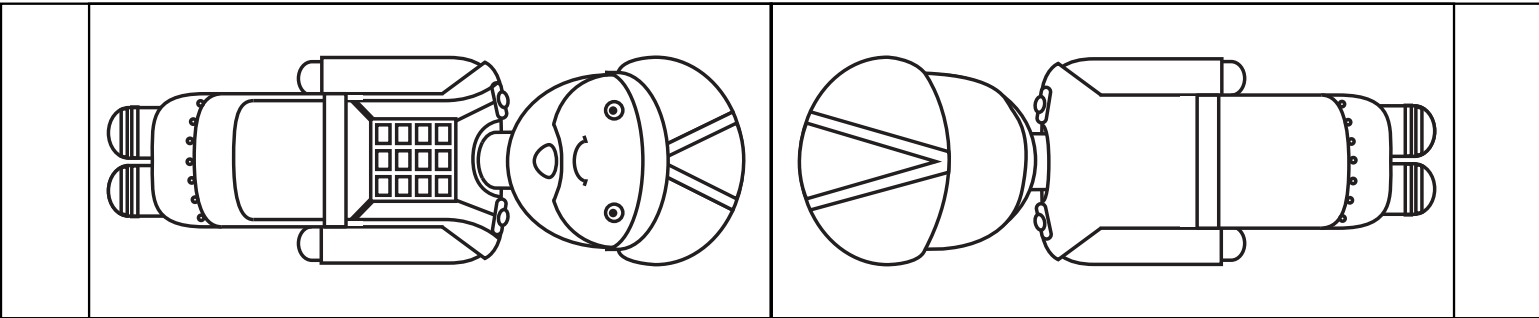

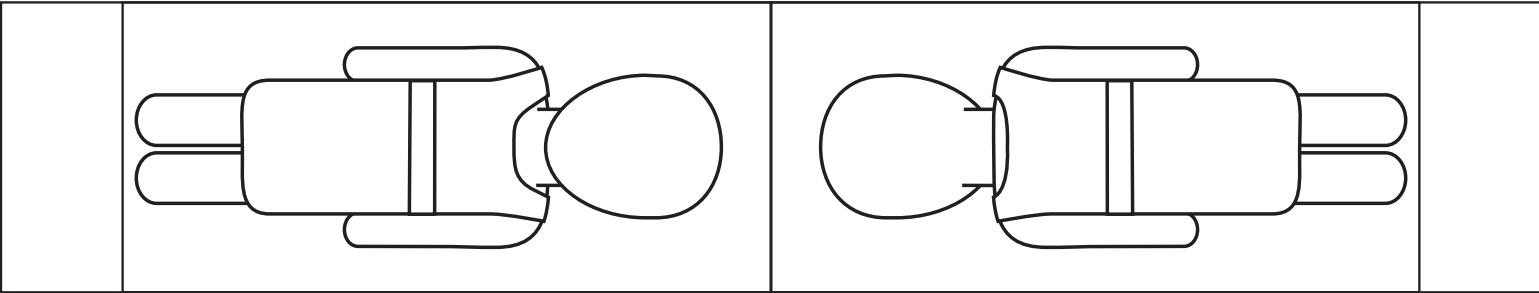
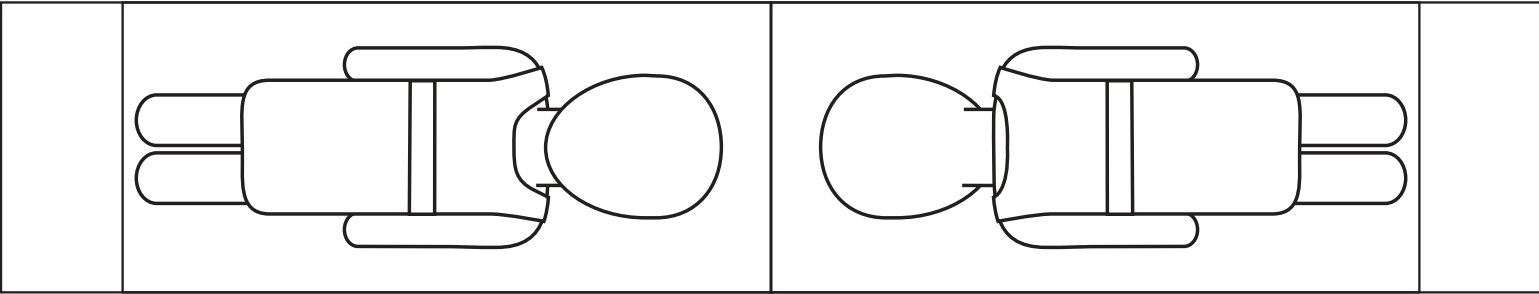
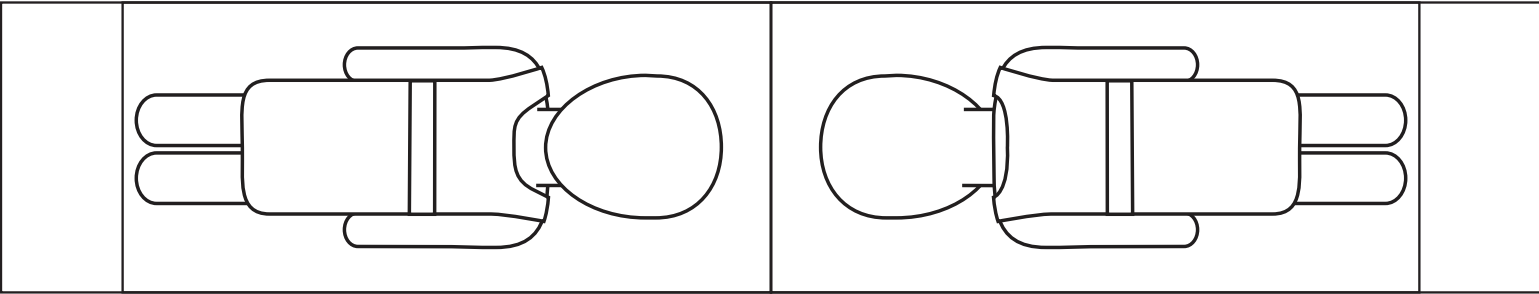
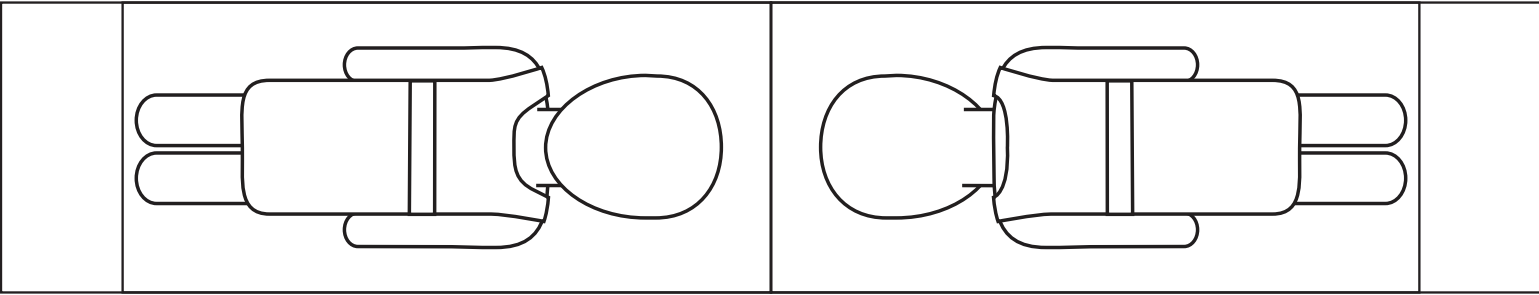
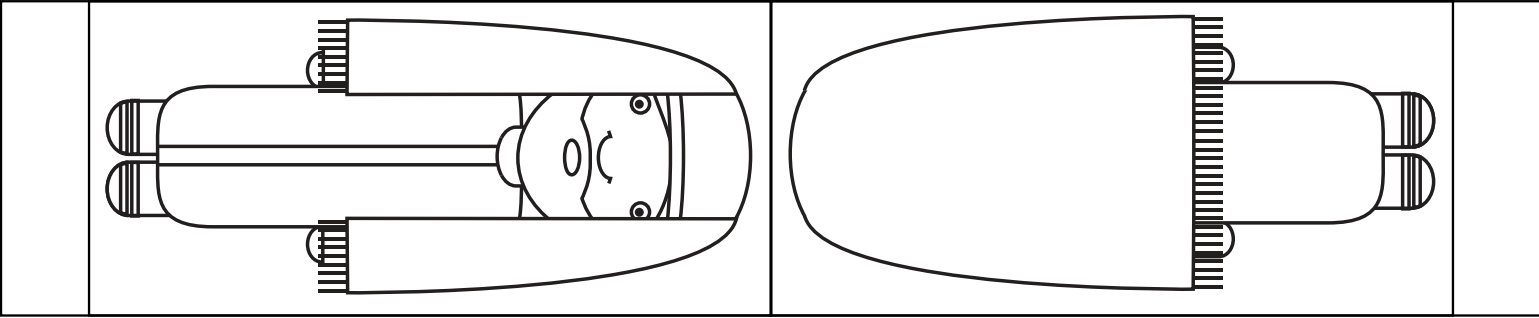
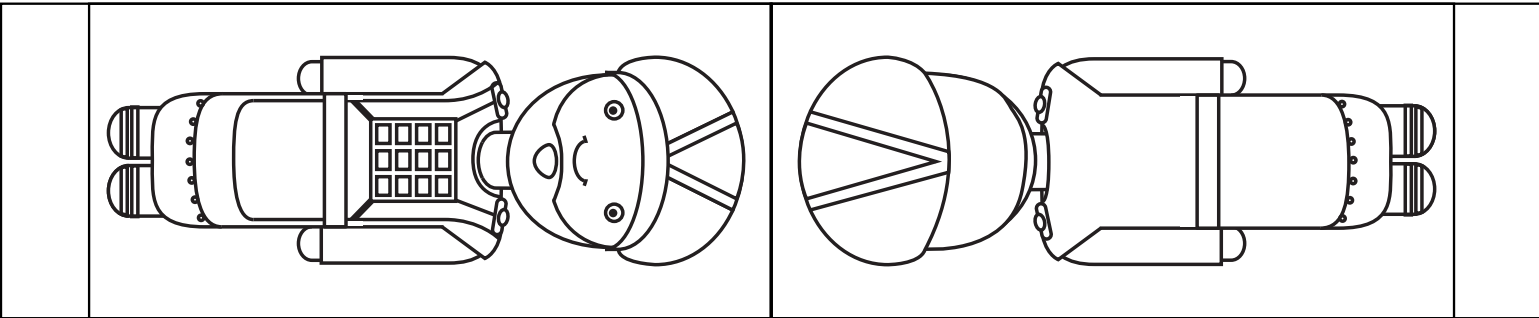

THEY WILL SEE THE SON OF MAN
COMING ON THE CLOUDS OF HEAVEN
WITH POWER AND GREAT GLORY.

MATTHEW 24:30

THEY WILL SEE THE SON OF MAN
COMING ON THE CLOUDS OF HEAVEN
WITH POWER AND GREAT GLORY.

MATTHEW 24:30

THEY WILL SEE THE SON OF MAN
COMING ON THE CLOUDS OF HEAVEN
WITH POWER AND GREAT GLORY.

MATTHEW 24:30

THEY WILL SEE THE SON OF MAN
COMING ON THE CLOUDS OF HEAVEN
WITH POWER AND GREAT GLORY.

MATTHEW 24:30